



2020

Design and Construction Standards Manual



Facilities Department
Effective May 2020



Associate Vice President and
Chief Facilities Officer
Sterrett Center, Suite 112
230 Sterrett Drive
Blacksburg, Virginia 24061

MEMORANDUM

TO: Christopher H. Kiwus, Associate Vice President and Chief Facilities Officer

FROM: Michael Vellines, Design and Construction Standards Official

DATE: May 5, 2020

SUBJECT: Virginia Tech Design and Construction Standards Manual

This memorandum shall serve as a request for review and authorization of the Virginia Tech Design and Construction Standards Manual, May 2020.

Pursuant to the Restructured Higher Education Financial and Administrative Operations Act, § 23.1-1002 et seq. of the Code of Virginia and the resulting Management Agreement Between The Commonwealth of Virginia and Virginia Polytechnic Institute and State University, Virginia Tech has the authority to develop design standards for all university construction projects.

Upon your approval and signature, the Design and Construction Standards Manual will be effective May 5, 2020.

A handwritten signature in blue ink, appearing to read 'C. Kiwus', written over a horizontal line.

Christopher H. Kiwus, PE, PhD
Associate Vice President and Chief Facilities Officer

May 5, 2020
Date

VIRGINIA TECH DESIGN AND CONSTRUCTION STANDARDS MANUAL

The Virginia Tech Design and Construction Standards Manual (DCSM) is intended to provide Architects and Engineers (A/E) with procedural and technical requirements that apply to all design and construction. The DCSM shall be used to develop and submit construction documents and shall be adhered to for all University projects unless specifically waived in accordance with DCSM section 1.3.5. It is the responsibility of the A/E to have read and understood the requirements stated in this document.

This document outlines the design standards for building components and systems for renovation and new construction projects at Virginia Tech. It is to be used in conjunction with the Virginia Tech Construction and Professional Services Manual, latest edition.

The Associate Vice President and Chief Facilities Officer (AVP & CFO) has ultimate authority over the content and execution of the Virginia Tech Design and Construction Standards. Any modifications, additions, or deletions to such Standards shall be under the purview of the AVP & CFO.

Requirements found in the Virginia Uniform Statewide Building Code (VUSBC) and its referenced standards are not repeated in the DCSM. The current adopted version of the VUSBC and its referenced standards are applicable to all Virginia Tech buildings. If unintentional conflicts between the DCSM and other requirements or regulations occur, then the more restrictive requirement for the situation shall apply.

Any questions or suggested changes to the DCSM are welcomed and should be submitted to Mike Vellines, Design and Construction Standards Official, vellines@vt.edu.

TABLE OF CONTENTS

CHAPTER 1 - GENERAL REQUIREMENTS	1
1.1 ACRONYMS AND TERMS	1
1.2 UNIVERSITY DESIGN PRINCIPLES AND MASTER PLANS.....	3
1.3 DESIGN APPROVALS AND PERMITS	8
1.4 PROJECT DESIGN.....	12
1.5 PROJECT SUBMITTAL STANDARDS.....	17
1.6 SITE PLANNING REQUIREMENTS.....	24
1.7 BUILDING PLANNING REQUIREMENTS	24
1.8 COMMISSIONING	43
1.9 PROJECT CLOSE OUT	45
1.10 REPORTING REQUIREMENTS FOR DEB	47
CHAPTER 2 - DOCUMENT AND DRAWING REQUIREMENTS	51
2.1 BASIS OF DESIGN NARRATIVES	51
2.2 COST ESTIMATE STANDARDS.....	64
2.3 GENERAL DRAWING REQUIREMENTS	68
2.4 COMPUTER-AIDED DESIGN (CAD) STANDARDS	86
2.5 SCHEMATIC DESIGN	97
2.6 PRELIMINARY DESIGN.....	100
2.7 WORKING DRAWINGS	109
2.8 DOCUMENT RETENTION REQUIREMENTS	178
CHAPTER 3 - SAFETY AND SECURITY	179
3.1 FALL PROTECTION	179
3.2 SAFETY EQUIPMENT NOT REQUIRED BY CODE.....	181
3.3 EMERGENCY AID SPECIALTIES	182
3.4 EXTERIOR ACCESS	182
3.5 DOORS AND WINDOWS.....	183
3.6 EXTERIOR LIGHTING	183
3.7 ELECTRONIC SAFETY AND SECURITY	184
3.8 COMMUNICATIONS.....	185
3.9 LABORATORY EMERGENCY SAFETY APPLIANCES	191
3.10 FIRE PROTECTION SYSTEMS	192
CHAPTER 4 - SITE DEVELOPMENT	206
4.1 LANDSCAPING.....	206
4.2 PLANTING	209
4.3 TREE CARE PLAN	212
4.4 SIGNAGE	220

4.5	EXTERIOR IMPROVEMENTS.....	220
4.6	STORMWATER DESIGN REQUIREMENTS.....	225
4.7	UTILITIES.....	269
4.8	TRANSPORTATION.....	336
4.9	SITE GRADING.....	339
CHAPTER 5 - BUILDING.....		341
5.1	ENERGY EFFICIENT DESIGN	341
5.2	THERMAL AND MOISTURE PROTECTION DESIGN STANDARDS.....	347
5.3	CONCRETE.....	348
5.4	EXTERIOR ENCLOSURE.....	349
5.5	ROOFING.....	353
5.6	ROOF DRAINAGE, EQUIPMENT, AND ACCESSORIES.....	366
5.7	DOORS AND WINDOWS.....	366
5.8	STRUCTURE.....	374
5.9	DESIGN AND FINISH CRITERIA.....	374
5.10	PARTITIONS.....	375
5.11	INTERIOR SIGNAGE.....	376
5.12	LIGHTING	376
5.13	TOILET, BATH, AND LAUNDRY ACCESSORIES.....	378
5.14	INTERIOR STAIRWAYS	378
5.15	INTERIOR FINISHES.....	378
5.16	FURNISHINGS.....	387
5.17	EQUIPMENT.....	392
5.18	LABORATORY DESIGN	393
CHAPTER 6 - BUILDING SERVICES		404
6.1	BUILDING SERVICES GENERAL	404
6.2	COMMISSIONING REQUIREMENTS	408
6.3	BUILDING AUTOMATION SYSTEM.....	410
6.4	NETWORK COMMUNICATIONS	420
6.5	ELEVATORS.....	503
6.6	PLUMBING.....	507
6.7	HEATING, VENTILATION, AND AIR CONDITIONING	518
6.8	ELECTRICAL SYSTEMS.....	552
6.9	ELECTRONIC MONITORING AND CONTROLS.....	566
CHAPTER 7 - CONSTRUCTION RELATED ACTIVITY.....		569
7.1	PRE-CONSTRUCTION MEETING REQUIREMENTS	569
7.2	PRE-INSTALLATION MEETING/INSPECTION REQUIREMENTS.....	570
7.3	PROGRESS MEETINGS.....	570
7.4	CONSTRUCTION SAFETY	571
7.5	CONSTRUCTION WASTE MANAGEMENT AND DISPOSAL.....	571

7.6	CONSTRUCTION SITE FENCING.....	572
7.7	TEMPORARY FACILITIES, SIGNAGE, AND CONTROLS.....	574
7.8	TEMPORARY PARKING/STAGING AREAS	579
7.9	SITE PREPARATION	580
CHAPTER 8 - INSPECTIONS AND OCCUPANCY		584
8.1	CONSTRUCTION FIELD REPRESENTATIVE INSPECTIONS	584
8.2	UBO SPECIAL INSPECTIONS	589
8.3	UNIVERSITY ROOFING INSPECTION.....	591
8.4	START-UP/ACCEPTANCE OF MECHANICAL AND ELECTRICAL SYSTEMS	595
8.5	SUBSTANTIAL COMPLETION INSPECTIONS.....	595
8.6	FINAL COMPLETION INSPECTION	596
8.7	GUARANTEE PERIOD INSPECTION	597
8.8	BUILDING OCCUPANCY.....	597
8.9	BENEFICIAL OCCUPANCY – NEW BUILDINGS, ADDITIONS AND RENOVATIONS.....	599
8.10	BENEFICIAL OCCUPANCY – RENOVATIONS WITH NO CHANGE OF USE.....	600
APPENDICES		601

CHAPTER 1 - GENERAL REQUIREMENTS

The Virginia Tech Design and Construction Standards Manual (DCSM) and the Virginia Tech Construction and Professional Services Manual (VT CPSM) provide the design standards and procedural requirements for Virginia Tech construction projects. Project specific requirements will be addressed by the Office of University Planning (OUP) and the University Building Official (UBO).

1.1 ACRONYMS AND TERMS

1.1.1 Acronyms

Some of the acronyms used in the DCSM are listed here. Many acronyms are industry-specific and users are advised to consult industry terminology if additional information is needed. Whenever used in the DCSM, including the appendices and the standard forms, the following acronyms have the meanings indicated, which apply to both singular and plural and are not gender-specific.

A/E – Architect/Engineer

AARB – Art and Architecture Review Board

ACM – asbestos-containing material

ADA – The Americans with Disabilities Act of 1990

AIA – American Institute of Architects

AVP & CFO – Associate Vice President and Chief Facilities Officer

BAS – Building Automation System

BOV – Virginia Tech Board of Visitors

CC – Virginia Tech Capital Construction

CFR – Construction Field Representative (or Code of Federal Regulations, if a citation)

CPSM – Commonwealth of Virginia Construction and Professional Services Manual

DCSM – Virginia Tech Design and Construction Standards Manual

DEB – Division of Engineering & Buildings, a division of the Virginia Department of General Services

DEQ – Virginia Department of Environmental Quality

DGS – Virginia Department of General Services

DHR – Virginia Department of Historic Resources

DLI – Virginia Department of Labor and Industry

EHS – Virginia Tech Department of Environmental Health and Safety

EPA – United States Environmental Protection Agency

GSA – General Services Administration, U.S. Federal government agency

LEED – Leadership in Energy and Environmental Design Building Rating System
MRSWA – Montgomery (County) Regional Solid Waste Authority
NI&S – Virginia Tech Network Infrastructure & Services
O&M – Operation and Maintenance
OEM – Office of Emergency Management
OS – Virginia Tech Office of Sustainability
OSHA – Occupational Safety and Health Administration
OUP – Virginia Tech Office of University Planning
RFP – Request for Proposal
SFMO – State Fire Marshal’s Office
SID – Virginia Tech Site and Infrastructure Development
UBO – Virginia Tech University Building Official
USGBC – U.S. Green Building Council
VCC – Virginia Construction Code
VDOT – Virginia Department of Transportation
VOSH – Virginia Occupational Safety and Health Regulations
VSFPC – Virginia Statewide Fire Prevention Code
VT – Virginia Polytechnic Institute and State University (Virginia Tech)
VTAS&S – Virginia Tech Annual Standards and Specifications for Erosion and Sediment Control and Stormwater Management
VT CAC – Virginia Tech Climate Action Commitment
VT CPSM – Virginia Tech Construction and Professional Services Manual
VTES – Virginia Tech Electric Service
VTPD – Virginia Tech Police Department
VT PM – Virginia Tech Project Manager
VUSBC – Virginia Uniform Statewide Building Code

1.1.2 Terms

Some of the terms used in the DCSM are defined here. Many terms are industry-specific and users are advised to consult industry guides and handbooks if additional clarification is needed.

Architect/Engineer (A/E) – The term used to refer to the A/E who provides the architectural and/or engineering services for a Project. The A/E is a separate contractor and is not an agent of the University. This term also includes any associates or consultants employed by the A/E to assist the A/E in providing services.

Capital Project – Project with a total budget of \$3 million or higher or an area of 5,000 square feet or more

Non-Capital Project – Project with a total budget of less than \$3 million and an area of less than 5,000 square feet

Code – Virginia Uniform Statewide Building Code (VUSBC)

University – Virginia Tech

1.2 UNIVERSITY DESIGN PRINCIPLES AND MASTER PLANS

1.2.1 General

It is the University’s intent to maximize the design potential of each campus building project in terms of accommodating the programs to be served, fostering collegiality on the campus, and contributing to the public realm that defines the Virginia Tech campus as a unique place.

In order to achieve the programmatic goals of each project, the design must cost-effectively overlay the specific, user-generated objectives for the project with the University objectives of institutional identity, durability, longevity, flexibility, and adaptability.

In order to foster collegiality, each project must create environments, which encourage interaction and discourse among students, faculty and staff. This potential shall be recognized in the development of interior and exterior environments.

While a major responsibility of programmatic accommodation is to the development of the “insides” of the project, every project also has a responsibility to the greater whole of the campus. This responsibility to the public realm recognizes the importance of the architectural and planning traditions at Virginia Tech and strives to contribute to the further development of the campus as a highly imaginable, unique, and inspiring place.

To achieve these goals, it is incumbent upon the project design team to invest in an understanding not only of immediate program goals but also of the history of planning and architecture on the campus, of the goals and objectives of the current campus master plan, and particularly of the immediate context (precinct and site) for the project.

Further elaboration of many of these points can be found in the OUP Campus Master Plan on the web. Where color selections are provided, provide three options from which the OUP may choose.

1.2.2 Master Plans

Contracted firms will adhere to the latest versions of the principles, guidelines, and Master Plans.

- Beyond Boundaries Campus Master Plan
- Campus Design Principles
- Parking and Transportation Master Plan
- Bike Parking Master Plan
- Universal Design Principles Checklist
- Virginia Tech Student Experience: Virginia Tech's Next 20 Years

1.2.3 Accessible Design

It is the University's policy to create learning and working environments that foster participation by all persons who visit, attend, and work for Virginia Tech. Virginia Tech complies with the ADA Standards for Accessible Design, latest edition, for all new construction and renovations.

In addition to the ADA Standards, Virginia Tech has these requirements:

1. All doors shall have a minimum width of 36 inches (see DCSM section 5.7).
2. Automatic operators (see DCSM sections 5.7.1, 5.7.3.1, and 5.7.7) shall be provided for:
 - a. At least a single door along an accessible route
 - b. Main building entrances
 - c. Access into all restrooms
 - d. Access into a minimum of 50% of all classrooms, with a minimum of one door in all classrooms with two doors, and with a preference for classrooms with higher occupancies
3. Accessible routes from main pedestrian areas shall be clearly marked (e.g., the drillfield). Accessible routes shall be shown on submitted plans (see DCSM sections 2.3.1.1.3 and 2.3.1.1.9).
4. Classroom hallway widths shall be in accordance with DCSM section 1.7.2.2.1.
5. Knee spaces for accessible seating at tables or counters shall be at least 30-inches high, 32-inches wide, and 19-inches deep.
6. Auto-flush devices shall be installed on all accessible water closets (see DCSM section 6.6.7.11).
7. Where emergency power is provided in the building, at least one elevator shall be provided with emergency power to allow operation during a power outage (see DCSM section 6.5).

Accessibility shall be included in the initial planning of all new facilities, not as an afterthought in a code review of a design that is complete. Accessible Design standards cannot be removed or diminished as a result of Value Engineering.

Where feasible, new construction and renovation projects should provide additional accessible design elements. Examples include:

1. Add an additional 6 inches in width and length in accessible restroom stalls.
2. Increase turning radius to 6 feet in accessible restrooms.
3. Add an additional 6 inches to the overall width for accessible ramps.
4. Maintain a minimum of 60 inches for the clear width at a 180 degree turn for an accessible route (see Figure 403.5.2 in the 2010 ADA Standards).

Coordinate with OUP for project specific goals.

1.2.4 Universal Design

Universal design that incorporates equal access for all persons shall be a primary planning criterion at Virginia Tech. Addressing the diverse needs of the campus population will require a broad framework for evaluating future building, interior, and site design projects. In new construction, there shall be integrated access for persons with disabilities and the general population.

At the beginning of the planning process, the A/E is encouraged to evaluate exterior and interior circulation conditions and propose innovations in accessible routes, spaces, and amenities to create a more welcoming and inclusive campus. The A/E shall develop a design that strives to minimize hazards, eliminate auditory and visual barriers, and provide the appropriate space for approach, reach, manipulation, and use of campus elements regardless of the user's body size, posture, or mobility.

Where feasible, new construction and renovation projects should provide additional universal design elements. Examples include:

1. Make the main entrance to the building accessible.
2. Add additional space for maneuverability of larger wheelchairs.
3. Increase quantity of accessible restrooms/stalls.
4. Provide additional grab bars in accessible restrooms.
5. Provide accessible parking near accessible entrances with a clearly marked accessible route.
6. Provide additional wheelchair locations in assembly areas.
7. Provide additional wheelchair seating at tables and counters.

Coordinate with OUP for project specific goals.

1.2.5 Sustainability

Per the latest revision of the Presidential Policy Memorandum No. 262, the Virginia Tech Climate Action Commitment (VT CAC), Virginia Tech will be a leader in campus sustainability and programs to achieve sustainability goals will be represented in the University's Strategic Plan. Innovations in construction and building design have raised the benchmark for certification standards for buildings since 2013. The VT Facilities Department will strive to incorporate a maximum amount of sustainability improvements to honor the VT CAC to the limits of affordability for each design project.

The University is committed to the principles of energy conservation. All designs shall strive to maximize energy efficiency, and comply with the energy conservation requirements contained in these standards and Campus Energy, Water, and Waste Reduction Policy – No. 5505.

1.2.5.1 Sustainable Design

In order to incorporate sustainable design solutions in new construction and renovation projects, Virginia Tech has joined the U.S. Green Building Council (USGBC) and fully supports the principles of the LEED (Leadership in Energy and Environmental Design) Building Rating System. The pursuit of high performance green buildings that are energy efficient and environmentally sensitive will help to lower operating and energy costs, improve employee productivity, promote improved learning, and enhance the health, and well-being of the students, faculty and staff at Virginia Tech. All projects shall address sustainability as it relates to site issues, water, energy efficiency, materials and resources, and indoor air quality in accordance with the VT CAC.

In the early stages of design, the A/E shall strive to meet or exceed the minimum number of points needed for LEED certification under the rating system appropriate for the project in accordance with the VT CAC. The A/E shall determine the most cost effective means of achieving these points, and shall take full credit for points achieved through compliance with other University standards that address sustainability issues, such as building commissioning. The A/E shall submit for the University's review and approval a LEED Project Checklist, identifying the specific measures proposed to be incorporated into the project to achieve the target number of points. The A/E should consider the ParkSmart certification for projects involving parking garages.

1.2.5.2 Waste Management

Virginia Tech is a jurisdictional member of the Montgomery Regional Solid Waste Authority. All members transitioned to single stream recycling effective July 1, 2015.

To achieve the recycle rate goal stated in the VT CAC, Virginia Tech requires an appropriate number of waste stations, both outside and inside of our facilities. All recycling containers for new construction and major renovations must be able to accommodate single stream recycling.

1. Outside the Building:
 - a. The design of the waste management serving area shall provide a concrete slab 26 feet wide by 14 feet deep to accommodate an 8 cubic yard single stream recycling container and another 8 cubic yard trash container placed side-by-side. It must provide an access route to accommodate an AASHTO WB-40 Design Vehicle. In order to accommodate this design vehicle during loading and unloading operations, a concrete road surface shall be placed along the entire 26-foot width of the concrete slab and extended outward and perpendicular a distance of 8 feet.
 - b. Outdoor waste stations for personal use should consist of an appropriate number of pairs of containers placed side-by-side with one designated and labeled for “single stream recycling” and the other designated and labeled for “trash.” The containers must conform to our design standards for outdoor furnishings.
2. Inside the building:
 - a. Indoor waste stations shall consist of an appropriate number of pairs of non-combustible collection containers placed side-by-side with one designated and labeled for “single stream recycling” and the other designated and labeled for “trash.”
 - b. Ideally containers will be recessed into the interior walls of the building so as to not protrude into the hallway space. If that is not possible the containers shall be placed on the floor and secured to the building structure to meet fire code.
 - c. The quantity and design for indoor waste stations in residential buildings will vary. Coordinate with Student Affairs during the initial design.

1.3 DESIGN APPROVALS AND PERMITS

The A/E of record shall supply all materials and data necessary for required reviews by University and state boards and departments. The OUP shall be consulted on any requirements.

All projects requiring approval, whether by the Board of Visitors (BOV) or Virginia Art and Architecture Review Board (AARB), shall provide:

1. Project Data Sheet
2. Written Narrative
3. Rendered Site Plan: one with and one without labels
4. Rendered Planting Plan: one with and one without labels
5. Planting Schedule
6. Color-coded Rendered Floorplans with Legend: one set showing furniture with no labels, one set not showing furniture or labels, and one set showing both furniture and labels
7. Exterior Perspective Renderings (including entourage): all cardinal elevations and major project elements – rendered elevations may be substituted for projects that are small in scale by permission from the OUP
8. Illustrative Images: building materials and plantings
9. Material Samples
10. Cost Estimates: reflective of the designs shown in these materials

Projects shall not be eligible for a review if cost estimates do not show the designs depicted as within-budget. No A/E logos shall be included on submission materials. The OUP shall be consulted for any additional examples of presentation materials.

1.3.1 Virginia Art and Architecture Review Board

1. All projects involving the new construction of a facility, the removal, remodeling of, or addition to an existing facility, or the attachment/placement of any appurtenant structures to an existing facility must receive design approval by the AARB. This requirement does not include ordinary maintenance and repair.
 - a. Submittals to the AARB are required at the schematic and/or preliminary design stages. Consult with OUP for project specific requirements.
 - b. All Capital Projects and all major renovations that require AARB approval shall budget for two presentations by the A/E of record to the AARB.
2. All demolitions of structures with state building numbers requires approval by the AARB.

3. All works of art to be placed in, upon, or to extend over any University property for a period of more than two years must receive approval by the AARB.

1.3.2 Board of Visitors

All Capital Projects and demolitions of structures with state building numbers requires approval by the BOV. Regular BOV meetings are held quarterly, typically in the months of March, June, August, and November. Documents are typically required to be submitted a minimum of two months prior to the meeting. Coordinate with the Virginia Tech Project Manager (VT PM) and OUP regarding specific meeting dates and submittal deadline dates.

1.3.3 Virginia Department of Historic Resources

All demolitions of structures with state building numbers requires approval by the Virginia Department of Historic Resources (DHR).

1.3.4 Environmental Impact Reports

The University will procure and submit an Environmental Impact Report (EIR) when a project or real property acquisition has a total project cost of \$500,000 or more as defined in the *Code of Virginia* § 10.1-1188. Regulatory authority is assigned to the Virginia Department of Environmental Quality (DEQ) in *Code of Virginia* § 10.1-1191. Submission requirements can be found at the Virginia DEQ website. An EIR may not be required by DEQ for interior renovations and work covered by a previous EIR. However, the University will submit its request to DEQ citing the nature of the work and justification for excluding the project from the requirements for an EIR. DEQ will make a determination on the validity of the request and provide a written response on its findings.

The OUP must be provided all EIRs prior to issuance to the DEQ to allow for coordination with the DHR.

1.3.5 Design Standard Waiver Request Requirements

The DCSM shall be used on all University projects. Any design standard waiver requests shall come from the VT PM. The VT PM should have preliminary discussions with the Director of Facilities Engineering and Assessment before submitting the design waiver. The design waiver request shall be submitted through the Assistant Vice President for Capital Construction for capital projects or the Assistant Vice President for Facilities Operations for renovation projects, through the Director of Facilities Engineering and Assessment,

through the Design and Construction Standards Official, to the Associate Vice President and Chief Facilities Officer (AVP & CFO) for final approval.

The waiver request shall contain the standard for which the applicant is requesting a waiver, the justification for the waiver, and any supporting documentation as attachments. In addition to the signed copy, all design waivers shall be submitted electronically to the Design and Construction Standards Official. See the VT Design Standard Forms Library for the VT Design Standard Waiver Request form.

Approved waiver requests shall be included with 100% drawings for permit requests prior to plan reviews to avoid comments being made on items for which a waiver has been approved. Note that building permits will not be issued for projects with unresolved waiver requests.

1.3.6 Land Disturbance Permits

Virginia Tech's Annual Standards and Specifications for Erosion and Sediment Control and Stormwater Management (VTAS&S) program is managed by Virginia Tech Site and Infrastructure Development (SID). As part of that program, SID issues Land Disturbance Permits for all regulated projects on University-owned property. See the VTAS&S for more information and for permit requirements.

The Virginia Tech Land Disturbance Permit does not replace the requirement for the Contractor to submit for a DEQ Construction General Permit for projects with one acre or more of total land disturbance. Information for the Construction General Permit can be found on the DEQ website.

1.3.7 Building Permits

The UBO is the authority for code and standard compliance for all construction activities on University-owned property and/or buildings. The UBO is responsible for the review of the working drawings/bid documents to assure conformance with the applicable codes and standards established. The A/E shall design to all applicable codes and standards regardless of the UBO review. A building permit shall be issued by the UBO and is required for work in accordance with the VUSBC.

The VT PM shall submit an Application for Building Permit (HECO-17) to the UBO. Any required permits for projects shall be obtained through the UBO.

The construction documents submitted for Building Permit shall have sufficient information, sizes, dimensions, details, material descriptions, loads and load

capacities, plans, sections, elevations and details for the UBO to determine that the proposed work conforms to the requirements of the Building Code and applicable standards and policies. For most projects, this submittal will be plans and specifications. For repairs, remodels and minor improvements, it may be plans and specs or sketches with dimensions or even a narrative of the work to be done. In any case, the documentation must describe what is to be done and show that the work will conform to the requirements of the building code and applicable standards and policies.

1.3.7.1 Partial Building Permits

When Construction Management at Risk and Design-Build procedures are used, the opportunity may exist for construction to start before the complete building design has been finalized. Ensure all required Virginia Department of General Services (DGS) forms are submitted prior to issuance of partial building permits.

Partial building permits can be issued for early construction. If partial permitting is used, a separate building permit submittal shall be made for each portion of the work. Subsequent building permits shall supersede any previously issued partial permits with the full building permit governing the project once that permit is issued. The manner in which the project is separated into partial permits shall be subject to the approval of the UBO.

The minimum required submittal is the complete working drawing submittal as described in DCSM section 2.7.

1.3.7.2 Demolition Permits

The VT PM shall submit an application for Demolition Permit, HECO-17.1, to the UBO. Use the current edition of the HECO-17.1 on the [VT Facilities Forms](#) web page. The following attachments are required with the submission of the HECO-17.1:

1. AARB Demolition Approval – Copies of the front page of the Meeting Minutes with the date of the meeting and relevant page(s) in the Minutes that address demolition.
2. DHR Demolition Approval – Copy of the approval letter/memo from DHR.
3. Photographs of exterior and interior of building.
4. Other information as deemed appropriate by the University to support the application.
5. Clarifications of information for the HECO-17.1 form.

6. Completed surveys of hazardous materials (asbestos and lead paint). If hazardous materials were found and not previously abated, Abatement Designs must be complete and incorporated as part of the Demolition Contract.
7. Completed Date of Release by Utilities with Release dates noted (no future dates accepted). The only exception allowed is when the Releases are required as part of the Contractor's work in the Demolition Contract, which shall be noted on the HECO-17.1.

1.3.7.3 Temporary Facilities (Other than Tents and Stages)

Prior to submitting a requisition to the University Procurement Office (where purchase is involved) or before finalizing any contractual arrangements for lease of a temporary facility, the University must assure that the item being leased or purchased will meet the requirements of the VUSBC. Before the item is delivered to the site, the University should submit plans of the structure to UBO for issuance of a building permit and ensure the structure is accessible to the disabled. Plans submitted to UBO shall include site location plan, proper anchorage, tie down and utilities for the structure.

Prior to occupancy, the VT PM shall apply to the UBO for a Certificate of Occupancy for the facility. Application shall be made in accordance with the building permit guidelines in the DCSM.

1.4 PROJECT DESIGN

1.4.1 Pre-Design Conference

The VT PM shall arrange for a pre-design conference for all Capital Projects and appropriate Non-Capital Projects. Participants should include University representatives and the A/E's Project Manager and the responsible designer in each discipline (architect, civil, structural, mechanical, electrical and others if needed). The purpose of the pre-design conference is to clarify the procedures, needs and requirements for the particular project.

1.4.2 Value Engineering

Capital Projects with a project cost greater than \$5 million shall have a 40-hour Value Engineering (VE) Study conducted on the design according to the *Code of Virginia* § 2.2-1133. The study shall be conducted by a qualified VE Team concurrent with the preliminary (40%) design review utilizing the five-step job plan as recognized by the Society of American Value Engineers (SAVE). A

presentation of the study results shall be made to the University. The University shall be provided a summary of cost savings that have been incorporated into the design as well as potential cost savings that were considered but not incorporated.

1.4.2.1 Scope of VE Study

The VE Study shall be made by a multi-discipline team of five VE qualified professionals. The VE report shall encompass the recommendations of the VE study group and include detailed cost estimates, life cycle analysis and sketches, as necessary. VE services shall be performed in a timely manner concurrently with the normal preliminary design review.

1.4.2.2 Qualifications of VE Team

The VE proposer/consultant shall provide one team consisting of a Certified Value Specialist Team Leader and at least one licensed architect and one licensed professional engineer from each discipline which have significant work on the project, separate and completely independent from the Project A/E and its consultant firms.

The VE Study shall be coordinated, supervised and led by a person having Certified Value Specialist (CVS) credentials that qualify him/her to perform such services. The CVS shall be certified by SAVE and shall have had a minimum of eight years combined college education and practical on-the-job VE experience. Practical experience is considered to have been gained by being actively engaged as a consultant in VE activities.

Members of the team shall be registered architects and professional engineers licensed in the Commonwealth of Virginia. Team members shall be knowledgeable of the design and operational requirements and characteristics of the systems applicable to their discipline and the type of facility being studied.

1.4.2.3 Information Supplied to the VE Team

Prior to commencing the VE study, the A/E will forward the following information to the VE Team in the format requested and with the number of copies requested for each:

1. 35% drawings
2. Outline Specifications and Systems Checklists
3. Detailed Cost Estimate
4. Basis of design

5. Design Calculations (Structural, Mechanical, Electrical)
6. Boring logs and soil reports
7. Scope of Project/Program requirements

1.4.2.4 VE Report Requirements

The results of the VE study performed on the project shall be documented as follows:

1. Contents page.
2. Brief description of total project and project requirements with a copy of the University's program requirements.
3. Brief summary of VE recommendations.
4. One site plan, floor plan and elevation on 8½" × 11" or fold out.
5. Summary sheet (only) of 35% cost estimate.
6. VE cost model of project.
7. Each VE recommendation shall be described Before and After VE and shall be accompanied with a detailed cost estimate of savings, life cycle cost analysis and sketches as necessary.
8. Complete Six Step Job Plan (workshops) of all work shall be submitted as appendices for reference.

All reports shall be systematically assembled and must be short and concise, yet informative enough for decision making. VE Reports shall be prepared and submitted on 8½" × 11" bond paper and bound under hardback cover appropriately identified. Sketches may be 8½" × 11" or fold-out. Pages must be sequentially numbered in the lower right hand corner to facilitate assembly. Tabs should be used for quick reference of important sections of report.

1.4.2.5 Oral Presentation

At the completion of the Value Engineering Study, the VE team leader and members as appropriate shall make an oral presentation to the University and the Design A/E of the items recommended to be implemented on the project.

1.4.2.6 A/E Participation

The design A/E responsibilities include the following:

1. Present an overview of the project criteria and development to the value engineering team.
2. Provide comments on the VE study report to the University within 14 days of receipt of the report.

3. Participate in joint 35% review/VE resolution meeting at the University if required.
4. Submit a final report within 14 calendar days of the resolution meeting to the University.
5. Implement all finally accepted VE recommendations into the project design.

1.4.2.7 Criteria Challenge

In the package of documentation which the design A/E prepares for the Value Engineering Consultant, the design A/E may include a Criteria Challenge Package to question specific project design criteria, instructions and/or user requirements and to identify alternate items or procedures that might satisfy the required functions at a lower life cycle cost.

Each challenge must include Code references, a life cycle analysis supported by recent research and testing, and any calculations that are necessary to support the challenge. A brief narrative describing the advantages, disadvantages and magnitude of potential savings shall be included as well.

The Criteria Challenge Package with the documentation provided to the Value Engineering Consultant shall be marked VALUE ENGINEERING and submitted with the Preliminary Submittal to the University.

1.4.2.8 A/E Action on VE Study

The following clarifies the specific submittals and approval procedures required for the VE Study responses and proposed action:

1. Both the University and the A/E shall review and evaluate the Value Engineering recommendations. Not all VE recommendations are automatically appropriate for inclusion in state projects.
2. The A/E shall provide a written comment and/or evaluation of each VE recommendation to the University along with the A/E's recommendation to accept, to reject, or to accept with modifications each VE recommendation. The A/E shall also provide its responses to the University's preliminary review comments.
3. The A/E shall provide justification for rejection of, or modification to, any VE recommendation.
4. The A/E shall prepare a Summary of Value Engineering Recommendations and indicate its recommended disposition of each item. The A/E's completed electronic summary sheet shall accompany the detailed responses sent to the University.

5. The University shall review the A/E's evaluation and recommendations on the VE Study and the A/E's responses to the University review comments. The University shall indicate its proposed action (acceptance, rejection, or acceptance as modified) on the summary sheet.
6. If any proposed action deviates from the requirements of the VUSBC or the DCSM, the VT PM shall submit a request for code modification or waiver of the DCSM requirements for each item along with appropriate justification.
7. Upon resolution of the VE Study and comment responses, the HECO-5 will be approved and authorization given to prepare working drawings.

1.4.3 Life Cycle Costs and Energy Analysis

The Building Life Cycle Cost Summary worksheet (form DGS-30-228) can be used to calculate costs.

Costs are to be computed over a 30 year period, except as noted below.

Building Envelope Studies	30 years
Central Heating/Cooling Plants	30 years
Building HVAC Systems	20 years
Fuel Selection Studies	20 years

Costs for each alternative must be shown on the Life Cycle Cost Worksheet. Include appropriate backup to support the summary figures shown on the worksheet (i.e., indicate how the various costs were calculated and note the basis or source of the cost data).

Average service lives of mechanical equipment shall be based upon the Average Service Life shown in the ASHRAE Applications Handbook.

The type of system and the energy source shall be clearly noted on the Life Cycle Cost Worksheet.

The supporting backup shall clearly show the various fuel/energy rates (\$/gallon, \$/kWh, etc.) and the data source for each.

1.4.3.1 Instructions for Completing Worksheets

1. Use a new Worksheet for each alternative.
2. Complete all general information at the top of the Worksheet.
3. Fill in columns "a" thru "f" for each year. Use escalated costs. On the Worksheet, specify the annual escalation rate used for each cost category. In the supporting documentation, identify the source/basis for the chosen escalation rates.

4. Sum Columns “a” thru “e” for each year; subtract Salvage Value (Column “f”) and place results in Column “g.”
5. Multiply the Column “g” figures by the corresponding discount factor in Column “h” and place results in Column “i.”
6. Sum Column “i” and place results in the box at the bottom of the Worksheet.

1.5 PROJECT SUBMITTAL STANDARDS

1.5.1 Project Submission Requirements

The A/E shall provide adequate copies of plans, specifications, cost estimates, and other applicable data to the VT PM. An electronic version of all documents is required with each submittal. The VT PM will distribute appropriate documents (both electronic and hard copy) to the UBO and Site and Infrastructure Development (SID) for permit reviews and to Engineering Operations and OUP for the University’s use and review. SID submittal is required only when land disturbance is involved. See the VTAS&S for more information. Specific projects may have different requirements; coordinate with the VT PM.

Minimum requirements for hard copy documents submitted by the A/E to the VT PM:

1. UBO – one half-size copy of the plans and any proposed DCSM waivers
2. SID – one full-size copy of civil and landscape plans and two bound copies of the erosion and sediment control (ESC) and stormwater narratives (as applicable)
3. OUP and Engineering Operations – one full-size copy and one half-size copy of the plans and technical specifications

1.5.2 Capital Project Initiation

The University will be authorized to initiate the design of a Capital construction project upon receipt of an approved HECO-2. The University shall notify (using the form CO-2A) the chief administrative officer of the county, city, or town in which the University intends to undertake the Capital Project. The CO-2A shall be submitted at the initiation of the EIR.

1.5.2.1 Preplanning Studies

Preplanning studies are authorized to allow the University to develop a more detailed definition of cost and scope for a future Capital Budget Request. A Preplanning study may include the following elements, as appropriate:

1. Statement of program definition including functional space requirements, estimates of gross and net square footage, and functional adjacency requirements;
2. Analysis of program execution options, including review of new construction versus renovation alternatives, necessary phasing or sequencing of the project, and
3. Coordination with other ongoing or proposed capital projects;
4. Site analysis, including options considered and, for the site chosen, any specific issues related to topography, utilities, or environment;
5. Condition assessment of systems or infrastructure elements such as roofs, plumbing, or electrical to determine the extent of repair or replacement work that needs to be done.
6. Presentation, including site plan, conceptual floor plans and elevations, and conceptual exterior;
7. Identification of any VUSBC compliance or permit requirements unique to the project;
8. Cost estimate for the project to include total cost of the project, construction cost for the project, total cost per square foot, construction cost per square foot, costing methodology, and identification of any factors unique to the project that may affect overall project cost.

1.5.2.2 Construction Projects

The 3-digit University code and the five digit project code assigned to the project in the Appropriation Act shall be the basic project identifier for the life of the project. A project that will be accomplished by separate contracts at multiple locations or acquisitions at multiple locations; or a single project to be accomplished through two or more construction contracts, shall assign a 3-digit sub-project code for each undertaking.

1.5.3 Non-Capital Outlay Projects

Projects shall be designed by and sealed, signed and dated by a Virginia licensed A/E. The UBO may waive this requirement based on size and scope. Coordinate with the UBO. Working drawings ready for bidding and the appropriate information for the HECO-17 shall be submitted to the UBO for review and issuance of a Building Permit. Refer to DCSM section 1.3.7 for further information.

The following CO forms shall be used for execution of the construction contract:

CO-9	Contract Between Owner and Contractor
CO-9.1	Notice of Award
CO-9.2	Notice to Proceed
CO-10	Standard Performance Bond
CO-10.1	Standard Labor and Material Payment Bond
CO-10.2	Standard Bid Bond
CO-11	Contract Change Order
CO-12	Schedule of Values and Certificate for Payment
CO-13	Affidavit of Payment of Claims
HECO-13.1A	Certificate of Substantial Completion by Architect/Engineer
HECO-13.2A	Certificate of Substantial Completion by Contractor

1.5.4 Specification Standards

Specifications shall be in sufficient detail to describe without ambiguity, all materials, equipment, supplies and other pertinent information. Required tests and guarantees shall be indicated in the specifications. The specific elements of the project manual may vary depending on project size. Coordinate specific requirements with the VT PM.

1.5.4.1 Project Manual/Specifications Arrangement

Specifications shall be on 8½" by 11" sheets with bid sets preferably printed on both sides of the sheet. Font size shall be suitable for scanning and shall not be smaller than 10-point font size. The table of contents pages shall be dated with the same date as the drawings and shall be sealed and signed.

The Project Manual shall include:

- Table of Contents
- Notice of Invitation to Bid (refer to sample format in DGS-30-256)
- Instructions to Bidders (CO-7A)
- Prebid Question Form (DGS-30-272)
- Bid Form (refer to format in DGS-30-220)
- Standard Bid Bond Form (CO-10.2)
- Commonwealth of Virginia General Conditions of the Construction Contract (CO-7, CO-7CM, CO-7DB)
- Supplemental General Conditions, if applicable (refer to samples in DGS-30-376)
- Contract Between Owner and Contractor (CO-9)
- Workers Compensation Insurance Certificate (CO-9A)
- Standard Performance Bond (CO-10)
- Standard Labor and Material Payment Bond (CO-10.1)
- Change Order blank (CO-11)

- Change Order Estimate (General Contractor) (GC-1)
- Change Order Estimate (Subcontractor) (SC-1)
- Change Order Estimate (Sub-subcontractor) (SS-1)
- Schedule of Values and Certificate for Payment (CO-12)
- Affidavit of Payment of Claims (CO-13)
- Certificate of Completion by Architect/Engineer (HECO-13.1)
- Certificate of Partial or Substantial Completion by A/E (HECO-13.1A)
- Final Report of Structural and Special Inspections (HECO-13.1B)
- Certificate of Completion by Contractor (HECO-13.2)
- Certificate of Partial or Substantial Completion by Contractor (HECO-13.2A)
- List of Drawings
- Submittal Register Format (refer to sample in DGS-30-364)
- Special Inspections List (CO-6A, CO-6B, CO-6D, CO-6E, CO-6F)
- Special Requirements for Low Slope Roofing Membranes (DGS-30-326)
- Division 1 – General Requirements, Special Conditions, etc.
- Technical Specifications
 - Technical Specification Sections shall be numbered with appropriate section numbers corresponding to an industry-standard specifications format, such as one of the two CSI Masterformat numbering systems. The numbering system shall be consistent within the entire submittal.
 - Technical Sections should, where possible, be subdivided into the Part I – General, Part II – Products, Part III – Execution format.
- Appendices containing Soils Report, Asbestos Inspection Survey Report, Lead Inspection Survey Report and/or other information pertinent to the project but not a part of the Work. Such material should be noted as “INFORMATION ONLY” for use by the Contractor.

1.5.4.2 Types of Specifications

There are three types of specifications used on state projects:

1.5.4.2.1 Non-Proprietary and Performance Specifications

This is the preferred method of specifying materials, equipment and systems. A non-proprietary specification shall be written either as a generic performance specification (preferred) or as a specification naming a minimum of three manufacturers with model or series numbers.

A generic performance specification must be written to describe the required characteristics, performance standards, capacities, quality, size

or dimensions, etc., of the item or system. A minimum of three manufacturers must be able to meet all requirements shown in the specification. The specification shall not be contrived to exclude any of the three manufacturers or to benefit any one manufacturer over any of the other manufacturers. The performance specification shall not name manufacturers or brand name products.

A non-proprietary manufacturer/model number type specification must list at least three manufacturers with their respective model numbers. Each of the listed manufacturers/model numbers must have been determined by the A/E to meet the specifications and be acceptable. If a named manufacturer pre-packages or pre-assembles its item or system, the model number shall be specified. If the named manufacturer(s) custom builds the item or system, naming of model numbers is not required.

The manufacturer/model specification must describe the required characteristics, performance standards and capacities which will be used to determine equal products as allowed by section 26 of the General Conditions of the Construction Contract, form CO-7. Do not specify extraneous characteristics that do not relate to the product's performance or suitability for the project. If only two acceptable manufacturers can be found and documented by model number but other equal products are acceptable if found by the bidder, the A/E may request permission from the AVP & CFO, to list only those two manufacturers but consider equals if proposed by the Contractor.

1.5.4.2.2 Proprietary Specifications

A specification is proprietary if it specifies a product/requirements which only one manufacturer can meet but the product is available from multiple vendors or sources. Although a proprietary specification should be avoided because it restricts competition, circumstances such as space limitations, mandatory performance standards, compatibility with an existing system, etc., may leave no other reasonable choice.

Proprietary specifications may be used when approved by the AVP & CFO. Refer to section 6.0.3.1 in the VT CPSM for Proprietary Procurement Procedures.

1.5.4.2.3 Sole Source Specifications

A specification is sole source when it names only one manufacturer or product to the exclusion of others, or when it is contrived so that only one manufacturer, product, or supplier can satisfy the specification. Because it eliminates all competition, it can be used only in the most exceptional circumstances and under the strictest conditions. A product, piece of equipment or service which is available only thru an area franchised vendor is also considered to be a Sole Source item.

Sole source procurement may be used when approved by the AVP & CFO. Refer to section 6.0.3.3 in the VT CPSM for Sole Source Procurement Procedures.

1.5.4.3 Hardware Specifications and Schedules

Hardware specifications and schedules may be written to specify the applicable Builders Hardware Manufacturer's Association (BHMA)/American National Standards Institute (ANSI) standards and designations or the specifications and schedules may be written by specifying three manufacturers and model numbers for each item. In either case the specifications must give sufficient information of the type, size, function, finish, etc., for the vendor to know what is required and for the A/E to evaluate the submittals.

1.5.4.4 Approvals, Equals, and Substitutes

Deviations from design product specifications should be submitted for approval via an RFI to the VT PM.

1.5.4.4.1 Brand Names

Unless otherwise stated in the specifications, the name of a certain brand, make or manufacturer denotes the characteristics, quality, workmanship, economy of operation and suitability for the intended purpose of the article desired, but does not restrict bidders to the specific brand, make, or manufacturer. The brand names are shown to convey to the Contractor the general style, type, character and quality of article specified. If brand names are listed in the specifications, specify a minimum of three brands with model numbers.

1.5.4.4.2 Equal Materials, Equipment or Assemblies

Any brand, make or manufacturer of a product, assembly or equipment which in the opinion of the A/E is the equal of that specified, considering

quality, capabilities, workmanship, configuration, economy of operation, useful life, compatibility with design of the work, and suitability for the intended purpose, will be accepted unless rejected by the University as not being equal.

1.5.4.4.3 Substitute Materials, Equipment or Assemblies

The General Conditions permit the Contractor to propose a substitute or alternate material, product, equipment, or assembly which deviates from the requirements of the Contract Documents but which the Contractor deems will perform the same function and have equal capabilities, service life, economy of operations, and suitability for the intended purpose. Examples of substitutes or alternates include proposing to substitute “precast concrete” for “cast-in-place concrete” floors or to substitute “precast concrete panels” for “masonry” walls. The Contractor’s proposal must include any cost differentials proposed.

The University would have the A/E provide an initial evaluation of such proposed substitutes to include a recommendation on acceptability and indicate the A/E’s redesign fee to incorporate the substitution in the design. If the proposed substitute is acceptable to the University, a Change Order would be proposed to the Contractor to accept the substitute and to deduct the cost of the A/E redesign fee and the proposed cost savings from the Contractor’s Contract amount. The University will have the right to limit or reject substitutions at its sole discretion.

1.5.5 Plans, Sections and Details of Equipment or Systems

1.5.5.1 Design Intent

The drawings shall have sufficient plans, sections and details to generally indicate the intended equipment or system configuration in the space. Recognizing that it is often necessary to use some piece of equipment as a basis for designing, dimensioning and detailing, the drawings (but not the specifications) may be noted to indicate that the A/E has designed or detailed around a particular brand of equipment. In doing so, the A/E shall ensure that there is adequate space, capacity, etc., available to accommodate the other brands indicated in the specifications.

1.5.5.2 Basis of Design

Where a particular manufacturer's product is indicated as the basis for design and detail, the following statement shall be placed on the drawing with appropriate noting/references:

"The design [detail] [section] shown is based on [manufacturer and model] equipment and is intended only to show the general size, configuration, location, connections and support for equipment or systems specified with relation to the other building systems. See specification section [xxx] for technical requirements pertaining to the equipment."

1.6 SITE PLANNING REQUIREMENTS

All projects on University-owned property are required to comply with the DEQ-approved Virginia Tech Annual Standards and Specifications for Erosion and Sediment Control and Stormwater Management (VTAS&S) in addition to the DCSM. Consideration of stormwater management requirements shall be made early in the project planning and design process. Coordinate project specific requirements with the VT Erosion and Sediment Control and Stormwater Management Program Administrator.

1.6.1 State Building Construction in Floodplains

New construction of state-owned buildings within the 500-year floodplain shall be in accordance with Executive Order 45.

1.6.2 SID Inspections

SID shall complete erosion and sediment control and stormwater management (ESC/SWM) inspections in accordance with the VTAS&S. Refer to the VTAS&S for specific SID inspection requirements.

ESC/SWM Inspections shall be made by DEQ certified inspectors. For ESC only inspections, inspector shall be certified as an ESC Inspector through the DEQ. For stormwater management (SWM) inspections, inspector shall be certified as a SWM Inspection through the DEQ.

1.7 BUILDING PLANNING REQUIREMENTS

1.7.1 Mock-Up Requirements

Provide a detail of a mock-up wall section that is representative of all building materials proposed for exterior. It should emphasize material joining,

conditions, flashing, etc. Refer to VT Facilities Procedure 15134 for more information on Hokie Stone Design and Construction procedures.

Provide a mock-up for pavers. Coordinate mock-up requirements with OUP.

Provide a detail of a mock-up wall section that is representative of all building materials proposed for the interior.

Mock-ups shall be stand-alone, separate, and not part of the final building. Approved mock-ups shall remain available for reference/review during construction, but shall be demolished and removed from project site prior to close out of project.

Specific mock-up requirements for renovation projects shall be determined by OUP.

1.7.2 Statewide Building Code Requirements

The building code for all University buildings is the current edition of the VUSBC with additional requirements and information in the DCSM.

The Virginia Department of Transportation (VDOT) has authority over structures (e.g., bridges) in the right of way that are not regulated by the VUSBC. Occupiable buildings located within the right of way are regulated by the VUSBC and are under the jurisdiction of the State Building Official.

1.7.2.1 Applicable Code

The A/E should estimate when working drawings will be completed and determine what code(s) will be in effect at that time. Where a new edition of the VUSBC is adopted during a project, the newest version shall apply to any project that does not have approved preliminary drawings as described below. Mixing of code requirements between two editions of the code is not permitted.

1. If preliminary drawings are approved during the 12 months before the effective date of a new edition of VUSBC, the applicable code will be designated by the UBO at the time of the preliminary approval.
2. If construction of the project does not begin within one year of the approval of the Schedule of Special Inspections (HECO-6), the UBO will clarify if a newer version of code applies. Prior to reactivating a project that has been inactive for a period during which the effective code has changed, the UBO will determine what code applies and will confirm any change of code in writing. The plans and specifications shall be revised as necessary to comply.

1.7.2.2 Code Clarifications

Code clarification requests should be made in writing to the UBO. The following are code clarifications that shall be applied to state-owned buildings and structures.

1.7.2.2.1 Buildings at Colleges and Universities

1. Buildings for business and vocational training shall be classified and designed for the (Use) Group corresponding to the training taught.
2. Academic/educational buildings having classroom-type education functions (including associated professor/teacher office spaces), shall include the following additional requirements:
 - a. Provide 72" minimum corridor widths in the classroom corridors.
 - b. Calculate the occupant load for each space based on Virginia Construction Code (VCC) Chapter 10 and the type of occupancy (not Group) of the space.
3. Buildings housing research, testing and science laboratories shall include a fire alarm system.
4. Dormitories, Fraternity and Sorority Houses and similar dwelling units with sleeping accommodations – provide one of the following:
 - a. Written University Policy which prohibits the use of these residences as housing for persons/groups/occupants for periods of less than 30 days, or
 - b. Design that complies with the most stringent requirements of both Group R-1 (Hotels) and Group R-2 (Dormitory)
5. Dormitory Occupant Load Calculations and Plumbing Fixture Calculations:
 - a. The number of occupants shall be computed per VCC Chapter 10 with the following changes to the maximum floor area allowances per occupant:
 - i. Dormitory sleeping areas – 1 occupant/50 net sq. ft.
 - ii. Other occupied areas – 1 occupant/unit of area based on function/occupancy of space
 - iii. Remaining areas – 1 occupant/200 gross sq. ft.
 - b. The minimum number of required plumbing fixtures shall be based on the occupant load and plumbing classification/occupancy, but will not include occupants identified in the “remaining areas.”

1.7.2.3 Accessibility Standards for University Facilities

The Americans with Disabilities Act, 1990: Title II, Subtitle A (and not Title III) of the Act applies to all University buildings and structures.

1.7.2.3.1 Conflicting Standards/Modifications

The ADA Standards for Accessible Design, latest edition, incorporates by reference editions of the International Building Code. The applicable code for the project shall be that which is adopted by the Commonwealth at the time of building design and permit, as described in DCSM section 1.7.2.1.

Where codes and standards conflict, the more stringent standard shall be used in designing accessible facilities. That is, the code or standard more favorable or advantageous to the disabled shall be used. As ADA is a federal law, modification or waiver of the ADA law requirements cannot be granted by the University.

1.7.2.3.2 Clarifications for University Buildings and Buildings on University Property

Accessible facilities must be provided at the completion of construction. Adaptable facilities do not meet the requirements for accessibility in state buildings and buildings constructed or placed on state-owned property.

Clarification for sections in the ADA Standards for Accessible Design, latest edition, are provided in the table below.

Category	Section	Clarification
Elevator Access	206.2.3	All passenger elevators shall be accessible to the disabled.
Elevator Access	206.2.3	Exception 4 does not apply. Residential facilities shall include at least one accessible route to connect each story and each mezzanine in multi-story buildings and facilities.
Stairways	210.1	All stairways shall be accessible to the disabled.
Stairways	210.1	Exception 3 does not apply. Aisle stairways for assembly areas shall comply with ADA Standards for Accessible Design, latest edition, Section 504.
Handrails	505.10	Handrail extensions shall not be turned to the side or back. Handrail extensions shall continue straight and parallel to the stair run.
Dormitories	233.3.1.1	Scope of fully-accessible dormitory rooms shall comply with this section; however, all dormitory rooms shall be located on an accessible route and doors to all rooms shall be accessible.

Category	Section	Clarification
Employee Work Areas	203.9	All areas and spaces normally occupied by employees or the public in state-owned buildings, individually or shared, shall be fully accessible.
Site Elements	201.1	Addition: Proposed Accessibility Guidelines for Pedestrian Facilities in the Public Right-of Way (PROWAG) dated July 26, 2011 shall apply to the design of site elements provided on state-owned property that are not regulated by the ADA Standards for Accessible Design, latest edition, and are not in the Virginia Department of Transportation Right-of-Way. The PROWAG guidelines are available for free download from the Access Board. These site elements are defined in PROWAG and are generally provided as part of an agency outdoor program.
Walk-in Coolers and Freezers	203.9	Walk-in coolers and freezers are considered employee work areas and shall comply with the requirements of Employee Work Areas, Section 203.9.
Unisex Toilets and Bathing Rooms	213.2.1	Comply with VCC Chapter 11 Section for Family or assisted-use toilet and bathing rooms.
Signs	216	Use the language from VCC Chapter 11 Section <i>Signage</i> as guidance for scope compliance.
Identification of Parking Spaces	502.6 and 2015 VCC, Section 1106.8	Signs (including the International Symbol of Accessibility, and identifying van-accessible parking spaces) shall be located 84 inches (2135 mm) maximum, and 60 inches minimum, above the finish floor or ground surface measured to the bottom of the sign. Additionally, provide a sign including the following language: PENALTY, \$100-500 Fine, TOW-AWAY-ZONE. The bottom edge of the PENALTY sign shall be no lower than 4 feet above the parking surface.
Cabinets	225.2	Under counter and over counter cabinets may be defined as the same "type" if the same arrangement of shelves is provided to comply with the reach ranges specified in Section 308.
Lavatories	606	Comply with VCC Chapter 11 Sections Lavatories and Sinks.
Assistive Listening Systems	706	Use the language from VCC Chapter 11 Section Special Occupancies: Assistive Listening Systems as guidance for scope compliance. The technical criteria in the ADA Standards for Accessible Design, latest edition, shall be incorporated into the design. The Hearing Loop (the Audio Frequency Induction Loop System or AFILS) is the preferred technology in most facilities.
Benches	903	Where interior or exterior benches are provided, 5% minimum or at least one in each area shall comply with the ADA Standards for Accessible Design, latest edition, Section 903. Grab bars and armrests are not required.
Maneuvering Clearance	305.7	Where either side of an alcove exceeds the dimension stated, the minimum maneuvering clearance shall be provided.

1.7.2.4 UBO Inspections

In addition to the required Special Inspections, A/E Inspections and Substantial Completion Inspection, the UBO will conduct construction inspections to assure that the work performed is in accord with the approved building permit documents. See DCSM section 8.2 and the VT CPSM for information on the scope of Special Inspections and the A/E inspections.

1.7.2.4.1 UBO Inspector Qualifications

Inspections will be made by an individual familiar with the project, with the knowledge, skill, and experience necessary to read and understand the documents, and meeting the following minimum criteria:

1. An individual certified by the Department of Housing and Community Development (DHCD) or by the International Code Council (ICC) in the specialty being inspected, and
2. A Virginia-licensed Architect or Engineer

1.7.2.4.2 Required Inspections

Inspections will be performed in accordance with the code and will include, but may not be limited to, the following:

1. Footing excavations and reinforcement material for concrete footings prior to placement of concrete.
2. Foundation systems during phases of construction necessary to assure code compliance.
3. Preparatory work prior to the placement of concrete.
4. Structural members and fasteners prior to concealment.
5. Electrical, mechanical, and plumbing materials, equipment and systems prior to concealment. This also includes fire suppression sprinkler systems, clean agent systems and fire detection and alarm systems.
6. All accessible restrooms, bathing rooms and public common area kitchens, lounges and other common use areas open to the public for required clearances, mounting heights and accessories.
7. Energy conservation material prior to concealment.
8. Any other Inspections the UBO deems necessary to ensure compliance with Code.
9. Final inspection.

Some of the required inspections may be included in the special inspections and the A/E inspections. Despite this, construction

inspections shall be made of the work as it is being performed to assure that conditions inspected by the special inspections and the A/E inspections are preserved.

1.7.2.4.3 VT PM Responsibilities

The VT PM shall notify the UBO to schedule inspections by sending a request a minimum of five business days in advance of the requested inspection date. The request shall contain the following:

1. Project Number
2. Project Name
3. Type of inspection required
4. Contact information to schedule the inspections
5. Email address for follow up to the UBO Inspection Reports

The VT PM shall provide email verification that comments generated by the UBO Inspection have been resolved.

1.7.2.5 Underground and Above Ground Storage Tank Systems

Technical standards related to USTS and AST are contained in the DEQ Water Division Regulations: 9VAC25-580, Underground Storage Tanks: Technical Standards and Corrective Action Requirements; 9VAC25-91-100, Facility and Aboveground Storage Tank Registration Requirements; and 9VAC25-91-130, Aboveground Storage Tank Pollution Prevention Requirements.

All permits for storage tank installation or removal shall be processed through the UBO. The VT PM shall include Environmental Health and Safety (EHS) in project design discussions and provide EHS with a copy of the permit.

1.7.3 Space Planning

The space management program facilitates the procedures associated with the University's space management policy. It supports the decision-making and approval process for all space initiatives. For more information, see Appendix C: University Space Management and the University Space Management website.

Virginia Tech has square footage guidelines for designing space based on Virginia state standards and the Commonwealth of Virginia A/E Manual.

This is a living program and, based upon feedback from users, materials and guidelines will be updated on the University Space Management website to

ensure continual improvements to the program for the benefit of the University community.

The following program space provisions, sizes, and criteria are program standards to be met unless a waiver has been approved by OUP. In building renovations, specified sizes and criteria may not be achievable in all cases. Space program spreadsheets or data sheets shall document such waivers.

1.7.3.1 Assigned Workspace

Assigned workspace includes offices and workstations that are assigned to individuals for long-term use. Sizing is based according to the position of the occupant as outlined in the table below. Workspaces can be designated as private, semi-private, or open. These designations are referenced when calculating circulation space.

Role	Square Feet per Occupant
President	350 sf
Provost	300 sf
Assistant/Associate Provost	250 sf
Vice Provost	250 sf
Vice President	250 sf
Dean	180 sf
Assistant/Associate Vice President	180 sf
Assistant/Associate Vice Provost	180 sf
Assistant/Associate Dean	180 sf
Executive Director	180 sf
Director	150 sf
Department Chair	150 sf
Senior Associate Director	150 sf
Assistant/Associate Director	150 sf
Professor	120 sf
Assistant/Associate Professor	120 sf
Collegiate Faculty	120 sf
AP Faculty	120 sf
Athletics Coach	120 sf
Senior Staff	120 sf
Research Associate	64 sf
Professor Emeritus	64 sf
Adjunct Faculty	64 sf
Professional Staff	64 sf
Office Manager	64 sf
Office Support Staff	48 sf
Graduate Teaching/Research Assistant	48 sf
Postdoctoral Fellow	48 sf
Research Assistant	48 sf

1.7.3.2 Shared Workspace

Shared workspace includes offices and workstations that are open to the public or are scheduled to individuals for short-term use (hoteling). Sizing is based on the desired layout for the space as outlined in the table below.

Layout	Square Feet per Workspace
Open	30 sf
Semi-Private	48 sf
Private	100 sf

1.7.3.3 Support Workspace

Support workspace accounts for shared areas such as kitchen/break rooms, file/general storage, reception and waiting areas, copy/mail areas, coat storage, and the like. An area of 30 sq. ft. may be portioned for each full-time occupant to account for this space.

1.7.3.4 Conference Space

The purpose of conference space is to provide a comfortable area for group discussion and collaboration. Sizing is based on the desired seating capacity for the room as outlined in the following table.

Seating Capacity	Square Feet per Room
4-6	150 sf
6-8	200 sf
8-10	250 sf
10-15	375 sf
15-20	500 sf

1.7.3.5 Support Space

Support spaces are to be incorporated into the design of new buildings and also into major building renovations where achievable. Recycling container storage rooms may not be needed for residence halls or dining halls. Coordinate with the VT PM for requirements for storage rooms and other specialized service rooms, such as hazardous material storage areas in research buildings.

Space Category	Area Guideline
All Gender Restrooms	min. 72 nsf, min. 1 per floor
Lactation Room	min. 54 nsf, min. 1 per building
Custodial Closets	min. 56 nsf, min. 1 per floor or 2 per floor if floor exceeds 18,000 nsf
Custodial Supply Closet	min. 100 nsf, min. 1 per building

Space Category	Area Guideline
Recycling Container Storage Room	min. 100 nsf, 1 per building
Housekeeping Supervisor Office	min. 100 nsf, 1 per building
Preventative Maintenance Office	min. 120 nsf, 1 per building

1.7.3.5.1 All Gender Restrooms

1. All gender restrooms shall be included in each new capital project and major renovations at Virginia Tech. Coordinate project specific requirements with OUP.
2. Every floor shall have one all gender restroom that complies with the latest edition of the ADA Standards for Accessible Design and is accessible to the general public. The all gender universal restroom shall be located nearby the men’s and women’s multi-user restrooms whenever possible.
3. Appropriate signage shall be displayed for the restroom as well as directional signage if it is not feasible for the restroom to be located near the men’s and women’s multi-user restrooms.
4. Each all gender restroom shall be designed as a single occupancy restroom with appropriate locking and closer mechanisms for operation of the fully accessible door. The door shall have an automatic operator.
5. The toilet, lavatory, and all required accessories shall be compliant with the latest edition of the ADA Standards for Accessible Design.

1.7.3.5.2 Lactation Rooms

1. Lactation rooms shall be included in each new capital project and major renovations at Virginia Tech. Coordinate project specific requirements with OUP.
2. Lactation rooms shall be accessible.
3. Provide key pad door access with an automatic locking mechanism upon closing.
4. Provide both a “Lactation Room” or “Nursing Room” sign and an “In Use/Available” sign for the door to the room.
5. Provide a minimum 6-foot long, 36-inch deep, 32-inch high countertop with an opening allowing seating at the counter. Provide cabinets above and below the counter; cabinets below counters shall have drawers.
6. Provide a sink with soap and a towel dispenser if a sink is not available in a close location to the lactation room.

7. Provide a minimum of two outlets in the room. One outlet shall be centered over the countertop.
8. If the room has windows, blinds or shades shall be provided.
9. Provide an option in the room for hanging coats.
10. Lactation rooms are not required on residential floors of residence halls. Coordinate with the VT PM.

1.7.3.6 Single-User Toilet Facility and Bathing Room Fixtures

The plumbing fixtures located in single-user toilet facilities and bathing rooms, including family or assisted-use toilet and bathing rooms that are required by section 1109.2.1 of the 2015 VCC, shall contribute, at an even ratio, toward the total number of required plumbing fixtures for a building or tenant space. Single-user toilet facilities and bathing rooms and family or assisted-use toilet rooms and bathing rooms shall be identified for use by either gender.

1.7.3.7 Lavatory Distribution

Where two or more toilet rooms are provided for each gender, the required number of lavatories shall be distributed proportionally to the number of water closets.

1.7.3.8 Labs

Lab space is sized according to the intended number of occupants, whether the lab will be used for research or instruction, and the level of intensity for anticipated lab activities.

Levels of intensity can be broken into the following three categories:

1. Highly Intensive: Wet labs and labs with large equipment. Highly intensive labs include Textiles, Dramatic Arts, most labs in the College of Engineering, College of Agriculture and Life Sciences, College of Natural Resources, Physics, Chemistry and College of Veterinary Medicine.
2. Moderately Intensive: Labs with moderate space requirements, including, Education, Psychology and Communications, Computer Science, Electrical, and GIS, and Music labs.
3. Non-Intensive: Labs requiring computers but little in the way of other supporting equipment. Non-intensive labs include Social Sciences, Mathematics and Statistics, Business, and Public Affairs.

	Highly Intensive	Moderately Intensive	Non-Intensive
Research Labs	260 sf/occupant	90 sf/occupant	25 sf/occupant
Instructional Labs	85 sf/occupant	60 sf/occupant	40 sf/occupant

1.7.3.9 Classrooms

Classroom space is sized according to both the desired quantity of seats as well as the seating arrangement that will be implemented. As seen in the following table, some seating configurations are not considered practical for large or small classrooms and therefore are not listed within certain seating capacity brackets.

Room Category	Seating Capacity	Movable chairs with tablet arms	Fixed chairs with tablet arms	Movable tables and chairs	Fixed table and chairs	Auditorium seating
Seminar / Small Classrooms	0-25	20 sf	17 sf	21 sf	21 sf	-
Classrooms	26-49	17 sf	17 sf	21 sf	19 sf	-
Classrooms & Lecture Rooms	50-99	15 sf	13 sf	19 sf	19 sf	15 sf
	100-149	-	13 sf	19 sf	19 sf	13 sf
	150-299	-	-	19 sf	18 sf	12 sf
	300+	-	-	19 sf	17 sf	12 sf

1.7.3.10 Circulation Space

Circulation space as calculated in this section is for the use by internal VT staff and is not used for calculations submitted to the Virginia Division of Engineering and Buildings (DEB) for Building Efficiency Ratios. See DCSM section 1.7.3.11 for DEB requirements.

Circulation space accounts for the portion of non-assignable area which is required for physical access to other spaces. It includes areas such as corridors, lobbies, elevators, stairs, etc.

To calculate circulation space, a Circulation Multiplier is applied to the net area. In general, more circulation space is needed for open workstation layouts than for private workstation layouts. For this reason, the VT Square Footage Calculator uses two Circulation Multipliers: one that is applied to workspaces, and another that is applied to all other space.

1. Workspace

The Circulation Multiplier for workspace is applied to assigned, shared, and support workspace subtotals. The multiplier itself is calculated based

on the ratio of open workstations to private workstations according to the following function:

Circulation Multiplier = (0.2) (open workstation count/total workstation count) + 0.4

This means that an additional 40% of workspace will be allocated for circulation if all workspaces are private or semi-private, and an additional 60% will be allocated if all workspaces are open.

2. Other Space

The Circulation Multiplier for all other space is set at a constant 0.4.

1.7.3.11 Building Efficiency Ratios

1.7.3.11.1 General

Building efficiency is the ratio of Assignable Area to Gross Building Area expressed as a percentage and is determined based on the definitions and calculation procedures shown below. The minimum building efficiency ratios are a composite of the ratios or factors taken from recognized standards and are based on the definitions and procedures shown below. The minimum building efficiency ratios are intended to provide achievable minimum standards for design of an efficient, functional layout.

The definitions and procedures described below shall be used to determine the “Building Efficiency Ratio.” Use the VCC definition of Building Area for determining the allowable area for the building for code compliance.

1.7.3.11.2 Definitions

Gross Area (GSF): The total area of all floors of a building measured to the exterior face of the exterior walls, or to the horizontal projection of the roof or floor above for areas that are not provided with exterior walls. This is not to be confused with the definition of “Area, Building” in the VCC which is used for building area limitations.

Assignable Area (ASF): The area or the sum of all areas on all floors of a building assigned to, or available for assignment to, an occupant, including every type of space functionally usable by an occupant except “Non-Assignable Areas” defined below. The area of a closet or private toilet within an office or suite space shall be included in the calculation of the assignable area of that space. Assignable square footage shall

include only program-related spaces; however, not all program related spaces are necessarily considered assignable.

Non-Assignable Area: The area or the sum of all areas on all floors of a building not available for assignment to building occupants but which are necessary for the general operation of the building. Non-assignable space areas include corridors, stairs, lobbies, foyers, atria, entry vestibules, walls, columns, elevators, mechanical shafts, toilets (common and public), janitors closets, custodial, circulation, mechanical, HVAC and utility spaces, structural areas and open (shaft and atrium) spaces.

Custodial Area: That portion of the non-assignable area which is the sum of all areas of the building used for its protection, care, and maintenance. These include janitor's closets, storage areas for custodial supplies and equipment, trash rooms, and custodial locker rooms.

Circulation Area: That portion of the non-assignable area which is required for physical access to other spaces, whether directly bounded by partitions or not. Circulation space includes corridors, elevator shafts, stairs, loading platforms, entry vestibules, foyers, atria, lobbies, tunnels and bridges. When determining circulation area, only spaces required for general access should be included. Aisles which are used for circulation within open office suites, auditoriums and other work areas are included in the calculation of the assignable area.

Mechanical Area: That portion of the non-assignable area designed to house mechanical/HVAC equipment, mechanical shafts, plumbing and sprinkler risers, electrical equipment rooms/closets, telephone and communications equipment rooms/closets, other utility services, and common or public (non-private) toilet facilities.

Structural Area: That portion of the non-assignable area which cannot be occupied or put to use because of the presence of structural features of the building. Included are columns, exterior walls, fire walls, and permanent partitions.

1.7.3.11.3 Calculations

The areas shall be determined from the actual floor plans for the facility. Assignable square feet (ASF) as a percentage of gross square feet (GSF) shall be no less than the ratios listed below. Exceptions to these building efficiency factors for state-funded projects must be approved by the

Director of DEB. Requests must be supported by written justification submitted by the University stating why these ratios cannot be obtained.

1.7.3.11.4 Building Efficiency Ratios

The baseline building efficiency ratio is 65% unless shown otherwise in the following table.

Building Type	Ratio: ASF to GSF
Office/Classroom Building (where classrooms are 29% or less of the assignable area)	70%
Classroom Building	66%
Classroom and Office Building (where classrooms are 70% or more of the assignable area)	66%
Engineering/Laboratory Building	72%
Instructional Shop Building	90%
Library Building	75%
Fine Arts Building	72%
Science Building w/Laboratories	65%
Physical Plant Service Building	85%
Auditorium/Theater	70%
Warehouse	93%
Maintenance Garage	85%

1.7.4 Hazards

1.7.4.1 Electrical

Field labeling of arc flash hazards shall be provided per NFPA 70E-2018, 130.5(H).

High and low voltage equipment in the same space shall be separated in accordance with 29 CFR 1910.303(h)(5)(ii).

1.7.4.2 Procedures for Asbestos Abatement

Asbestos-containing materials (building materials that contain greater than 1% asbestos) which can be disturbed by demolition or renovation work shall be abated in University buildings. Asbestos-containing materials (ACM) shall not be included in any new construction. The University shall have existing structures inspected by a Virginia licensed or certified asbestos inspector for ACM prior to submittal of the preliminary design in accordance with the VT Asbestos Operations and Maintenance Program through EHS and the DCSM.

1.7.4.2.1 Renovation/Demolition/Addition Projects

All ACM that will be disturbed as a result of a renovation, demolition, or addition work must be removed. All suspect materials must be physically sampled and analyzed. The asbestos inspector shall provide the University with a report of the inspection which indicates those places where samples were taken, the results of the analyses, and drawings which indicate those areas, if any, where asbestos was found and where ACM must be abated. The asbestos inspection report must be made available to the project A/E for information and use in preparing the project documents.

If ACM is found, the University shall have a Virginia licensed or certified asbestos project designer coordinate with the A/E to prepare asbestos abatement project design specifications. The designer's license or certification number, name and signature shall appear at the beginning of the asbestos specifications. The project designer shall indicate on the construction drawings all locations where ACM is to be removed or will be disturbed. The asbestos inspection report is to be included as an appendix to the project specifications. The VCC requires a permit prior to the removal or disruption of any ACM during the construction or demolition of a building or structure, including additions. This permit may be issued by the UBO.

ACM is to be removed by a Virginia licensed asbestos abatement contractor. The asbestos abatement contractor shall indicate on record drawings the areas where asbestos was abated, areas where asbestos was encapsulated, and areas where ACM exist but were left in place.

The University will ensure that asbestos abatement project specifications are followed by using a Virginia licensed or certified asbestos project monitor to monitor the project and perform air quality testing throughout the duration and at final completion of the project. No asbestos materials are to be removed without the asbestos project monitor being on-site.

1.7.4.2.2 Asbestos Disclosure Statement

The A/E shall note on the Title page of the drawings and in the specifications for all projects that no ACM shall be used on the project. All pages of the drawings shall have an Asbestos Disclosure Statement indicating one of the following:

1. An asbestos inspection was performed and no ACM was found. The asbestos inspection report is included as an appendix to the project specifications.
2. An asbestos inspection was performed and ACM was found generally in the areas indicated. However, the work in this project is not intended to disturb the existing ACM. The asbestos inspection report is included as an appendix to the project specifications.
3. An asbestos inspection was performed and ACM was found generally in the area(s) indicated. The asbestos inspection report is included as an appendix to the project specifications. The VT PM shall submit an application for permit to have the ACM abated by a licensed asbestos contractor using approved procedures as specified prior to issuing a Notice to Proceed to the General Contractor. Any ACM that is to remain and the new non-ACM shall be labeled accordingly. The asbestos abatement contractor shall mark up the record drawings resulting from its work to include areas where asbestos was abated and areas where ACM exist but were left in place. The General Contractor shall review and certify the locations where ACM was abated and areas where ACM was left in place as marked on the record drawings and will provide the drawings to the A/E.
4. An asbestos inspection was performed and ACM was found generally in the area(s) indicated. The asbestos inspection report is included as an appendix to the project specifications. ACM shall not be disturbed in this work except where specifically indicated and required. Where such actions are required, the Contractor shall have the ACM removed by a licensed asbestos Contractor using approved procedures as specified. The work required for asbestos abatement is permitted within the overall building permit issued. The ACM that is to remain and the new non asbestos-containing material shall be labeled accordingly. The asbestos abatement Contractor shall mark up the record drawings resulting from its work to include areas where asbestos was abated and areas where ACM exist but were left in place. The General Contractor shall review and certify the locations

where ACM was abated and areas where ACM was left in place as marked on the record drawings and will provide the drawings to the A/E.

1.7.4.2.3 Asbestos Contracting

The University has two contracting options for use in removal of asbestos from a structure, although option (2) is the preferred method:

1. A separate contract for removal of the asbestos prior to renovation, demolition or addition.
2. A contract where the abatement is an integral part of the renovation, addition or demolition project in which the General Contractor is licensed as an asbestos contractor or hires a licensed asbestos abatement subcontractor to perform the work.

1.7.4.2.4 Asbestos Related Work – Insurance Requirements

See SECTION 11(e) of General Conditions of the Contract for Capital Outlay Projects requires the asbestos contractor or subcontractor, as the case may be, to name the A/E as an additional insured on the Contractor's liability insurance with asbestos coverage. Where the A/E for the renovation project prepares the asbestos project drawings, the requirement of SECTION 11(d) to name the A/E as an insured party is waived. Professional Liability/Errors and Omissions insurance, with asbestos coverage, in an amount not less than \$1 million is required.

1.7.4.2.5 Demolition/Renovation Notification Requirements

Any proposed demolition within or of a building which contains asbestos must be reported 10 working days in advance of any demolition and 20 working days in advance of any abatement activity to the Virginia Department of Labor and Industry (DLI). The United States Environmental Protection Agency (EPA) and the DLI interpret these regulations to include non-friable materials which may be disturbed and rendered friable by the demolition (or renovation) activity.

1.7.4.2.6 Removal of Spray-on Fireproofing

See DCSM section 3.10.3.3 for requirements on the removal of spray-on fireproofing materials.

1.7.4.3 Procedures for Lead-Containing Paint

The EHS Lead Hazard Control Program provides requirements on the use, handling, and disposal of lead and lead-containing materials, including lead-

containing paint. Contractors shall follow all regulatory and DCSM requirements for lead-containing materials.

1.7.4.3.1 Lead Survey

For renovation, demolition, or addition projects, the University shall have the facility inspected for the presence of lead-containing paint by a Virginia licensed lead inspector or risk assessor and document all quantities and locations found. Where lead-containing paint is suspected or pre-determined, an estimated cost for any special procedures required shall be included in the cost estimate supporting the construction budget or budget request. In areas to be renovated, a copy of the lead inspection report shall be included as an appendix to the project specifications.

1.7.4.3.2 Lead Materials Disclosure Statement

The construction documents for all renovation, demolition and addition projects shall indicate all locations where lead-containing paint is to be disturbed or to remain, and shall include a Lead-Containing Paint Disclosure Statement indicating one of the following:

1. A lead-containing paint inspection was performed and no lead-containing paint was found.
2. A lead-containing paint inspection was performed and lead-containing paint was found in indicated areas. However, the work in this project is not intended to disturb existing lead-containing paint.
3. A lead-containing paint inspection was performed and lead-containing paint was found in the areas indicated. The Contractor shall be responsible for compliance with all VOSHA regulations regarding lead-containing paint protection for workers.

Following removal of lead-containing paint, additional Toxicity Characteristic Leaching Procedure (TCLP) tests in accordance with EPA guidelines shall be done on these materials to determine disposal requirements as hazardous waste or as ordinary construction debris. It is unlawful for materials identified as hazardous waste to be disposed of with ordinary construction debris.

1.7.5 Demolition of Buildings

Demolition of any building regardless of size and type shall be authorized by the Governor prior to proceeding (*Code of Virginia* § 2.2-2402, B.). This includes obtaining recommendations for approval to demolish the building/structure

from the AARB, the BOV, and the DHR. Requests for demolitions of existing buildings which must be done to allow for the new construction should be requested and approved before preliminary drawings for the new construction are prepared. The University is required to complete and submit the HECO-17.1 with attachments to request authorization to demolish any building or structure on state property.

1.8 COMMISSIONING

Commissioning as used in the DCSM, is the systematic process of review, documentation, inspection and performance testing implemented starting with design and extending through construction and occupancy of the facility, utilized to assure that the facility and systems meet the University's Requirements. The "Commissioning Authority" should ideally be an independent, third-party consultant hired by the University, who is responsible for the conduct of the commissioning scope of work. In some cases, the Contractor will be required to hire the Commissioning Authority and conduct the commissioning scope of work.

When commissioning services are not procured by the University or by the Contractor, the University may opt to provide the commissioning service by University Representatives. In this situation, the Contractor would be expected to support the commissioning process in the same manner as an independent third-party.

1.8.1 Objectives of Commissioning

The objective of commissioning of University facilities is to insure proper, reliable and safe operation of HVAC, plumbing, piping, electrical power and communications systems upon occupancy of each facility. Commissioning may also be utilized to assure the proper selection, installation and operation of other building systems, such as architectural systems, at the discretion of the University.

1.8.2 General Requirements

For most projects, the University will hire an independent, third-party Commissioning Authority or utilize the University's Facility Commissioning Authority to provide the scope of commissioning services defined herein and in DCSM section 6.2. These sections are intended to illustrate the scope of commissioning for which the Contractor will be responsible to cooperate and facilitate within the Project Documents. On some projects, Virginia Tech may determine that commissioning services shall be included within the Contractor's scope of work. In these cases, the project specifications shall

require the Contractor to appoint or hire the Commissioning Authority and include in their bid. On all projects unless otherwise approved, the contract documents shall include specifications which require the Contractor to cooperate, provide labor, assistance, materials, supplies and information, and otherwise facilitate the work of the Commissioning Authority (or to provide for and coordinate with the commissioning authority for commissioning services, where “Contractor commissioning” is specified.) Where third-party commissioning or the University’s Facilities Commissioning Authority is used, the independent Commissioning Authority will normally develop the “Commissioning Specifications” sections for inclusion in the Project Documents by the A/E of record. Where “Contractor commissioning” is utilized, the A/E will be responsible for developing the appropriate commissioning specifications sections. Virginia Tech shall be consulted on each project to determine who the Commissioning Authority will be, and to identify the specific systems to be commissioned for the particular project.

1.8.3 Systems to be Commissioned

Systems to be commissioned shall be at the discretion of the University and based on the project’s LEED goals and overall design.

1.8.4 Contractor Responsibility

The Contract Documents shall require the Contractor and subcontractors to cooperate, provide labor, materials, supplies and information where required to facilitate (or conduct, in the case of “Contractor commissioning”) the specified scope of commissioning work. The Contractor shall provide all specified assistance in a timely manner, at no extra cost to the University, and shall incorporate all commissioning activities and milestones into the overall Project Construction Schedule. Satisfactory completion and acceptance of all commissioning tests and reports shall be a condition for granting Final Completion of the project. All functional performance testing shall be completed in order to grant Substantial Completion of the project.

1.8.5 Project Closeout

Project closeout requirements shall include the review and recommendation of approval by the Commissioning Authority of Operation and Maintenance (O&M) Manuals and Warranty Information. Project closeout requirements shall include the completion of all testing and submission of all commissioning-related reports, certifications and manuals.

1.8.6 University Training

Contract documents shall require the Contractor to provide assistance, materials and services required to conduct training of University's personnel in the operation and maintenance of all major equipment and controls, and to cooperate with the Commissioning Authority in developing the training agenda and methods. Departments shall be notified of scheduled training events a minimum of two weeks prior to the start date of the training.

1.9 PROJECT CLOSE OUT

Every capital project which has an approved HECO-2 authorizing the project to be initiated shall be closed out by the completion and submission of a Project Completion Report, CO-14. This includes projects which may have been cancelled by the University and never constructed, projects where funds were reverted, projects which were combined with another project and the funds transferred, and projects where the funding was never allotted.

A project may be reported as 100% complete in the semiannual capital outlay status report when a Certificate of Use and Occupancy, HECO-13.3A, has been issued by the UBO. Upon issuance of the HECO-13.3A, the VT PM shall prepare the VT - New Building Information form and shall submit it to Risk Management. Coordinate with Risk Management for the latest version of the form.

The Project Completion Report, CO-14, shall be submitted to DEB as soon as practical after the project is physically complete and the associated administrative steps have been concluded, but no later than 12 months after the University occupies the building or the work has been accepted as substantially complete. Included in this generalized statement are such things as the Contractor's submission of warranty, operating manuals, maintenance procedures and other user required documentation; submission of the record drawings by the A/E; release of retainage to the Contractor and final payment for any outstanding invoices and other ancillary or associated work/equipment provided by vendors and contractors not associated with the general construction.

1.9.1 Final Cleaning

Final cleaning shall include, but not be limited to, cleaning in compliance with manufacturer's instructions, interior and exterior glass, mirrors, floors, other interior finishes, mechanical and electrical equipment, removal of stains and foreign substances exposed to view, vacuuming of clean soft surfaces, polishing of transparent or glossy surfaces, and other such requirements to leave the project area in finished condition. Final cleaning will be inspected by the VT PM.

1.9.2 Site Restoration

The Contractor is required to stabilize all disturbed areas in accordance with the project documents and the VTAS&S. Final site inspections will be completed by SID and the VT PM.

1.9.3 Record Reports

All projects require the submission of as-built information. Specific requirements for the different as-built documents are shown in the DCSM and the VTAS&S. Coordinate with the VT PM on specific requirements for the project.

1.9.3.1 A/E Statement of Preparation on Record Drawings and Specifications

The statement of preparation as shown below shall be affixed to each and every drawing sheet and on the cover and title page of the project manual of a completed set of "Record Documents." The drawings are not required to be sealed and signed. This criterion applies to documents created manually and in electronic formats. It is the expectation of the University that during the preparation of the Record Drawings and Specifications that the A/E is responsible to ensure that all information from Change Orders, RFIs, CNRs and other forms of document modifications used during the construction of the project are properly incorporated into the final Record Documents.

Statement of Preparation of Record Documents

These Record Documents have been prepared in part based on information provided by the Contractor in accordance with section 23, Plans and Specifications of the General Conditions of the Construction Contract. The A/E is not responsible for either errors in information provided by Contractor or others, or for information omitted by Contractor from its as-built drawings. Neither as-built drawings nor Record Drawings change or modify the duties and obligations of the A/E of Record to perform inspections in accord with section 16, Inspection and section 44, Inspection for Substantial Completion & Final Inspection or other requirements of the contract.

A/E of Record

Date

1.9.4 Operation and Maintenance Manuals/Data

A specific set of operating and maintenance instructions written for the specific project shall be provided to the University at the final inspection. This shall consist of a compiled document prepared by the A/E team for the project. These documents generally include the operation and control sequencing narrative, the control diagrams, an equipment chart indicating periodic maintenance requirements, and the operation and maintenance manuals for the equipment. All systems needing regular maintenance and requiring adjustments must be covered. The schedule for required minor and major maintenance must be included. Relevant design criteria and assumptions needed to understand the operation of the systems will be furnished in narrative form including the control systems settings and concept of operation. One hard copy and one electronic copy of the compiled documents, along with the Record drawings and specifications, shall be provided to the VT PM.

Manuals which do not provide specific data but simply reference the drawings, specifications and manufacturers are not acceptable.

1.9.5 Warranties

Specifications shall identify product warranties that differ from the standard manufacturer's warranty for the product.

1.9.6 Certificate of Occupancy/Final Inspection

Final inspection shall be in accordance with Chapter 8 of the DCSM.

1.10 REPORTING REQUIREMENTS FOR DEB

DGS is responsible for coordinating with, and collecting data from, other state agencies to compile two legislatively-mandated reports. These reports are the Capital Outlay Progress Report and the Value Engineering Utilization Report.

1.10.1 Capital Outlay Progress Report

1.10.1.1 Reporting Requirement

Virginia Tech is required to submit a report listing all active capital outlay projects. Active projects are defined as those for which an approved HECO-2 form has been issued. Projects are removed from the report the first reporting cycle following the submittal of the CO-14 form.

1.10.1.2 Reporting Frequency

The report is required to be submitted annually. The University's report is due to DEB by July 30 reporting data thru June 30 of the previous fiscal year.

1.10.1.3 General Instructions

Following are the general reporting instructions:

1. At least three weeks prior to the due date for the report, the University will be provided via email with an Excel spreadsheet of its portion of the most recent report submitted to the State Legislature.
2. The University shall edit this spreadsheet to show additions, deletions or changes in status as of June 30.
3. If a project shows no progress since the last report, an explanation must be given in the remarks column or on an attached sheet. Indicate the reason for lack of progress and what steps are being taken to get the project back on schedule.
4. Email the completed report to DEB at coforms@dgs.virginia.gov by July 30.

1.10.1.4 Specific Instructions

Following is an explanation of the data required in each column of the report. The data fields below are listed in the order in which they appear on the report.

1. Project Identification: 3-digit Agency or Sub-Agency Code, plus 5-digit Project Code under which the Appropriation is listed. Add the 3-digit Sub-Project code. Give abbreviated project title.
2. Biennium: Biennium in which the initial Appropriation was made. For even numbered years, use the double designation such as 2014-2016. For Appropriations made during the odd numbered years or mini-session, use 2015. Subsequent yearly or biennial additions or deletions to the Appropriation will be noted in remarks.
3. Appropriated Amount: Total of all funds appropriated for the project, including all funds added to or deleted from the project.
4. Obligated To Date: Value of all expenditures to date of all funds that are obligated by signed contract or purchase order.
5. HECO-2 Approved: Denotes date of approval of the initial HECO-2 by the Governor. Dates of revised forms are not required.

6. Design Percent Complete: Show percentages as follows:
A/E hired (CO-3)5%
Design Criteria (Schematics) Approved20%
Preliminary Plan & Specifications Approved40%
Working Drawings & Specifications Approved100%
7. Interpolate percentages to indicate status between points denoted. If plans are not required to be prepared either by Consultant or In-House personnel, then mark Column 6 as 'N/A'.
8. Contract Amount: Figure denotes accepted low bid amount, plus or minus increases or decreases as generated by approved change orders. When a Contractor is not utilized (i.e., when the work is performed by the University), then use the budgeted amount for construction.
9. Construction Percent Complete: Show percentages as follows:
Contract Awarded1%
Work Begun10%
Estimated Progress-InterpolateBetween 10% and 95%
Substantial Completion95%
10. Estimated Completion Date: As shown on the HECO-8 and as revised by change orders or University estimate of substantial completion when work is done by the University. Include in the listing the planned or estimated Construction Completion Dates for all Projects under design.
11. Remarks: Identify any variation to normal procedures in addition to those used as described in the explanation above (e.g., Project on hold, Contractor walked off site, or Project under litigation).

1.10.2 Value Engineering Utilization Report

1.10.2.1 Reporting Requirement

The Director of DGS is required by the *Code of Virginia* § 2.2-1133 to report to the Governor and the General Assembly on or before September 15 of each year, the following:

1. The number and value of the state capital projects where Value Engineering was employed.
2. The identity of the capital projects for which a waiver of the requirements of *Code of Virginia* § 2.2-1133, B was granted, including a statement of the compelling reasons for granting the waiver.

1.10.2.2 Reporting Frequency

The report is required to be submitted annually. University reports are due to DEB by August 1. This data reported shall encompass the period from July 1 through June 30.

1.10.2.3 General Instructions

At least three weeks prior to the due date for the report, the University will be provided via email with a data input form to complete. The University shall edit this form to list all VE studies completed during the reporting period. The University shall also list all projects which qualified for a VE study, but for which a VE study was not prepared. The reason for not having a VE study prepared shall be provided (i.e., a waiver granted because the project was ...).

Email the completed report to DEB at capout@dgs.virginia.gov by the specified due date.

CHAPTER 2 - DOCUMENT AND DRAWING REQUIREMENTS

2.1 BASIS OF DESIGN NARRATIVES

The Basis of Design and Code Compliance Summaries are narrative descriptions of the project submitted as a bound presentation of facts sufficiently complete in accord with the following format to expedite University reviews of the appropriate submittals. Non-capital renovation projects may not require a complete basis of design narrative. Coordinate specific requirements with the VT PM.

2.1.1 Schematic Basis of Design Narrative

General computations supporting system selection; member depth; floor-to-floor heights; mechanical and electrical loads are expected with the Schematic Basis of Design Narrative. The Schematic submittal shall include a Basis of Design Narrative which, as a minimum, provides the following information in narrative or tabular format:

1. Capacity and type of occupancy
2. Functions to be housed in the building
3. Proposed building location on the site and how this project is located in relation to other nearby facilities
4. Indicate the type of construction proposed: protected or unprotected, noncombustible or combustible, and VCC Construction Type classification
5. Outline description of basic materials
6. Statement of compliance with the VT CAC
7. Future construction or expansion to be accommodated, if any
8. Style and character of building desired
9. Structural design live loads, wind loads, and seismic criteria used
10. Type of foundation system selected
11. General description of any proposed fire suppression systems (clean agent, chemical, etc.)
12. Provide a general description of any proposed fire sprinkler systems.
13. Identify applicable NFPA Standard (cited by the VCC) which provides the minimum requirements for the design, installation, testing, inspection, approval, operation, and maintenance of the proposed fire sprinkler or fire suppression system. Indicate the water supply to the proposed building and whether or not a fire pump will be required. (Calculations to support this position are desirable at this phase but are not required.)

14. Provide a description of not less than three different types of HVAC systems to be analyzed by life cycle cost and energy analysis in accord with DCSM section 1.4.3.
15. Provide estimated heating and cooling loads.
16. Provide a description of the fuel selected to be used. For new construction and for renovations where fuel sources are to be changed from current sources, a life cycle cost and energy analysis in accord with DCSM section 1.4.3 shall be performed.
17. Total square foot area per floor and per building
18. Total cubic foot volume
19. Number of beds, seats or parking spaces, where applicable
20. Total estimated construction cost based on the schematic documents
21. Total proposed project budget

2.1.2 Preliminary Basis of Design Narrative

In the executive summary, the A/E shall provide a statement that the project will abide by the VT Climate Action Commitment stated in the 2013 Presidential Policy Memorandum No. 262.

Design computations, sizing of members or conductors, details of connections, for example, are expected to accompany the Preliminary Basis of Design or Code Compliance Summary narrative submittals.

The following format is for a new building type construction project but is applicable to renovation and addition projects by addressing those portions relevant to that particular project. When a project consists primarily of mechanical, electrical, structural, or another discipline, the Basis of Design shall provide more detailed information for the major discipline. The narrative shall address or list the factors indicated for each section. Data may be presented in tabular form where appropriate.

2.1.2.1 Architectural

1. Describe functions to be housed in the building and the applicable VCC use group classification(s). Include copy of the minimum space/area requirements and adjacency criteria used to develop the design (Virginia Department of Planning and Budget form S-1 or equivalent).
2. Provide analysis of VCC and referenced standards (and NFPA 101, Life Safety Code, if applicable) requirements of all occupancies involved. Determine occupancy classifications and compute design occupant load, number of units of exit and other requirements. Describe unusual or

critical code requirements and indicate how such requirement will be met.

3. State the VCC construction type. Describe construction systems/materials proposed to achieve the construction type/fire resistance rating.
4. Computation of gross floor area in accordance with form DGS-30-219, Area Calculation Worksheet, guidance and of the building efficiency factor/ratio. Gross floor areas should be indicated on the drawings.
5. Provide preliminary floor plans, elevations, building cross section and other drawings as required by DCSM section 2.6. Floor plans should indicate the location of all built-in equipment and fire walls.
6. Statement as to the types of thermal insulation to be provided, where required, and the value of the “U” factors for the various portions of the structure (roof, walls, floors, etc.). Also describe all architectural energy conserving features to be incorporated.
7. Describe materials for all major items of construction and all interior and exterior finishes. The description of finishes shall be accomplished by the use of a finish schedule. The finish schedule (on the included drawings) shall identify spaces and interior building material finishes.
8. Provide furniture and equipment footprint drawings in preliminaries reflecting the University’s updated equipment list which show the end result of the architect’s space planning effort. The furniture footprint demonstrates the designer’s plan for the various functions that are housed in the facility. The designer shall use standard furniture sizes to demonstrate adequacy of space and to communicate utility and service requirements to development, these drawings are not included in the final construction bid package.
9. A description of items not considered to be a permanent part of the structure, such as work benches, shelving, bins and removable partitions. (Show also on furniture footprint drawings.)
10. Where high-density file storage systems are proposed, provide data to demonstrate acceptable loading capacity.
11. Analyze the design for compliance with acoustical requirements. List areas of high noise and vibration and acoustic design principles applied. Is an acoustical consultant or specialist required for the project?
12. Describe design features to make the facility fully accessible and compliant with the ADA Standards for Accessible Design, latest edition.
13. Equipment rooms of ample size shall be provided with consideration being given to adequate allowances for access, maintenance, repair and

easy removal of units. Room dimensions shall not restrict equipment items to the products of any single manufacturer. The A/E should assure that equipment of more than one manufacturer can be accommodated in the space allocated. This policy will not be interpreted as sanctioning an increase in equipment space to accommodate some particular manufacturer's product when such would result in structural costs being greater than the probable resultant saving in equipment costs.

14. Describe special construction features incorporated into the facility such as barred windows, special wall/roof construction, etc.

2.1.2.2 Structural

1. Description of foundation conditions, type of foundation to be used, method by which the allowable bearing values are to be determined, and maximum allowable bearing capacity for the foundations. Geotechnical information including field boring notes and foundation design recommendations shall be submitted with the preliminaries.
2. Statement of the type of construction adopted and reason therefore, with capacity, dimensions, or other size criteria. List of materials selected with design strengths and ASTM, AISC, ACI, etc., standards to be specified.
3. Special features to be included in the structure which are not evident from the drawings.
4. Description of the structural floor and roof systems proposed, with length, spacing and size of principal members (e.g., for beam and girder).
5. Description of the Lateral Force Resisting System proposed with appropriate materials and dimensions.
6. Statement of live loading to be used, to include floor loads and wind, snow, and earthquake loads, with data to justify.
7. Statement of any special considerations that affect the design (special corrosion resistance requirements, detention facilities, cranes, etc.).
8. The usual accepted means of structural system selection is economy. Demonstrate this with cost comparisons of various appropriate framing systems such as:
 - a. Typical bay member sizing and cost comparisons of alternate structural systems;
 - b. Horizontal force resisting system for wind and earthquake;
 - c. Consideration of unusual geometry (long span, high bay, deep cuts, etc.);
 - d. Consideration of heavy equipment supports.

9. Where high density file storage systems are proposed, provide data to demonstrate acceptable structural loading capacity.
10. Details using horizontal HSS tubes as beams: Do not recommend using HSS Tubes as horizontal beams where they are required to be fire rated. There is no UL listing for this condition. HSS tubes used as columns and X-bracing can be UL listed.
11. Helical piers: if the engineer wishes to use helical piers, a recommendation must be made by the soils engineer in the soils report or supplemental report for the correct design.

2.1.2.3 Plumbing

1. Describe system to be utilized on each part of the project.
2. Determination/calculation of number of each type of fixture based on approved VCC occupancy load. Indicate types and quality standards in narrative and on preliminary drawings.
3. Estimated number of fixture units and water demand in GPM for all plumbing fixtures.
4. Estimated maximum and minimum water pressure at each building and indicate if booster pumping will be required.
5. Type, size and design temperature of domestic water heater and distribution system.
6. Also, a statement as to whether heat recovery is contemplated for domestic water heating.
7. Design temperature of domestic hot water distribution system and extent of recirculation system within building.
8. Indicate materials to be used for each piping system.
9. Address any special needs such as sumps, interceptors, pumps, pipe guides, lift pumps for sewerage, etc., and indicate tentative sizes, capacities and quality standards to be specified.

2.1.2.4 Heating, Ventilating, and Air Conditioning

1. Design Conditions
 - a. Describe and/or list the indoor and outdoor design conditions to be used in the design of systems for this project.
 - b. HVAC systems shall be selected based on the lowest life cycle cost as determined by a life cycle cost and energy analysis in accord with DCSM section 1.4.3. Provide an analysis of not less than three different types of HVAC systems. The results of the analysis shall be presented for review with preliminary submittal

- c. For new construction and for renovations where fuel sources are to be changed from current sources, the fuel sources shall be selected based on the lowest life cycle cost as determined by a life cycle cost and energy analysis in accord with DCSM section 1.4.3. The results of the analysis shall be presented for review with preliminary submittal.
2. Heating
- a. Describe the source of heat energy which will be used, such as extension of central high pressure steam with meter, hot water with meter, or independent heating equipment with type of fuel to be utilized. Also explain why this source was selected in lieu of other available sources. Where there is a possibility of more than one type being economical a computerized analysis should be included to justify the selection.
 - b. Briefly describe and/or show on the drawings the type and routing of the system proposed to convey the heat source, if applicable (e.g., 100 psig low level, above ground steam and condensate lines on concrete support, interconnecting to the existing system at manhole no. 150 and traveling due north into the mechanical equipment room). Indicate the maximum hourly production of condensate.
 - c. Describe and/or provide schematics of the type of heating medium and system to be used within the buildings. Also include reasons for selection of this system over others available.
 - d. Describe the HVAC Control System. A specific type of control system will be specified.
3. Ventilation
- a. Indicate the quantity of outside air per person in all areas, the type of filtration, and whether Occupational Safety and Health Administration (OSHA) requirements are applicable.
 - b. State if smoke removal/control systems are to be employed.
 - c. Describe the operation of the system in summer and winter modes.
4. Air Conditioning
- a. Provide a complete description and/or schematics of the air conditioning system proposed including an explanation of why this system is preferred over others. Also indicate locations of major components of the system. For larger systems which qualify under Energy Conservation, a computerized comparison between at least two systems is required.
 - b. Define areas to be air conditioned.

- c. Identify special humidification or de-humidification requirements, as well as special filtration requirements.
 - d. Describe any special architectural features being incorporated to reduce cooling loads. Also, any features being incorporated in the mechanical system which would reduce energy consumption should be separately discussed.
5. **Combination Systems:** For systems in which the heating, ventilating and/or air conditioning are combined, repetition may be eliminated by consolidating the aforementioned requested information. Describe changeover procedures and requirements.
 6. **Energy Conservation:** Computer energy analysis (block load type) for buildings larger than 8,000 square feet requiring heating and cooling and larger than 20,000 square feet requiring heating only shall be used to study energy conservation features. Concurrence of systems to be studied should be obtained prior to conducting study. If a valid computer analysis was prepared during the Budget Study Preparation for the project, this may suffice. When computer analyses are performed, the total annual energy consumption estimate should be clearly stated.
 7. Briefly describe the controls for each system and indicate intended sequence of operation.
 8. Briefly describe testing and balancing requirements to be required.

2.1.2.5 Environmental Pollution Control

Identify expected environmental pollution and the proposed method of control. A detailed description will be necessary for those facilities directly related to controlling air and water pollution such as sewage treatment plants, industrial treatment facilities, incinerators, smoke elimination facilities, and other similar projects. When subsurface tile filtration is being considered for sewage disposal, a soil percolation test will be required for each such disposal system. List all environmental control permits and notifications required.

2.1.2.6 Asbestos, Lead-Based Paint and Hazardous Materials

The A/E shall include a statement in the Basis of Design addressing asbestos, lead based paint, and other hazardous material (including leakage from underground storage tanks) presence or potential presence on the project. Indicate if the University has secured an asbestos, lead based paint, or hazardous material investigation of the project area for renovation projects. Indicate how the presence of these materials will affect this

project (removed by separate project, removal included in this project, left in place, etc.). If work is by separate contract, indicate if phasing of work or a delay of this project is anticipated.

2.1.2.7 Special Mechanical Systems

Provide a description of any special mechanical systems such as compressed air, hydraulic, nitrogen, etc., including an explanation of the medium source.

2.1.2.8 Central Heating Plants and Heating Plant Additions

1. Prepare an energy analysis in accordance with DCSM section 1.4.3 and submit an energy analysis summary. Describe criteria and assumptions in narrative. Describe purpose and justification of systems proposed.
2. Describe environmental constraints such as applicable regulations, liquid wastes, gaseous emissions, treatments required, etc.
3. Describe new boilers including rating, flow, temperature, pressure and type.
4. Describe control systems.
5. Describe any new auxiliaries to be added and what source of power will be used for their operation.

2.1.2.9 Refrigeration (Cold Storage)

Identify areas to be refrigerated, indicating their usage and temperatures to be maintained.

Describe type of refrigeration equipment and systems.

2.1.2.10 Thermal Storage

1. Describe the type (static or dynamic) of storage being considered.
2. Provide preliminary cooling profile.
3. Provide preliminary equipment and tank sizes.
4. State how the A/E proposes to conform to State Procurement requirements when specifying thermal storage system and components.

2.1.2.11 Fire Protection Systems

1. Describe type(s) of automatic sprinkler and gaseous extinguishing systems to be utilized and note locations to be protected.
2. Describe fire detection and alarm systems including location of detectors, manual stations, audible devices, control panels, etc.
3. On the drawings indicate location of water supply pipe location and main entrance to buildings.

4. Also indicate location of gaseous extinguishing system equipment and supplies and location of fire department connection and post indicator valve.
5. Provide the following information about sprinkler systems:
 - a. Hazard classification of occupancy and applicable Code reference.
 - b. Water supply available at point of connection (static pressure and residual pressure at design flow). This data must be based upon flow tests at or near the point of connection and must appear in the Basis of Design. Indicate on drawings the location of flow test.
 - c. Provide a description of the Fire Pump Components and the Sequence of Operation specific to this project.
 - d. Approximate water demand for sprinkler system.
6. Statement of adequacy/inadequacy of water supply and planned upgrades by local jurisdiction, if any.

2.1.2.12 Electrical

1. Interior distribution systems:
 - a. Electrical characteristics (phase, voltage, and number of conductors in main distribution circuits).
 - b. Breakdown in tabular form of the estimated connected load to show:
 - i. Lighting load and convenience outlet load separately.
 - ii. Power load for building equipment such as heating, air conditioning, etc.
 - iii. Loads for special operating equipment such as compressors, generators, pumps, and for power receptacles being provided to energize special equipment. Apply an appropriate demand factor to each to compute total demand load.
 - c. Type of wiring system, such as rigid conduit, electrical metallic tubing, nonmetallic sheathed cable, etc., and where proposed to use. The National Electrical Code® (NEC) prohibits embedding aluminum conduit in concrete unless protected. Design shall be sure that conduit, pipe, bars, anchors or other aluminum parts are not embedded in concrete unless protected.
 - d. Type of conductors, such as rubber insulated, thermoplastic insulated, polyvinyl chloride jacket, etc., and where proposed to use.
 - e. A statement describing proposed pertinent standards of design, such as voltage drop (include calculations), lighting intensities (include calculations), and type of lighting fixtures, and a statement regarding the use of selective switching or other energy conserving features.

- f. A determination of short-circuit duty required for all service entrance protective devices and switchgear (usually available from power company). Include cost premiums in cost estimate.
 - g. Type and arrangement of Cable Television Systems (CATV), Closed Circuit Television Systems (CCTV), Nurse Call, intercom, sound, assistive listening systems, signal, and fire alarm systems. Identify number and location of telecommunication outlets (telephone, computer, word processing, etc.). Obtain information from the using activity.
 - i. Space required for telecommunication equipment, point of connection to telephone utility, size of incoming duct/conduit and size of equipment mounting backboard to be provided.
 - ii. Statement relative to interface provision for multi-use systems (intercom, telephone, etc.). A/E must provide all facility support for proposed telephone equipment installations (e.g., conduit, duct, and backboard). Design and procurement of telephone system to be accomplished by the University.
 - iii. A/E must provide an analysis of recommended assistive listening systems for all Special Occupancies.
 - h. Indicate interior lighting on lighting plans.
2. Outside distribution systems:
- a. Contact the Utility Companies for location and characteristics of nearest service facility capable of meeting project supply requirement and cost-of-service information for economic analysis.
 - b. Statement relative to the adequacy of the primary supply at the point of take-off. If primary source is inadequate, state measures proposed to correct the deficiency.
 - c. Electrical characteristics of power supply to site including circuit interrupting requirements and voltage regulation.
 - d. Estimate of total connected load and resulting kilowatt demand load by applying proper demand and diversity factors, if a group of loads is involved.
 - e. Basis for selection of primary and/or secondary distribution voltage.
 - f. Type of conductors, such as copper or aluminum, and where proposed to be used.
 - g. A statement describing pertinent standards for design, such as voltage drop, physical characteristic of overhead or underground circuits, type of lighting units and lighting intensities.

- h. Type and adequacy of signal and fire alarm systems, including a statement as to spare capacity on fire alarm circuit. The importance of early resolution of the fire protection requirements cannot be overemphasized.
- i. Type, adequacy and routing of supporting structure(s) for telecommunication cable.

2.1.2.13 Electronic Systems

1. System engineering concepts. Describe the proposed type of system, its functions and the interrelationships if the system is a multi-use system.
2. Indicate circuit requirements.
3. Indicate equipment selection in such categories as: University furnished equipment; standards manufacturers or commercially available items; and special equipment.
4. Describe site or location considerations.
5. Describe bonding and grounding requirements.
6. Describe communication and control cables and radio links.
7. Identify test equipment, repair shop, and spare parts storage requirements.
8. Describe equipment, instrumentation, arrangement, and space requirements. Indicating requirements for racks, consoles, and individual mountings. Provide the most economical design in first cost, operation and maintenance costs, and operating conditions conforming to best engineering concepts.
9. Identify wiring and cabling requirements plus terminations.
10. Identify power and lighting requirements, including emergency or standby requirements.
11. Describe air conditioning, including humidity and dust-control requirements.
12. Identify interference and clearance requirements.
13. State security requirements for Security Entry Control System.
 - a. Identify separately from the other project elements the requirements for Intrusion Detection Systems (IDS). Any of the following items and their interconnecting circuits may be considered part of an IDS:
 - i. Annunciation Panels and Cabinets
 - ii. Visual and Audible Annunciators
 - iii. Magnetic Switches
 - iv. Proximity Sensors
 - v. Volumetric Sensors

- vi. Wire Grids
 - vii. Vibration Detectors
 - viii. Power Supplies Integral to Items on this List
 - ix. Closed Circuit Television Cameras and Monitors, and
 - x. Video Recorders used for Intrusion Detection Purposes
 - xi. Access Control Systems
- b. IDS installation can be divided into three general functional categories:
- i. Sensitive compartmented information facilities.
 - ii. Conventional arms, ammunition, and explosives storage sites (AA&E).
 - iii. All other (including, but not limited to, communication facilities, special training facilities, special operational facilities, intelligence facilities, etc.).

Describe access control equipment (versus IDS) when required and outline locations, function, and area of control.

2.1.2.14 Energy Monitoring and Control System (EMCS)

1. Indicate if any EMCS will be utilized.
2. Indicate if the EMCS will be stand alone or tied into central system.
3. Indicate if a Sole Source authorization is required for tie in. See the VT CPSM for additional information.
4. Describe the EMCS proposed to be used.

2.1.2.15 Site and Landscaping

1. Describe site and facility location and give reasons for selection and orientation.
2. List and/or describe utilities available at the site.
3. Describe existing vegetation, bodies of water, topography, and soil conditions.
4. Describe existing site improvements to remain, to be altered, and to be demolished.
5. Describe existing pedestrian and vehicular access, roads, sidewalks, and parking to include accessibility for the disabled. See DCSM section 1.7.2.3 for accessibility standards.
6. Describe proposed site improvements.
7. Describe proposed contours, bodies of water, and landscaping improvements.

2.1.2.16 Water Supply

1. Describe the existing system including, but not limited to, the type, capacity, condition, present water use, and unsatisfactory elements.
2. State type of construction proposed, materials for water mains, type of well, etc.
3. State design factors with present and projected design population loads for sewage treatment plants. Coordination with appropriate state/local regulatory agencies is required.
4. State materials to be used for sewer systems and sewage treatment plants.
5. Identify standards (federal, state, local) governing the design.
6. Describe the impact of steam condensate and cooling water discharges on existing sewer lines and sewage treatment plants and the estimated cost of distribution and treatment of this additional loading.

2.1.2.17 Sewers and Sewage Disposal Systems

1. Describe the existing system indicating particularly the type, capacity, condition, present flow and unsatisfactory elements.
2. State degree of treatment necessary by effluent requirements and units needed to treat.
3. State design factors with present and projected design population loads for sewage treatment plants. Coordination with appropriate state/local regulatory agencies is required.
4. State materials to be used for sewer systems and sewage treatment plants.
5. Identify standards (federal, state, local) governing the design.
6. Describe the impact of steam condensate and cooling water discharges on existing sewer lines and sewage treatment plants and the estimated cost of distribution and treatment of this additional loading.

2.1.2.18 Roads, Driveways, Parking Areas and Walks

1. State general soil conditions, with a brief outline of soil exploration and testing performed.
2. Indicate CBR value and pavement recommendations. (Show typical paving section on the drawings.)
3. Describe the type and volume of traffic, controlling wheel loads and types or classes of roads under consideration. Justify any deviation from criteria thickness for these classes.

2.1.2.19 Dust and Erosion Control

Dust and erosion control will be considered an integral part of all design and construction projects. Such controls will be generally limited to areas actually scarred or denuded in the process of constructing a project. Dust and erosion control will not be confused with landscaping. Preliminary submittal will contain the necessary design data, and costs for dust and erosion control measures where applicable. The Basis of Design will include a narrative regarding the type of treatment selected, affected areas, and reasons for selection of type and determination of areas.

2.1.2.20 Fencing

State type, heights, and justification for fencing.

2.1.2.21 Stormwater Management

Describe the measures to be taken and/or features/structures required to comply with the VTAS&S.

2.1.3 Post Construction Basis of Design Update

The A/E is required to update the basis of design narratives to reflect the final design of the building. This includes any system changes during development of working drawings as well as any construction changes.

2.2 COST ESTIMATE STANDARDS

Detailed descriptions and requirements for cost estimates are provided in DCSM section 2.2.4. A detailed cost estimate consistent with the level of design is required from the A/E with each submittal. A Building Cost Summary form shall be completed indicating the estimated cost of each system included in the project. Non-capital renovation projects may not require detailed cost estimates. Coordinate specific requirements with the VT PM. In addition to a printed copy of the Building Cost summary form and estimate backup/details, provide an electronic copy of the completed Building Cost Summary with each estimate. The system quantity, system unit cost and unit cost per building square foot shall be shown on the form. Backup estimating information, including quotes of estimated cost for major items of equipment or built-in systems, shall accompany the Building Cost Summary form. An independent cost estimate is required with the preliminary submittal. If the preliminary submittal is waived or not required, the independent cost estimate shall be included in the working drawings submittal. On large projects, where construction cost versus budget is in doubt, the University may elect to obtain an independent cost estimate based on the final plans and

specifications prior to bidding. All cost estimates shall be submitted using ASTM Unifomat II cost breakdown structure in form DGS-30-224.

2.2.1 Estimator Qualifications

Capital project estimate submissions must be prepared by professional cost estimators. Certification as a cost engineer by the Association for the Advancement of Cost Engineering (AACE), or as a certified professional estimator by the American Society of Professional Estimators (ASPE), is supporting evidence of an estimator's qualifications, although it is not required.

2.2.2 Project Cost Summary

The University shall submit a completed Building Cost Summary worksheet(s) to DEB (form DGS-30-224) along with an updated CR-2 (form DGS-30-198) indicating all of the anticipated soft costs for the project.

2.2.3 Ethics

The standards of practice described in the Canons of Ethics published by the AACE and the ASPE, and available on both their Web sites, apply to all estimating services.

2.2.4 Cost Estimate Requirements and Format

2.2.4.1 General

All estimates shall be prepared in the systems format and shall be summarized on a Building Cost Summary form. The Building Cost Summary form utilizes ASTM Unifomat II cost breakdown structure in ASTM Unifomat II Classification Standard which has been extracted, with permission, from ASTM E1557-09 Standard Classification for Building Elements and Related Sitework-UNIFORMAT II. The Building Cost Summary (form DGS-30-224) is available as a spreadsheet template. A printed copy of the Building Cost Summary form and the associated supporting estimate backup shall be provided with each submission. Unless waived by the Director of DEB, the University shall require their design and cost consultants to submit an electronic copy of each completed Building Cost Summary form. The electronic copy of the form (i.e., spreadsheet) may be submitted to DEB either on removable electronic media, or as an email attachment.

The estimate backup material for each submittal shall be consistent with the level of design required for that submittal. Accurate quantity take-off,

inclusion of all appropriate standard systems, and accurate unit prices for the project's location are fundamental to the development of a good cost estimate. Properly prepared cost estimates provide a check of the plans and specifications for constructability, coordination, conflicts, discrepancies, and omissions. They are used to establish/ verify budgets, to develop historical data for future estimates, and for verification of the Contractor's Initial Schedule of Values (CO-12).

The estimate at each submittal is expected to reflect the A/E's or University's Independent Estimator's best information and experience. Pricing must reflect all requirements of the contract plans and specifications. Estimate backup may be prepared manually or by utilizing computerized estimating programs, however, the estimate must be summarized using the Building Cost Summary spreadsheet. A detailed breakdown of the components of each system or assembly shall be calculated, quantified and cost-estimated. The total system cost, a system quantity, a unit cost for the system, and a unit cost per square foot of gross building area shall be calculated for each system and summarized on the Building Cost Summary spreadsheet.

Separate estimates will be prepared for each new non-identical building, structure, or addition costing over \$50,000 contract cost. Costs of alteration work to existing buildings will not be included with the building addition costs. When one construction contract contains more than one type of work (new construction, repair, equipment installation, etc.), the estimate shall be structured such that each type of work is identified separately. In addition to an overall or master summary sheet, each type of work requires a separate summary sheet. Costs from these separate summary sheets must be directly transferable to the master summary sheet. Refer to the notes on the Building Cost Summary form.

When the estimates exceed the approved or proposed construction budgets, the University, in consultation with their design and cost consultants, shall describe how they will address this issue.

2.2.4.2 Schematic Design/Project Criteria Phase Estimate

The Schematic Design Construction Cost Estimate shall be developed in the "systems" format. Each system shall include a description or listing of the components or items included in that unit cost. To the extent possible, major systems or commodities should be quantified. Where quantification is

not practical, the key assumptions made while developing the estimate must be described.

2.2.4.3 Preliminary Phase Estimate

The Preliminary Estimate shall be based on a materials take-off from the preliminary documents. The estimate for this submittal shall reflect cost based on reasonably accurate take-off of material/systems consistent with the level of design. For those elements of the project where the status of design does not permit a reasonably accurate take-off of quantities or firm pricing of individual items of work, system unit prices may be used. Lump sum costs are not acceptable. Use of empirical costs shall be minimized. The Preliminary Building Cost Summary backup shall use the systems format. If the difference between the A/E cost estimate and the Independent cost estimate is 10% or greater, the University shall provide a reconciliation of the two consultant's estimates.

2.2.4.4 Final/Working Drawings Phase Estimate

The A/E shall provide a final estimate based on the working drawings and specifications and shall be prepared using the systems format. A full and accurate description of each system shall be provided in the estimate. Quotations shall be obtained for all items of substantial quantity or cost. Documentation must be provided for all major items of equipment included in the project. "Estimated prices" are considered to be quotations that are reasonable expectations of the price a Contractor will be expected to pay. Estimates that do not conform to these formats and information requirements will be returned for revision. Separate estimates must be prepared for each additive bid item included in the documents and shall be in the proper format.

2.2.4.5 Summary of Estimate Submission Requirements

Design Phase	A/E Estimate	University's Independent Estimate
Schematic Phase	Required*	Optional (at owner's discretion)
Preliminary Phase	Required*	Required*
Working Drawing Phase	Required*	Optional (at owner's discretion)

* The following are required:

1. Submit a hard copy of the Building Cost Summary sheet(s) and supporting estimate backup to DEB
2. Submit an electronic version of the completed Building Cost Summary worksheet(s) to DEB

2.3 GENERAL DRAWING REQUIREMENTS

The UBO/SID may waive certain drawing requirements based on the size and scope of the project. Coordinate with the VT PM. All drawings shall have a font size that allows it to be legible and easily readable.

2.3.1 Code Compliance Documents

HECO-4, HECO-5, and HECO-6 form usage is dependent on the type of project delivery method. These forms are generally used for Design-Bid-Build projects, but do not correlate with Design-Bid or CM at Risk delivery methods. For Design-Build, submit the DGS-30-471 request form. For CM at Risk, submit the DGS-30-456 request form.

2.3.1.1 Code Compliance Drawings

Code Compliance Drawings are based on DCSM section 2.6 and VT CPSM Chapter 5 requirements for preliminary phase submittals, but there are differences in the two types of submittals due, in part, to the type of procurement. See the description below for the minimum acceptable requirements.

2.3.1.1.1 Title Sheet and Building Code Data

1. Project Identification: University, Project Code Number, Appropriation Act Title
2. Index of drawings
3. Applicable building code (Part I or II, and which edition) including referenced documents
4. Applicable accessibility standards
5. Statement of compliance with VT CAC
6. Design occupant loads in accord with VCC for each room and space
7. Building (use) groups -separated or non-separated
8. Building construction type
9. Building height and area
10. Number of stories
11. Tabulation of number of units: bedrooms, sleeping units, fixed assembly seats, parking spaces including accessible units by type
12. Tabulation of the minimum required number of plumbing fixtures, itemized by use group and gender
13. Type of fire suppression system
14. Type of fire alarm system
15. Type of smoke control or smoke removal system

16. State if building is a designated “Emergency Shelter.” Refer to VCC section 1604.5.

17. Seismic design category

2.3.1.1.2 Code Compliance Summary Plans

Provide one summary plan for each floor.

2.3.1.1.3 Summary Floor Plans

1. North arrow and drawing scale (minimum 1/8" scale preferred for floor plans.)
2. Identify all spaces with names and numbers. Show the VCC number of occupants in each room and space, and provide a total number of occupants for each use group. State the calculation method used to determine the number of persons for each room or space, based on its function. The higher number by calculation or actual shall be used.
3. Indicate type and extent of fire protection sprinkler system and fire detection/fire alarm systems on the floor plans.
4. Tabulation of square footage per floor and total building area including new square footage, existing square footage to be renovated, other existing square footage, and total building volume (cubic feet).
5. Indicate paths of means of egress, paths of exit access, travel distances and common paths of travel. Indicate specific locations where access controls or security locking systems will be provided within means of egress paths.
6. For projects that will have partial or phased occupancy, indicate locations and construction of temporary barriers, fire resistance ratings of temporary barriers, locations of temporary exit signage, locations of temporary means of egress emergency lighting and the temporary exit access patterns at each floor for each substantially completed phase.
7. Completely show the continuity of vertical fire resistance rated assemblies, with reference symbols. Distinguish new walls from existing walls and new construction from existing construction.
8. Identify the extent of horizontal fire-rated floor/ceiling and roof/ceiling assemblies, with reference symbols.
9. Provide drawings that clearly define the locations and extent of the application of applied fire resistant materials.

10. Define the UL design assemblies specific to the respective locations and application of applied fire resistant materials.
11. Indicate whether the building is designated as an “essential facility” for purposes of compliance with seismic and snow provisions in VCC Chapter 16.
12. Indicate the seismic design category.
13. Calculations in support of the indicated Construction Type, based on Group, allowable height and allowable area, and permitted or required height and area modifications.
14. Calculations to demonstrate and support the indicated capacity of the egress components throughout the building.
15. Show the location of the water flow test.
16. Identify all required exits and exit discharge.
17. Show locations of fire command center, fire pump room, and generator as applicable.
18. Indicate the accessible routes of travel to the public way.
19. The floor plan shall note by use of the international accessible symbol which restrooms, stalls, and common use areas including kitchens, labs, lounges, laundry rooms, and common work areas are designed for accessible use and for people with disabilities. Clearance rectangles and circles can be utilized to demonstrate necessary clearances.

2.3.1.1.4 Demolition Plans

2.3.1.1.4.1 Interior demolition

1. Provide information on work to be removed
2. Provide asbestos abatement disclosure statement
3. Provide lead disclosure statement

2.3.1.1.4.2 Total building demolition

1. Provide a floor plan showing building size
2. Describe existing material /construction to be removed
3. Show an elevation (drawn or photographic) of building
4. Provide asbestos abatement disclosure statement
5. Provide lead disclosure statement

2.3.1.1.5 Architectural Plans

1. Plans of each floor at $\frac{1}{8}$ " = 1'-0" minimum
2. Show north arrow and scale.

3. Overall building dimensions
4. Room or space names and numbers as provided by VT
5. If the work is an addition, show the relationship of new to existing spaces.
6. Graphically distinguish new from existing construction.
7. Indicate all openings, entrances, delivery areas.
8. Identify the construction materials or systems for floors and walls.
9. Interior and exterior dimensions as needed to demonstrate accessibility

2.3.1.1.6 Roof Plan

1. Roof material; roof slope; location of roof drainage – including primary and secondary drainage
2. Locations of rooftop equipment
3. Significant penetrations and structures
4. Roof access

2.3.1.1.7 Exterior Elevations

1. Scale $\frac{1}{8}$ " = 1'-0" minimum
2. Proposed materials for the foundations; walls and roofs
3. Finished floor elevations and floor-to-floor dimensions
4. Overall building height dimensions from finished grade at face of building wall

2.3.1.1.8 Transverse and Longitudinal Building Sections

1. Scale $\frac{1}{16}$ " = 1'-0" minimum
2. Finished floor elevations; overall and floor-to-floor dimensions
3. Indicate ceilings in relation to floors.
4. Method and extent of insulating exterior envelope.
5. Identify the continuity of the fire resistive construction – horizontally and vertically, including the hourly rating of supporting structure to the ground.

2.3.1.1.9 Civil Plans

The exterior accessible route shall be shown on the site plan. This would include the route from the accessible parking area to the curb cut, sidewalk and entry(s) to the facility. The slope of route shall be noted where applicable.

For capital projects, include information showing the existing and proposed traffic pathways for pedestrians, ADA, vehicles, and any other relevant modes of transportation on the plan sheets for all phases of design. The information should be at a scale at least twice the scale of the disturbed area. Show proposed staging areas.

See the VTAS&S for civil plan requirements.

2.3.1.1.10 Structural Drawings

1. Show occupancy category, live loads, snow loads, wind loads, and seismic criteria used for structural design
2. Show design bearing capacity (soil bearing, pile capacity, caisson capacity) for foundation system
3. Foundation plan indicating type and tentative sizes.
4. Provide north arrow and scale: $\frac{1}{8}$ " = 1'-0" minimum.
5. Foundation details of improved bearing strata and other special requirements.
6. Floor framing plans of each level indicating type of system and tentative member sizes/depths and column spacing.
7. Roof framing plan.
8. Typical sections of framing, identifying materials, thicknesses, depths.
9. Typical section of floor system
10. Details of connections to existing buildings.
11. Identify elements of proposed lateral force resisting system.

2.3.1.1.11 Fire Detection and Alarm Systems – Floor Plans

Show the locations of, and identify, the following:

1. Fire alarm system alarm initiating and notification appliances.
2. Fire alarm control and trouble signaling equipment.
3. Existing alarm system alarm initiating and notification appliances.
4. Existing alarm control and trouble signaling equipment.

2.3.1.1.12 Fire Suppression Systems – Drawings

1. Identify the occupancy hazard classifications and show the locations of sprinklers for the most hydraulically demanding zones within the building for each fire sprinkler system.

2. Show the location of fire department valves and risers within the building, including connections to standpipe risers, combined standpipe and sprinkler riser, or wet pipe sprinkler system risers.
3. Show proposed sprinkler piping and standpipe layout including the main sprinkler lines.
4. Show layout of branch lines for the most hydraulically demanding zones within the building for each system, and size the pipes.
5. Show the locations of water hydrants, test and flow hydrants for water flow tests, and location of underground pipe.
6. Indicate the water flow tests results, the date and time taken and responsible party.
7. Show the water supply flow and pressure at a reference point common with the sprinkler and standpipe design.
8. Clean agent: Identify the rooms to be protected by this system; show the enclosure partitions of the protected area.
9. Clean agent: Identify the locations of the major components of the system; show the general routing of lines from the stored agent and spaces to be protected.
10. Clean agent: Provide a riser diagram defining the clean agent storage tanks, accessories, automatic detection system, alarm devices, manual means of releasing the agent, controlling devices, other pertinent information.
11. Show and clearly identify all existing fire suppression systems.

2.3.1.1.13 Sprayed-on Fire Proofing

Show the proposed UL design assemblies specific to the building structural elements.

2.3.1.1.14 Fire Pumps

1. Show the location of the fire pump, pressure maintenance pump and pump controllers.
2. Show and identify the sprinkler systems and standpipe systems in the vicinity of the fire pumps.
3. Locate the fire department connections and piping to the pump.
4. Locate the fire pump test header and interconnecting piping.
5. Show the location of the system electrical components.

2.3.1.1.15 Mechanical (HVAC) Drawings

1. North arrow and drawing scale: 1/8" scale minimum for floor plans.

2. Show equipment layout, ventilation, condensate disposal.
3. Show routes of duct and exhaust systems.
4. Identify combustion air.
2. Show appliance vents.
3. Show locations of fire and smoke dampers.
4. Indicate locations and tentative sizes of fans, pumps, compressors, conveyors, etc.
5. Description of required smoke control systems, including airflow schematic and sequence of operations.
6. Special equipment: Identify pressure vessels, refrigeration equipment. Show piping layouts.
7. Schematic layout and elevation of equipment room and central system, showing configuration, tie-ins and relevant details.
8. Central heating or cooling plant: show distribution piping and equipment.

2.3.1.1.16 Plumbing Drawings

1. North arrow and drawing scale: 1/8" scale minimum for floor plans.
2. Show fixture locations, types and a tentative schedule.
3. Show routing of main supply and distribution lines, with tentative sizes. Include drainage and venting.
4. Locate water, sanitary sewer, storm sewer and sprinkler services into the building.
5. Show location, sizes and types of hot water heaters, heat exchangers, storage tanks, flues.
6. Show gas piping layout and connected load.
7. Special requirements: Locate special plumbing wastes, traps and interceptors, medical gases.

2.3.1.1.17 Electrical Drawings

1. Power and lighting plans may be combined for this submittal if document clearly conveys the required information.
2. Include north arrow and drawing scale: 1/8" scale minimum for floor plans.
3. Lighting plans for each floor showing approximate fixture location, type, and lighting level required in each room or space, in foot-candles.

4. Power distribution plans showing location of incoming service, generators, and panelboards. Include generator annunciator panel, smoke control system panel as applicable
5. Exit signs and means of egress lighting, interior and exterior.
6. One line riser diagram for the electric service equipment and major distribution components.

2.3.1.2 Code Compliance Narrative

The UBO/SID may waive the requirement for this narrative based on the size and scope of the project. Coordinate with the VT PM.

Provide a narrative that includes the following:

1. Describe the functions to be housed in the building and the applicable VCC Group classification(s).
2. Provide analysis of the VCC and referenced standards requirements of all occupancies in the building.
3. Determine occupancy classifications and compute occupant load, number of exits and other requirements.
4. Calculate the minimum number of plumbing fixtures of each type required, based on the VCC occupancy load. Itemize by use group and gender.
5. Describe unusual or critical code requirements and describe how such requirements will be met.
6. State the VCC construction type (as defined in the current VCC). Describe construction systems and materials proposed to achieve the construction type and fire resistance rating.
7. Compute gross floor area in accord with DCSM section 1.7.3.11. Show calculations used to derive the building efficiency ratio.
8. State the types of thermal insulation proposed, where the insulation is required, and the U or R value for the various portions of the structure.
9. Describe the design features proposed to make the facility conform to the applicable accessibility standard. Universal design that incorporates access for all persons shall be included in the initial planning of all new facilities and shall be clearly presented in the design documents.

2.3.1.2.1 Asbestos, Lead-Based Paint and Hazardous Materials

The A/E shall include a statement addressing the presence of, or potential presence of, asbestos, lead-based paint, and other hazardous materials on the project. Indicate if the University has secured hazardous materials investigation of the project for renovation projects. See DCSM

section 1.7.4.2.2 for the Asbestos Disclosure Statement and DCSM section 1.7.4.3.2 for the Lead Materials Disclosure Statement for appropriate statement to include.

2.3.1.2.2 Structural

1. Describe foundation conditions; type of foundation proposed; maximum allowable bearing capacity for the foundations, and the method by which the allowable bearing values are to be determined.
2. Indicate type of construction adopted; list of materials selected with design strengths and ASTM, AISC, ACI, or other standards to be specified.
3. Describe special features and considerations that affect the design and may not be evident on the drawings.
4. List structural floor and roof systems proposed, including length, spacing and size of principal members.
5. Describe the proposed Lateral Force Resisting System.
6. List live loading data (including floor loads and wind, snow, and seismic loads) as required by the building code.

2.3.1.2.3 Civil

See the VTAS&S for civil narrative requirements.

2.3.1.2.4 Plumbing

1. Describe systems to be utilized on each part of the project.
2. Plumbing fixtures: based on the minimum number of fixtures required, as calculated above, estimate the number of fixture units and water demand in GPM for all plumbing fixtures; describe the types and quality of fixtures.
3. Estimate the maximum and minimum water pressure at each building and indicate if booster pumping will be required.
4. Domestic water heater and distribution system: types, size and design temperature; indicate if heat recovery will be used.
5. Specify materials for each piping system.

2.3.1.2.5 Heating, Ventilation and Air Conditioning

1. Design Conditions: Describe the indoor and outdoor design conditions to be used in the design of the systems for this project. Energy sources for heating and cooling systems shall comply with the VT CAC and DCSM.

2. Heating:
 - a. Describe the source of heat energy to be used, and explain why this source was selected instead of other available sources. Describe the type and routing of the proposed system to convey the heat source.
 - b. State if a condensate return system is to be utilized; if condensate is to be wasted, heat reclaim shall be studied. Indicate maximum hourly production of condensate.
 - c. Describe the type of heating medium and system; describe the HVAC control system.
3. Ventilation:
 - a. Indicate the quantity of outside air per person in all areas, and the type of filtration.
 - b. State if smoke removal or smoke control systems are to be employed.
4. Air Conditioning:
 - a. Provide a description and schematics of the air conditioning system. Indicate locations of major components of the system.
 - b. Define the areas to be air conditioned.
5. Briefly describe the controls for each system and the intended sequence of operation.
6. Briefly describe testing and balancing requirements that will be specified.

2.3.1.2.6 Environmental Pollution Control

Identify expected environmental pollution and the proposed method of control. A detailed description will be necessary for those facilities directly related to controlling air and water pollution such as sewage treatment plants, industrial treatment facilities, incinerators, smoke elimination facilities, and other similar project. When subsurface tile filtration is being considered for sewage disposal, a soil percolation test will be required for each such disposal system. List all environmental control permits and notifications required.

2.3.1.2.7 Special Mechanical Systems

Describe any special mechanical systems, for example, compressed air, hydraulic, and nitrogen, including the source of the medium.

2.3.1.2.8 Central Heating Plants and Heating Plant Additions

1. Describe new boilers, including rating, flow, temperature, pressure and type.
2. Describe control systems.
3. Describe any new auxiliaries to be added and the source of power for their operation.

2.3.1.2.9 Refrigeration (Cold Storage)

1. Identify refrigerated areas, their uses and the temperatures to be maintained.
2. Describe the type of refrigeration equipment and systems.
3. Include preliminary cooling profile, equipment and tank sizes.

2.3.1.2.10 Thermal Storage

Describe the type (static or dynamic) of storage proposed.

Provide preliminary cooling profile, equipment and tank sizes.

2.3.1.2.11 Fire Suppression Systems

1. Describe the types of automatic sprinkler and gaseous extinguishing systems proposed, and note the locations to be protected.
2. Identify the Occupancy Hazard Classifications within the building for each fire sprinkler system, based on the VCC, NFPA 13 and the user's programmatic requirements.
3. Provide a table summarizing the characteristics of each of the sprinkler systems to be provided. List types of systems, areas of coverage, hazard. For each area: list the minimum rate of water coverage; water required; hose stream allowances; total water requirements; hydraulically calculated pressure requirements at a common reference point at design flow; and water supply (flow and pressure) available at the common reference point.
4. Document the water supply available at the point of connection – static pressure and residual pressure at design flow. This data must be based upon flow tests at or near the point of connection.
5. Describe the fire pump operating parameters, components and their operation.
6. Provide preliminary hydraulic calculations to show that the most hydraulically demanding zones of the fire sprinkler systems will be code compliant using the automatic water supply (water supply plus fire pump.)

7. Where the height of the structure is beyond the capacity of fire department apparatus, provide hydraulic calculations to show that the performance of the standpipe system, as connected to the automatic water supply (water supply plus fire pump), will be code compliant.
8. Clean agent system: Identify the types of systems to be used. Provide a preliminary sequence of operations (step-by-step description) for the alarm, notification, control and release of the system. Define the Acceptance Testing requirements.
9. Clean agent system: Provide preliminary calculations to define the enclosure volume and quantity of agent required.

2.3.1.2.12 Fire Alarm Systems

1. Describe fire detection and alarm systems including location of detectors, manual stations, audible devices, control panels and other components.
2. Indicate the type and adequacy of signal and fire alarm systems, including spare capacity on fire alarm circuit.
3. The importance of early resolution of fire protection requirements cannot be overemphasized.

2.3.1.2.13 Electrical Systems

1. Interior distribution systems:
 - a. Electrical characteristics: phase, voltage, number of conductors in main distribution circuits.
 - b. Provide a breakdown in tabular form of the estimated connected load to show lighting loads, convenience outlet loads, power load for building equipment such as heating and air conditioning, and loading for special operating equipment.
 - c. List type of wiring system and where they will be used. NEC prohibits embedding aluminum conduit in concrete without approved supplementary corrosion protection. Design shall ensure that conduit, pipe, bars, anchors or other aluminum parts are not embedded in concrete unless protected.
 - d. Describe type of conductors and where they will be used.
 - e. Include a statement describing proposed pertinent standards of design, such as voltage drop (include calculations), lighting intensities (include calculations), type of lighting fixtures, and use of selective switching or other energy conserving features.

- f. Determination of short-circuit duty required for all service entrance protective devices and switchgear.
 - g. Interface provision for multi-use systems, such as telephone, intercom, data. The University is responsible for design and procurement of telephone and data systems.
2. Outside distribution systems:
- a. Contact utility companies for location and characteristics of nearest service facility capable of meeting project supply requirements. If primary supply at the point of take-off is inadequate for the project, state the measures proposed to correct the deficiency.
 - b. State the electrical characteristics of power supply to the site, including circuit interrupting requirements and voltage regulation.
 - c. Estimate the total connected load and resulting kilowatt demand load.
 - d. State the basis for selection of primary and secondary distribution voltage.
 - e. List the type of conductors, and locations for use.

2.3.1.2.14 Security and Entry Control Systems

Provide a statement of security requirements.

Describe access control equipment and intrusion detection systems.

Outline when and where the systems will be required; note the locations, functions and areas of control.

2.3.2 Landscape Architecture Drawings

Drawings shall include all plans required by the Campus Landscape Architect. Not every drawing plan type is required for all submittals; see requirements below and in DCSM sections 2.5, 2.6, and 2.7.

Drawings must contain plan scale and north arrow and project limit of disturbance (limit of work), other applicable boundaries with survey computations, and existing contours. All of the following plans (except for the Planting Plan) can be located in either Civil or Landscape Plan sets, but should not be located in both.

2.3.2.1 Existing Conditions Plan

Existing pavement, vegetation (including trees labeled with species and caliper size), fixed vertical elements (lighting, trash, benches, etc.), site contours and spot elevations, existing utilities (storm drains, sanitary

sewers, water distribution, fuel gas distribution, fiber optics, building utility distribution pipes and tunnels, electrical, hydrant locations, and data on fire flow tests, etc.), existing building perimeter, entrances, and finished floor elevations. This drawing type is required for all drawing submittals.

2.3.2.2 Demolition Plan

Items to be demolished (structures, walks, utilities, trees, etc.) and items to be protected during construction. Include the Limit-of-Work delineation. Plans should coordinate details associated with demolition plan. See the VT Design Standard Detail Library for applicable details (e.g., the tree protection detail). This drawing type is required for all drawing submittals.

2.3.2.3 Layout Plan

Dimensioned relationship of new work to boundaries and existing structures. Show tree protection fences, Limit-of-Work delineation, and lighting fixtures. This drawing type is required for Preliminary Design and Working Drawing submittals.

2.3.2.4 Accessibility Plan

Pedestrian circulation, including accessible routes, which should identify on- and off-site pedestrian destination points, major pedestrian traffic generators, future facilities, etc., to ensure that proposed walks will address future pedestrian movements. This plan should also contain emergency access routes, and location and quantities of general and accessible parking spaces (if any). Map accessibility routes through each phase of construction. Drawing shall include tree protection fences and Limit-of-Work delineation. The Signage Plan can be combined with Accessibility Plan if it can be clearly expressed. This drawing type is required for Preliminary Design and Working Drawing submittals.

2.3.2.5 Scoring Plan

Detail layout of scoring patterns in all paved surfaces. This can be combined with the Layout Plan if it can be clearly expressed. This drawing type is required for Preliminary Design and Working Drawing submittals.

2.3.2.6 Materials Plan

Contains location and callouts for all hardscape (paving, curbs, walls, steps, etc.) and fixtures/furniture (handrails, guardrails, bike racks, trash and recycling, etc.). Include tree protection fences, Limit-of-Work delineation,

heavy-duty and light-duty paving, fire truck access routes, paving type, walls, curbs, mulched landscape beds, lawn, gravel/river rock, handrails, guardrails, steps, and lighting plan, etc. All hardscape materials should be delivered for approval. Submit a photometric plan illustrating Kelvins and luminaries before the lighting design; this plan shall be provided before the lighting design will be approved. This drawing type is required for Preliminary Design and Working Drawing submittals.

2.3.2.7 Wayfinding/Signage Plan

Contains location and identity for all exterior signage requirements (pedestrian wayfinding, building identification, parking information, etc.). This can be combined with the Accessibility Plan if it can be clearly expressed. This drawing type is required for Preliminary Design and Working Drawing submittals.

2.3.2.8 Grading Plan

Contains new and existing elevation contours affected by new work, also spot elevations showing positive drainage towards stormwater facilities and detailing top and bottom of wall, stair, ramp, etc. Indicate slopes, especially in lawn areas and pathways of travel. Include spot elevations for rim elevations at drainage inlets, low points, and high points. Indicate swales and demonstrate how regraded contour lines tie-in to existing contours at gentle angles. Drawing shall include tree protection fences and Limit-of-Work delineation. Finished floor elevations shall be noted. This drawing type is required for Preliminary Design and Working Drawing submittals.

2.3.2.9 Planting Plan

Contains location, size, and layout of all proposed plant materials. Include soil testing locations. Soil testing report must be provided to the Campus Landscape Architect before the proposed plant list may be approved. Drawing shall include tree protection fences and Limit-of-Work delineation. The soil testing report shall include a soil report which includes sample locations, soil analysis (e.g., pH, compaction, and soil composition), and soil amendment recommendations.

This drawing type is required for all drawing submittals.

2.3.2.10 Planting Schedule

Contains at a minimum, species (Latin and common names), variety/cultivar (if any), size, condition (container-grown, balled and burlap, bare root, etc.),

spacings, and notes pertaining to installation. This can be combined with the Planting Plan if it can be clearly expressed. This drawing type is required for Preliminary Design and Working Drawing submittals.

2.3.2.11 Site Details

Detailed drawings for site elements depicted shall be expressed in this section of the Landscape Architecture drawing set. This drawing type is required for Preliminary Design and Working Drawing submittals.

2.3.3 Professional Seals

All drawings and specifications submitted in support of application for a building permit shall bear the Virginia professional seal(s) of the individual(s) responsible for its design. Schematic and preliminary phase documents are not required to display professional seals. Working drawings are required to display professional seals of the individual design disciplines. Final documents are required to display signed and dated professional seals. Work that is not regulated by the Virginia Department of Professional and Occupational Regulation (DPOR) does not require professional seals.

2.3.3.1 Use of Electronic Seal, Signature and Date

The *Code of Virginia* § 59.1-42.1, Uniform Electronic Transactions Act, regulates the use of electronic records, signatures and contracts. In accord with the Virginia Administrative Code (VAC) § 18VAC10-20-760 – Board for Architects, Professional Engineers, Land Surveyors, Certified Interior Designers and Landscape Architects Regulations – Use of seal: an electronic seal, signature and date may be used in place of an original seal, signature and date when it is a unique identification of the professional, is verifiable and its use is under the professional’s direct control. The electronic seal shall be 2 inches in diameter, meeting all criteria of the regulations referenced above. The printed name shall appear above the license number and both shall be legible. An electronic signature, which may contain digital signature verification, is acceptable as long as all relevant text is legible.

2.3.4 Units of Measurement for Dimensions

All dimensions on drawings shall be expressed in feet, inches and fractions of inches. Metric dimensions are not acceptable.

2.3.5 Size and Weight of Drawings

Drawing sheet size, except in special cases approved by the UBO, shall be 24" × 36" (preferred) or, alternatively, 22" × 34" or 30" × 42". Sheet sizes of 11" × 17" are acceptable with prior approval by the VT PM. Large sets of drawings shall be organized in volumes such that the weight of any volume does not exceed approximately 30 pounds.

2.3.6 Size of Lettering

Mechanical (CADD, BIM) lettering shall be 1/10" minimum and in all caps. The minimum height for hand lettering on all projects shall be 1/8". Spacing between lines shall be equal to one-half the letter height.

2.3.7 Orientation

It is customary for a building plan to be oriented with the main entrance toward the bottom or right edge of the sheet, depending upon the building shape. All plans shall have a North Arrow for orientation. All discipline building plans shall be consistent in orientation insofar as practicable.

2.3.8 Section and Detail Designation

The standard section symbol below is representative of the information required for section and detail "tags." The symbol used on the drawing sheet(s) shall indicate where the section or detail is taken and the drawing sheet where the section or detail is drawn.

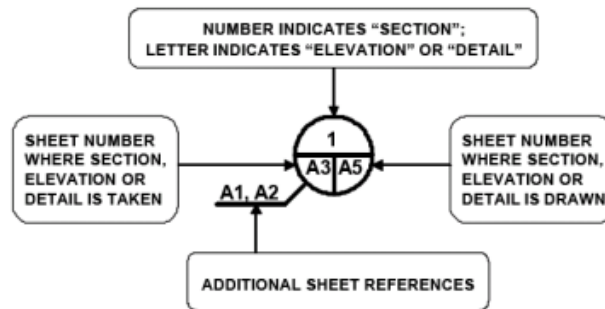

STANDARD SECTION, ELEVATION OR DETAIL SYMBOL

NOTE: SYMBOL SHOULD ALWAYS APPEAR AS PART OF TITLE, PLACED UNDER THE VIEW

2.3.9 Limits of the Work

The drawings shall describe/show the work to be provided by the Contractor. Existing features, structures, or improvements to remain shall be so noted. Existing features, structures, or improvements to be demolished and/or

removed shall be noted or identified. Work, improvements, demolition or construction which the University will perform or have performed by separate contract shall be identified as “Not in Contract” or “NIC” if the abbreviation has been defined.

2.3.10 Date of Construction Documents

All drawings and the specifications shall be dated with the same date which is established by the A/E as the date the documents are (or will be) complete, sealed and ready for bid. Documents printed for bidding shall bear the date described above with no revision numbers or dates and no revision bubbles or clouds.

2.3.11 Determination of Building Area

The building area shall be indicated on the drawings based upon the context of its usage as described below.

2.3.11.1 Building Area for Code Compliance

The square footage provided shall reflect the VCC definition of “Building Area” when determining compliance with VCC Table 506.2 – Allowable Area Factor (At = NS, S1, S13R, or SM, as applicable) in Square Feet.

2.3.11.2 Gross Building Area for CO Forms and Cost Estimates

The square footage provided shall be determined utilizing the guidelines on form DGS-30-219, Area Calculation for Gross Building Area for CO Forms and Cost Estimates. This calculation includes items not included in the VCC “Building Area” such as exterior walls, mechanical penthouses, mezzanines, balconies, and other areas that contribute to the overall building size and scope for the purposes of determining HECO-2 square footage, estimates, or other forms related to the capital outlay process.

2.3.12 Tabulation of Units

Indicate the number of beds (dormitory or hospital), fixed seats (auditorium) or parking spaces (parking deck), and other information relating to capacity of the facility as applicable.

2.3.13 Abbreviations

Provide a master listing of all applicable abbreviations and symbols used in the set of drawings or provide a listing of the discipline-specific abbreviations and symbols at the beginning of each discipline.

2.3.14 Scale of Drawings

Each drawing shall, as a minimum, have a graphic scale shown for the predominant scale used on that sheet. Minimum required scales are given in the following table.

Plans	Description	Scale Required
Foundation and Floor	show all necessary dimensions	minimum of 1/8" = 1'-0"
Roof	preferred scale	1/8" = 1'-0"
a. Roof	without mechanical equipment	1/16" = 1'-0"
b. Roof	metal/shingled pitched	1/16" = 1'-0"
Elevations		1/8" = 1'-0"
Walls	typical wall sections	minimum of 3/4" = 1'-0"
Details		
a. Window, Door, and Special Opening	typical openings	1½" = 1'-0"
b. Interior and Exterior	include special doors, windows, woodwork, paneling or other decorative work, toilets, washrooms, etc.	1/4" = 1'-0"
c. Construction		minimum of 3/4" = 1'-0"
Mechanical and Electrical Rooms		minimum of 1/4" = 1'-0"

2.3.15 Asbestos Project Design

Asbestos drawings and specifications shall have the name, signature and Virginia license number of the asbestos project designer shown on each asbestos drawing sheet and at the beginning of the asbestos specifications section.

2.4 COMPUTER-AIDED DESIGN (CAD) STANDARDS

These standards are issued to promote the development of AutoCAD® drawings suitable for use in the Virginia Tech. Consistency and compatibility with existing Virginia Tech AutoCAD® documents can only be achieved when these standards are strictly adhered to. Electronic drawings produced and submitted in accordance with these standards have significantly greater value to the University, Architects, Engineers, and Contractors delivering AutoCAD® documentation to Virginia Tech. Other Virginia Tech contracts or construction guidelines may reference this section of the DCSM.

All design, construction, and record drawings submitted to Virginia Tech shall follow the DCSM. Primary A/E firms shall enforce these standards with their sub A/E

firms. Each of the following sections contains the most essential criteria for developing AutoCAD® drawings for use in the Virginia Tech CAD environment.

Depending on the size and scope of the project, AutoCAD® drawings may not be required. Coordinate specific requirements with the VT PM.

2.4.1 Drawing Format

Only the AutoCAD® DWG format and associated PDF files are acceptable.

1. CAD files must be in the current AutoCAD® release version; however, Virginia Tech will accept CAD files in versions up to five years prior to the current AutoCAD® release version if necessary. DWG formats only.
2. Revit® BIM models and associated files in current release or up to five years prior to current version if necessary.
3. DXF and PDF files will not be accepted as a substitution for CAD DWG files.

2.4.2 Drawing Composition

AutoCAD® drawings created outside of Virginia Tech sometimes contain more than one drawing sheet per file. While this may facilitate the production of construction documents, it can impede the archival process, workflow processes, and future project use.

To minimize potential problems:

1. Prior to delivery to Virginia Tech, AutoCAD® files containing multiple drawing sheets shall be broken down into separate drawings containing single sheets.
2. AutoCAD® files submitted to Virginia Tech shall contain only one drawing and one title block per file.
3. All AutoCAD® drawings shall be purged of empty, unused, or non-essential drawing data prior to submittal to Virginia Tech. This includes all unused layers, linetypes, blocks, fonts and entities.
4. AutoCAD® drawings shall not contain any frozen layers. All unused entities on frozen layers should be erased and the empty layers purged.
5. AutoCAD® drawings shall not contain multiple overlaid lines or lines with multiple segments unless the overlaid lines or adjacent line segments are assigned to different layers.
6. Survey data shall be included in the AutoCAD® drawings and placed on the appropriate layers (see DCSM section 2.4.4). Survey data collected and used in designing the project shall be submitted as a text file(s) (e.g., ASCII files).
7. Each drawing file shall be named with the sheet number first, followed by the title that sheet (e.g., “A1.1 Architectural Floor Plan First Floor”).

8. Room numbering must follow the DCSM. See DCSM section 2.4.13.

2.4.3 Title Block Information

All title blocks used in AutoCAD® drawings submitted to Virginia Tech shall contain the following information:

1. Original issue date – this date should not change once the drawing has been issued.
2. Sheet number.
3. Title – description of drawing and location information. Location information should include all building names, building numbers, floor level, and room numbers as applicable.
4. Revision history – as applicable.
5. Drawing phase – drawings submitted as Record Drawings should clearly be marked as such.
6. Virginia Tech Project number- if applicable.
7. A/E/C – Consultant responsible for producing the drawings should be clearly identified.
8. Contractor – Record Drawings should clearly indicate the General Contractor.

2.4.4 Layering Standards

The intent of the layering standard is to promote consistency between CAD drawings, and maximize the reusability of drawing data. The effective use of CAD layering standards also facilitates the grouping of shared graphical information for display, editing and plotting purposes. The Virginia Tech layering standards are based on the National CAD Standards (NCS) and the AIA CAD Standards (AIA), latest edition, Layering Guidelines.

All AutoCAD® drawings submitted to Virginia Tech shall follow the NCS/AIA layering standards.

1. Use the minimum number of layers necessary to adequately separate entities in each drawing. The number of layers contained in each drawing will vary depending on the scope and complexity of the drawing.
2. Purge each drawing of unused layers prior to submittal.

2.4.5 Entity Properties

To ensure the integrity of the original drawing when viewing or printing, it's essential that AutoCAD® entities are created following these standards:

1. Entity colors shall be defined by layer, not by entity.
2. Blocks shall be defined (created) on layer 0 (zero).

3. All attributes shall be defined on layer 0 (zero).

2.4.6 Model and Paper Space Usage

Model Space and Paper Space Combined: Each CAD file is set up to contain only one title block in paper space which references the building model contained in model space. The building model contained in model space is made presentable through the use of a viewport in paper space. This is the acceptable drawing method.

These guidelines are suggested for using model and paper space effectively:

1. Place title blocks, schedules and general notes at full-scale in paper space whenever possible.
2. Do not place or draw model-related blocks, tags and objects in paper space.
3. Draw all model space objects at full scale.
4. Scale objects using paper space viewports; zoom viewports to the appropriate scale.
5. Label scaled viewports with the corresponding scale in model space.

2.4.7 External References – Xrefs

External References (Xrefs) contained in AutoCAD® drawings created outside of Virginia Tech can result in content discrepancies in the submitted drawing set. To ensure the integrity of the drawing set, and minimize potential problems:

1. Bind Xrefs to the drawings before they are submitted to Virginia Tech.
2. AutoCAD® drawings submitted to Virginia Tech shall not contain any attached Xrefs.

2.4.8 Referenced Image Files

Virginia Tech will not accept any referenced images (JPGs, BMPs, PNGs, etc.). All images included in a drawing must be inserted into the drawing as an OLE object.

2.4.9 AutoCAD® Drawing Support Files

Drawings created using non-standard AutoCAD® fonts, linetypes, and hatch patterns can result in content discrepancies and licensing conflicts in the delivered drawing set. To ensure the integrity of the drawing set, and minimize potential problems:

1. Only native AutoCAD® or AutoCAD Land Desktop® fonts, linetypes, and hatch patterns or the CAD symbology provided by the NCS is acceptable.
2. Custom fonts, linetypes, and hatch patterns, including those provided by third party software, are not acceptable.

3. Only these TrueType fonts are acceptable: Arial, Courier New, and Times New Roman.
4. Postscript fonts shall not be used.

2.4.10 File Submittal

The content of electronic drawings provided by the A/E must match the delivered original hard copy set. To ensure the integrity of the electronic drawing set upon delivery to Virginia Tech:

1. Ensure the drawings adhere to the DCSM. Prior to submission, review the procedures for preparing drawings for submittal as detailed in the preceding sections.
2. Include an index containing filenames and sheet numbers for each submittal. This ensures the completeness of the drawing set and assists in archival procedures.
3. Include the CAD Record Documents Submitted form with all submittals indicating Virginia Tech Project number, Virginia Tech Project name (if applicable), and complete listing of all materials submitted. See the VT Design Standard Forms Library for the CAD Record Documents Submitted form.
4. Include all field survey data.
5. Submit copies of original Contractor “red line” plans and specifications.
6. In accordance with the A/E contract, all Record Drawings, including civil and site Record Drawings, must be signed and sealed by a Professional Engineer and clearly marked “Record Drawings”.

2.4.11 Submittal Requirements

The following documentation will be delivered to Virginia Tech at the following project milestones accompanied by the completed CAD Standards Quality Assurance Checklist:

1. Design – Schematic/Preliminary/Working Drawings
Virginia Tech requires a complete set of Review Documents in AutoCAD® DWG and PDF formats. During the preliminary and design phases of the project, various Virginia Tech departments which review the design may use the DWG and PDF files to provide feedback and questions on the design.
2. Bid Documents
AutoCAD® drawings in both DWG and PDF format and all specifications in PDF format shall be submitted to the VT PM for posting prior to the pre-construction meeting or start of the project.

3. CAD Floor Plan Drawings

At construction, the A/E shall submit a CAD floor plan drawing for review. At substantial completion, the A/E shall submit an updated CAD “As-Built” redline drawing for the use in managing the facility. See DCSM section 2.4.12.

4. Record Drawings

The A/E shall submit stamped Record Drawings showing the “As-Built” conditions to Virginia Tech within 30 days of post substantial completion. The documents shall contain the as-built information on the project and shall include all drawings in both DWG and PDF formats and all specifications, manuals, etc., in PDF format.

See the VT Design Standard Forms Library for the CAD Standards Quality Assurance Checklist form.

2.4.12 Floor Plan Standards

This section establishes the technical standards and specifications for the creation of CAD floor plan drawings for Virginia Tech.

2.4.12.1 Scope of Work

1. Provide architectural floor plans for all floor levels.
2. Every room/space in the listed buildings shall be field verified and measured to 0.25" accuracy.
3. For each CAD drawing, for each room, verify the accuracy of the room number as identified on the door or faceplate with the CAD drawings provided by Virginia Tech. If information is not available in any form, the room number shall be identified in the CAD drawing as “no-number”; otherwise, use the known room number.
4. For data and communication closets (telephone closet, data closet, etc.) and mechanical/electrical closets and rooms, only measure and verify space; do not draw equipment in the space.
5. Measuring and survey standards shall follow the *Postsecondary Education Facilities Inventory and Classification Manual (FICM): 2006 Edition* guidelines provided by the U.S. Department of Education, National Center for Education Statistics.
6. All drawings shall be created in model space and drawn to full size (1:1 scale).
7. All entities (e.g., lines, arcs, polylines, and blocks) shall be drawn at elevation (0), have a thickness of (0), have a width of (0), have their color set to “BYLAYER”, and have their line weight set to “BYLAYER”.

8. No duplicate or overlapping lines or arcs shall be used. The “overkill” AutoCAD command may be used to help eliminate any duplicate or overlapping lines and arcs.
9. All submitted CAD drawings shall be DWG files using AutoCAD version 2013 or newer. DXF files will not be accepted as a substitution.
10. No externally referenced data (i.e., Xrefs), non-standard fonts, or other non-standard drawing entities shall be used.
11. All CAD drawings shall be purged of empty, unused, and non-essential drawing data.
12. All blocks used (e.g., doors and plumbing fixtures) shall be created on layer “0” and inserted on their proper layer.
13. The current layer shall be set to “0”.
14. The file naming convention: bbbbSAff.DWG
 Where: bbbb = 4-digit (with leading zeros) building number; may have alpha suffix
 SA = Schematic Architectural
 ff = 2-digit (with leading zeros) floor level number
15. All CAD work submitted to Virginia Tech shall adhere to the DCSM.

2.4.12.2 CAD Drawing Standards

2.4.12.2.1 General Guidelines

1. For all survey tasks – refer to and comply with the FICM guidelines.
2. General description of work: create architectural floor plan drawings.
3. Primary drawing entities are lines and arcs.
 - a. Blocks shall only be used for hinged doors and plumbing fixtures
 - b. Polylines shall only be used on layers “Gross” and “Rooms” for area mapping

2.4.12.2.2 Drawing Standards

1. Walls – lines on layer “FLOOR”, color 7 (White)
 - a. For interior walls, the lines shall be broken and trimmed at each wall intersection and not be continuous through perpendicular or angled walls.
 - b. Phantom walls (lines with linetype of “DASHED” and drawing LTScale of 30) may be used to delineate major room use differences, major hallway direction changes, and other space differentiations.

- c. Phantom walls shall be drawn in doorways with no physical door located at the wall thickness midpoint.
- 2. Identify floor elevation changes (steps, ramps, tiers, etc.) – lines on layer “STAIRS”, color 7 (White); with elevation arrows on layer “TEXT”, color 6 (Magenta)
- 3. Doors – blocks on layer “DOOR”, color 1 (Red)
 - a. Hinged doors – blocks
 - i. Door
 - ii. Swing direction
 - iii. Door size is based upon width of clear opening between door jambs
 - b. Sliding doors – lines
 - i. Door (simple line) slightly offset
 - ii. Door size is based upon width of clear opening
- 4. Windows – single lines on layer “WINDOW”, color 5 (Blue)
 - a. Three lines drawn at the front, middle, and back of wall or frame thickness indicates window glazing is present
 - b. Window size is based upon width of clear opening
- 5. Casework – single lines on layer “CASEWORK”, color 3 (Green)
 - a. Built-in casework resting on the floor (lab benches, fixed counters, etc.) (simple lines)
 - b. Mobile/Movable benches – use “DASHED” linetype
- 6. Plumbing fixtures – blocks on layer “PLUMBING”, color 6 (Magenta) including built-in sinks, toilets, shower stalls, bathtubs, water fountains, etc.
- 7. Toilet partitions – lines on layer “TPART”, color 3 (Green)
- 8. Elevators – lines on layer “ELEVATOR”, color 7 (White). Include elevator carriage on the ELEVATOR layer only, not elevator shaft walls.
- 9. Space identification – text on layer “TEXT”, color 6 (Magenta). For each CAD drawing, for each room, verify the accuracy of the room number as identified on the door or faceplate with the CAD drawings provided by Virginia Tech. If information is not available in any form, the room number shall be identified in the CAD drawing as “no-number”; otherwise, use the known room number.

See DCSM section 2.4.12.4 for Layer Standards.

2.4.12.3 Polylines Drafting Standards

2.4.12.3.1 Rules for Drafting Exterior Gross Polylines

1. The exterior gross polylines shall be drawn to the exterior surface of the exterior wall of the building.
2. The exterior gross polylines must not include patios, exterior stairs, or roof areas.
3. The exterior gross polylines shall be located on the “Gross” layer and have its width set to (0).
4. All exterior gross polylines must be closed by the use of the “close” <c> command. No other method is allowed.
5. All exterior gross polylines must be drawn in Model Space (not Paper Space).
6. Color 2 – Yellow.

2.4.12.3.2 Rules for Drafting Interior Gross Polylines

1. The interior gross polylines shall be drawn to the interior surface of the exterior wall of the building including attached columns.
2. The interior gross polylines shall be located on the “Gross” layer and have its width set to (0).
3. All interior gross polylines must be closed by the use of the “close” <c> command. No other method is allowed.
4. All interior gross polylines must be drawn in Model Space (not Paper Space).
5. Color 2 – Yellow.

2.4.12.3.3 Rules for Drafting Room Polylines

1. The room polylines shall be drawn to the interior wall surface of each room/space. In the case of an elevator, the polylines shall be drawn to the surface of the interior wall, not to the surface of the elevator carriage.
2. All spaces (rooms, chases, corridors, bathrooms, kitchens, lobbies, closets, etc.) shall have a room polyline.
3. The room polylines shall not include any door threshold areas for entrances with doors.
4. The room polylines shall include one-half of any door threshold areas for entrances without doors so that the threshold is completely accounted for by the two adjacent room polylines.

5. The room polylines shall be located on the “Rooms” layer and have its width set to (0).
6. All room polylines must be closed by the use of the “close” <c> command.
7. All room polylines must be drawn in Model Space (not Paper Space).
8. Color 3 – Green.

2.4.12.4 Layer Standards

FLOORDWG Layer Properties:

Name	Color	Linetype	Lineweight	Plot Style	Description
0	15	CONTINUOUS	Default	Color_15	
CASEWORK	green	CONTINUOUS	Default	Color_3	Built-in floor casework including lab benches and counters; lines
DOOR	red	CONTINUOUS	Default	Color_1	Doors; blocks of single line and arc showing door swing
ELEVATOR	white	CONTINUOUS	Default	Color_7	Elevator carriage; lines
FLOOR	white	CONTINUOUS	Default	Color_7	Walls; lines, arcs, and circles
PLUMBING	magenta	CONTINUOUS	Default	Color_6	Plumbing Fixtures including toilets, sinks, etc.; blocks
STAIRS	white	CONTINUOUS	Default	Color_7	Stairs; lines
TEXT	magenta	CONTINUOUS	Default	Color_6	Text – room numbers are 1'3"; stair directions (UP/DN) are 1'0"; centered as possible (Text angles are either 0 degrees or 90 degrees; style is "STANDARD"; font is "simplex") Directional arrows – arrow points are lines 1'0" long and 45 degree angle from shaft line
TPART	green	CONTINUOUS	Default	Color_3	Toilet partitions; lines
WINDOW	blue	CONTINUOUS	Default	Color_5	Windows; lines
Rooms	green	CONTINUOUS	Default	Color_3	Closed polylines: one for each interior space
Gross	yellow	CONTINUOUS	Default	Color_2	Two closed polylines: 1) Exterior gross area; 2) Interior gross area These two polylines border the exterior wall(s) of the building

2.4.12.5 Quality Assurance/Quality Control (QA/QC)

Virginia Tech will check rooms and floors for drawing and tabular data accuracy. If delivered data/floor plans do not meet accuracy standards per

Virginia Tech QA/QC, Contractor agrees to update drawings/deliverables as needed at no additional charge.

2.4.13 Room Numbering Standards

2.4.13.1 Goals

1. Identify rooms for visitors to the building so they may be easily located in a systematic way.
2. Identify rooms for building occupants.
3. Identify rooms for administrative identification (NI&S, Physical Plant, 911, etc.) and databases.

2.4.13.2 Room Numbering Guidelines

1. Coordinate project specific room numbering reviews as part of the Schematic Design with VT PM.
2. The same room numbering sequence should be used on all floors of the same building with lower room numbers at one end of the building and higher room numbers at the other end of the building. Also, even room numbers should be on one side of the primary hallway and odd room numbers on the other side as possible.
3. Rooms in similar locations on different floors should have similar room numbers so that room numbers are coordinated on a vertical basis as well as a horizontal basis in the entire building. For example, rooms 115, 215, and 315 should all be located directly above or below each other or as close as possible. If room numbers in the building are 4-digit numbers, then follow the same room numbering sequence.
4. Reasonably allow for renovation changes. Rooms should be numbered in such a manner that, should renovations occur in the future, intervening numbers will be available for room assignments (especially where larger rooms are built that may be subdivided into smaller rooms at some time in the future).
5. All accessible spaces must be assigned a room number. If an area of a room has a different use function or is not clearly delineated by walls and doors (for example, an area off a corridor that is used for a work area), dashed lines should be added to the floor plan to clearly identify the space and it should be identified by a room number.
6. All assignable rooms (including offices, labs, classrooms, conference rooms) should have their room number begin with a numeric character; the first digit specifies the floor number.

7. All non-assignable rooms (including bathrooms, corridors, stairs, elevators, janitor closets, mechanical and electrical rooms) should have their room number begin with an alphabetic character followed by a numeric room number; the first character specifies the floor number with “A” being the first floor, “B” being the second floor, etc.
8. Use 3-digit room numbers unless there are too many rooms on a floor.
9. All interior rooms accessed from a primary room (including suites) have an alphabetic character (“A”, “B”, etc.) following the primary room number. A secondary interior room (e.g., a closet) should have a single digit (“1”, “2”, etc.) following the alphabetic character of the first level interior room. For example, Room “101A1” is accessed from room “101A” that is accessed from room “101”.
10. When renovating a large room to include other rooms, the new interior room(s) will maintain the primary room number followed by an alphabetic character (“A”, “B”, etc.). For example, 1180 (primary) interior rooms would be 1180A, 1180B, 1180C, etc. If room numbers in the building are 4-digit numbers, then follow the same room numbering sequence. The first space of the corridor or other entrance will retain its number.

2.4.13.3 Clarification

1. The A/E typically assigns “space numbers” to identify each space with its properties when designing area. “Space numbers” are usually assigned sequentially without regard to the space layout.
2. “Space numbers” vs. “Room numbers”
 - a. “Space numbers” – are not usually “room numbers.” For example, an area (room) with room number 218 is renovated and divided into several interior spaces. The A/E may identify the interior spaces with “space numbers” 101, 102, 103, etc., that are not related to the existing room or building numbering scheme.
 - b. “Room numbers” – are used to locate rooms within the building as a whole and thus are assigned in a regular and systematic fashion.
3. Contact Space Data for additional information (GIS-Space-g@vt.edu) and coordinate additional requirements with the VT PM.

2.5 SCHEMATIC DESIGN

2.5.1 General Requirements for Capital Projects

Unless waived by the HECO-2 Action Wording, a schematic design/project criteria submittal shall be made to the University for review. The purpose of the

schematic submittal is to further develop data, detail and scope including schematic plans, as well as verify the data and program contained in the Capital Project Request. The project scope established by the schematic design, as agreed to by the University and the A/E shall become a part of the A/E Contract as further definition of the scope described in the Capital Project Request data.

The A/E shall coordinate with UBO and SID early in the Schematic Design phase to ensure compliance with code and University standards.

The schematic submittal shall include an updated/current project scope profile, or a listing of the assignable rooms and spaces, which was used as the basis for development of the schematic design.

All review issues must be resolved before the A/E is authorized to proceed with the preliminary design.

2.5.2 Schematic Submittal Requirements

Submit the following:

1. Basis of Design Narrative

The schematic design shall include a Basis of Design Narrative in accord with DCSM section 2.1.

2. CR-2 Form

For pool projects, a completed CR-2 form shall be submitted as part of the Schematic submittal indicating, in sufficient detail, construction costs (detail provided in A/E estimate), soft costs, delivery method, anticipated bid date, anticipated construction duration, project square footage, and all anticipated project funding sources.

3. A/E Project Cost Estimate

The A/E shall prepare a schematic design estimate in accordance with DCSM section 2.2.

4. Schematic Drawings

a. Title Sheets

- i. Project Identification: University, Project Code Number, Appropriation Act Title
- ii. Activity or function(s) to be performed in the facility
- iii. Edition (year) of the VUSBC on which the design is based.
- iv. Applicable accessibility standards.
- v. VCC Construction Type.
- vi. (Use) Group(s) per VCC. For mixed-use occupancies, indicate which Groups are separated and non-separated.
- vii. Other major code(s) used as a basis for design.

- viii. Statement of compliance with VT CAC including the applicable version of the LEED checklist.
 - ix. Maximum VCC occupancy for each level and total for the building.
 - x. Location and vicinity maps noted to show project location.
 - xi. Tabulation of GSF per floor (new and renovated), total GSF (all floors – new and renovated), total building volume.
 - xii. Tabulation of “Building Area” per VCC definition (per story).
 - xiii. Tabulation of units: Number of parking spaces, auditorium seats, bedrooms, etc.
 - xiv. Building purpose/occupancy.
 - xv. Design occupant load for each level and total for the building.
 - xvi. Occupant load for each level and total for the building.
 - xvii. Index of drawings.
 - xviii. The uniform date of the completed schematic design documents.
- b. Architectural Drawings
- The following drawings shall be included as a minimum:
- i. Architectural Floor plans of each floor showing space names, nominal room sizes, and circulation paths
 - ii. Architectural Roof plan showing roof slopes and drainage
 - iii. Longitudinal building section with floor to floor and floor to ceiling dimensions
 - iv. Transverse building section
 - v. Exterior elevations
 - vi. Structural plan of a typical supported floor framing scheme and a typical section showing the proposed components of the floor system
 - vii. Orientation and approximate location of proposed roads, walks and parking on a site plan
 - viii. The rooms and spaces to be protected by any proposed fire suppression system (including clean agent) and the proposed locations of the major fire suppression system components.
 - ix. Any other information that is of value to the University and the A/E reviewing the project.
- c. Landscape Architecture Drawings (see DCSM section 2.3.2)
- The following drawings shall be included as a minimum:
- i. Existing conditions
 - ii. Site demolition

- iii. Layout and dimensions
- iv. Planting concepts
- d. Fire Protection Information Plan
Provide the following as a minimum:
 - i. Indicate whether or not the building will be equipped with fire protection sprinkler system and/or fire detection/fire alarm systems.
 - ii. Design occupant load(s), including the number of occupants to be accommodated in each space. The determination for the occupants is based on the use and function of the spaces.
 - iii. Indicate paths for means of egress, paths of exit access, travel distances to exits and common paths of travel. Indicate specific locations where access controls or security locking systems will be provided within means of egress paths.
 - iv. Identify projects that will have partial or phased occupancy.
 - v. Indicate fire-resistance rating(s) of all proposed assemblies. Completely show the continuity of the rated assemblies using reference symbols.
- e. Verification of Existing Conditions
The A/E shall visit the site and ascertain pertinent local conditions which must be addressed in the design. As part of the required services, it is the A/E's responsibility to verify, by on-site observations of applicable existing buildings, the configurations, locations, dimensions, sizes and conditions accessible for verification. Certain assumptions are made regarding existing conditions in the remodeling and or rehabilitation of an existing building. Some of these assumptions may not be verifiable without additional exploration or investigation of the building or site. To minimize the risk during construction of uncovering conditions that are not as shown on the documents and delaying project progress, the University should consider and evaluate the advice of the A/E to conduct additional investigation, verifications or checks to verify.

2.6 PRELIMINARY DESIGN

2.6.1 General Requirements for Capital Projects

Based on the previous approvals and direction, the A/E shall prepare the preliminary design consisting of drawings and other documents to fix and describe the size and character of the entire project as to exterior appearance; foundation, structural, mechanical, and electrical system; materials; and such

other essentials as may be appropriate. The A/E shall have visited the site and ascertained pertinent local conditions required to be addressed in the submittal. If any change from the information submitted at the schematic stage relating to the mix or amount of space occurs, the University shall submit new information in the format of an updated/current project scope profile, or a listing of the assignable rooms and spaces which was used as the basis for development of the preliminary design.

The submittal documents along with the review comments and the agreed upon resolutions of the comments shall be the basis of the approval for the A/E to prepare the working drawings.

2.6.2 Preliminary Submittal Requirements

Submit the following:

1. Basis of Design Narrative
2. CR-2 Form (pool projects)
3. A/E Project Cost Estimate.
4. Independent Cost Estimate
5. HVAC Systems Life Cycle Cost and Energy Analysis
6. Fuel Source Life Cycle Cost and Energy Analysis
7. VE Study and recommendations, if applicable
8. Geotechnical Report
9. Calculations
10. Preliminary Drawings
11. Preliminary Specifications

2.6.2.1 Basis of Design Narrative

The narrative shall describe the project scope, the functional and operational criteria to be met, the justification for the decisions or choices made and any proposed deviations from the standards required by DCSM section 2.1.

2.6.2.2 CR-2 Form

For pool projects, a completed CR-2 form shall be submitted as part of the preliminary submittal indicating, in sufficient detail, construction costs (detail provided in A/E and independent cost estimates), soft costs, delivery method, anticipated bid date, construction duration, project area calculated in accord with form DGS-30-219 and all project funding sources.

2.6.2.3 A/E Preliminary Cost Estimate

The A/E shall prepare a preliminary design estimate in accordance with DCSM section 2.2.

2.6.2.4 Independent Preliminary Cost Estimate

The University shall submit an independent preliminary design estimate in accordance with DCSM section 2.2.

2.6.2.5 VE Study

Submit a value engineering study and University recommendations in accord with DCSM section 1.4.2.

2.6.2.6 Geotechnical Report

Submit a geotechnical report that includes boring logs, geotechnical analysis and foundation design recommendations.

2.6.2.7 Calculations

Submit one copy of calculations for each discipline. Indicate design criteria, loadings, assumptions, evaluations and comparisons of alternative systems, cost factors and other considerations which support the systems selected and shown on the drawings. Calculations shall include the HVAC Systems Life Cycle Cost and Energy Analysis and the Fuel Source Life Cycle Cost and Energy Analysis. See DCSM section 1.4.3.

2.6.2.8 General Requirements for Preliminary Drawings

Preliminary drawings shall include the following information unless such information is not applicable to the project:

2.6.2.8.1 Title Sheets

1. Project Identification: University, Project Code Number, Appropriation Act Title.
2. Activity or function(s) to be performed in the facility
3. Edition (year) of the VUSBC on which the design is based.
4. Applicable accessibility standards.
5. VCC Construction Type.
6. (Use) Group(s) per VCC. For mixed-use occupancies, indicate which Groups are separated and non-separated.
7. Other major code(s) used as a basis for design.
8. Asbestos Disclosure Statement and Lead Disclosure Statement.

9. Statement of compliance with the VT CAC.
10. Maximum VCC occupancy for each level and total for the building.
11. Location and vicinity maps noted to show project location.
12. Tabulation of GSF per floor (new and renovated), total GSF (all floors– new and renovated), total building volume.
13. Tabulation of “Building Area” per VCC definition (per story).
14. Building efficiency ratio tabulation.
15. Tabulation of units: Number of parking spaces, auditorium seats, bedrooms, etc.
16. Building purpose/occupancy.
17. Design occupant load for each level and total for the building.
18. Index of drawings.
19. The uniform date of the completed preliminary design documents.

2.6.2.8.2 Site Drawings

Submit a site/improvement plan and composite utility plan for new construction and additions. The site plan shall be based upon an approved comprehensive Master Plan.

1. Plan scale and north arrow.
2. New and existing contour elevations affected by the work.
3. Floor and contour elevations.
4. Applicable boundaries with survey computations.
5. Dimensioned relationship of new work to boundaries and existing structures.
6. Location of test borings.
7. Location and quantities of general and accessible parking spaces.
8. Accessible routes.
9. Pedestrian traffic routes.
10. Fire truck access.
11. Fire department connection location.
12. Items to be demolished: structures, walks, utilities, trees, etc.
13. Proposed landscaping (planting materials). See DCSM section 4.1.
14. Existing and new utilities: storm drainage, sanitary sewers, water distribution, fuel gas distribution, building utility distribution pipes and tunnels, electric and telephone poles and lines, hydrant locations, and data on fire flow test, etc.
15. Site improvements such as fencing, lighting, etc.
16. Typical paving section for proposed types/thicknesses.

17. Identify/show special earthwork recommended and construction considerations noted in geotechnical report.

2.6.2.8.3 Demolition Drawings

For interior demolition:

1. Identify items to be removed;
2. Asbestos Disclosure Statement;
3. Lead Disclosure Statement.

For total building demolition:

1. Floor plans showing building size;
2. Description of existing material /construction to be removed;
3. Elevation (drawn or photographic) of building;
4. Asbestos Disclosure Statement;
5. Lead Disclosure Statement.

2.6.2.8.4 Landscape Architecture Drawings

Include the following drawings. See DCSM section 2.3.2 for drawing requirements.

1. Existing conditions
2. Site demolition
3. Layout and dimensions
4. Accessibility plan
5. Scoring plan
6. Site materials plan
7. Wayfinding/signage plan
8. Grading plan
9. Planting concepts
10. Planting schedule
11. Site details

2.6.2.8.5 Architectural Drawings

1. Floor Plans (for each floor)
 - a. Plans of each floor at $\frac{1}{8}'' = 1'-0''$ scale, minimum
 - b. Overall dimensions
 - c. Space names and numbers
 - d. Relationship of new work to existing spaces
 - e. Distinguish new work from existing construction
 - f. Identification of openings, entrances, delivery areas (including door numbers)

- g. Identification of accessible routes accessible building entrances, and Areas of Refuge
 - h. Calculations to support the indicated design occupant load on a use and function and floor by floor basis. Include the design occupant load for the function of each room and space in accord with VCC section 1004.
 - i. Plan scale and north arrow
2. Roof Plan
- a. Existing and proposed roof drains.
 - b. Means of secondary (emergency) roof drainage
 - c. Indicate direction of roof slope with arrows, high to low: $\frac{1}{4}$ " per 1'-0" minimum to drains (unless waived for reroofing).
 - d. Existing and new equipment.
 - e. Roof penetrations and structures.
 - f. Expansion joints
 - g. Access to roof
 - h. Identify materials of existing roofs and new roofs.
 - i. Fall protection equipment
3. Exterior Elevations (Scale: $\frac{1}{8}$ " = 1'-0" minimum)
- a. Openings: windows (including operable notation), doors, louvers, vents
 - b. Percentage of glass vs. gross wall area (per elevation and/or exposure)
 - c. Floor elevations
 - d. Identification of all major finishes
 - e. Stairs, ramps, and railings
 - f. Rooftop equipment and structures
 - g. Expansion and control joints
 - h. Grade at the face of the building wall
 - i. Subsurface construction (dotted in)
 - j. Distinguish new work from existing construction
4. Building Cross Sections (Scale: $\frac{1}{16}$ " = 1'-0" minimum)
- a. One longitudinal and one transverse section, minimum
 - b. Indication of floor elevations
 - c. Indication of ceilings in relation to floors
 - d. Method and extent of insulation of exterior envelope
5. Wall Sections (Scale: $\frac{3}{4}$ " = 1'-0" minimum)
- a. One section for each type of wall construction
 - b. Identification of materials and components

- c. Identification of insulation type including “R” value
 - d. Identification of air barrier and moisture barrier
6. Finish Schedule
- a. May be included in the Basis of Design narrative or on drawing. Indicate proposed finishes for all spaces. Note those existing finishes to remain.
 - b. Give ceiling heights of interior spaces.

2.6.2.8.6 Furnishing/Equipment Drawings

- 1. Show equipment to approximate scale.
- 2. Show furniture and built-in furnishings to scale.

2.6.2.8.7 Structural Drawings

- 1. Provide Live Loads, Snow Loads, Wind Loads, and Seismic Criteria used for structural design. Refer to VCC Chapter 16.
- 2. Show design bearing/support capacity (soil bearing, pile capacity, caisson capacity) for foundation system.
- 3. Provide the design lateral active and at-rest earth pressures, where applicable.
- 4. Provide Foundation Plan indicating type and tentative sizes.
- 5. Provide Foundation details of improved bearing strata and other special requirements.
- 6. Provide Floor Framing` Plans of each level indicating type of system and tentative member sizes/depths and column spacing.
- 7. Provide Roof Framing Plan.
- 8. Provide Typical Section(s) of framing identifying materials, thicknesses, and depths.
- 9. Provide Typical Section of floor system
- 10. Provide Details of connections to existing buildings, if applicable.
- 11. Identify elements of proposed lateral force resisting system.

2.6.2.8.8 Fire Protection Information Plan and Calculations

Provide the following as a minimum to demonstrate compliance with the code:

- 1. Indicate type and extent of fire protection sprinkler system and fire detection/fire alarm systems on the floor plans.
- 2. Tabulation of square footage per floor and total building area (per VCC definitions) including new square footage, existing square

footage to be renovated, other existing square footage, and total building volume (cubic feet).

3. Indicate paths of means of egress, paths of exit access, travel distances and common paths of travel. Indicate specific locations where access controls or security locking systems will be provided within means of egress paths.
4. For projects that will have partial or phased occupancy, indicate locations and construction of temporary barriers, fire resistance ratings of temporary barriers, locations of temporary exit signage, locations of temporary means of egress emergency lighting and the temporary exit access patterns at each floor for each substantially completed phase.
5. Indicate rating of all fire resistance-rated assemblies, smoke barriers and smoke partitions.
6. Completely show the continuity of vertical fire resistance rated assemblies, with reference symbols. Distinguish new walls from existing walls and new construction from existing construction.
7. Identify the extent of horizontal fire-rated floor/ceiling and roof/ceiling assemblies, with reference symbols.
8. Provide drawings that clearly define the locations and extent of the application of applied fire resistant materials.
9. Define the UL design assemblies specific to the respective locations and application of applied fire resistant materials.
10. Indicate whether the building is designated as an “essential facility” for purposes of compliance with seismic and snow provisions in VCC Chapter 16.
11. Indicate the seismic design category.
12. Calculations in support of the indicated Construction Type, based on Group, allowable height and allowable area, and permitted or required height and area modifications.
13. Calculations to demonstrate and support the indicated capacity of the egress components throughout the building.

2.6.2.8.9 Fire Suppression Systems – Sprinklers/Standpipes

If the project delivery method is one that will require early release packages for phased permitting, refer to specific requirements outlined in DCSM section 2.3.1.

2.6.2.8.10 Fire Suppression Systems – Alternate Automatic Systems

If the project delivery method is one that will require early release packages for phased permitting, refer to specific requirements outlined in DCSM section 2.3.1.

2.6.2.8.11 Fire Pumps

If the project delivery method is one that will require early release packages for phased permitting, refer to specific requirements outlined in DCSM section 2.3.1.

2.6.2.8.12 Fire Detection and Fire Alarm Systems

If the project delivery method is one that will require early release packages for phased permitting, refer to specific requirements outlined in DCSM section 2.3.1.

2.6.2.8.13 Smoke Control Systems

With the submission of preliminary design documents, the A/E shall develop and submit a preliminary “Rational Analysis” (a detailed design report) to the UBO for review and approval. Refer to DCSM section 2.7.7.15.6 for detailed requirements.

2.6.2.8.14 Plumbing Drawings

1. Provide plans of each floor noting fixture locations and types. Indicate routing of main distribution lines with tentative sizes.
2. Provide riser diagrams for all piping systems.
3. Provide location of water supply and distribution, sanitary drainage, storm drainage, and sprinkler services to the building.
4. Provide plumbing fixture schedule.
5. Provide location, sizes and types of water heaters/ heat exchangers, storage tanks, flues, etc.
6. Provide fuel gas piping layout and connected load, if applicable.

2.6.2.8.15 Mechanical (HVAC) Drawings

1. Provide plans of each floor showing single line duct layouts, tentative air (supply, return, exhaust) quantities, equipment locations, and layouts and general routing of heating/cooling piping.
2. Provide equipment schedules with tentative sizes, capacities, identification number, features, etc.
3. Indicate locations and sizes of fans, pumps, compressors, air handling equipment, dampers, etc.

4. Provide preliminary layout and elevation of equipment room and/or central system showing configuration, tie-ins, etc., as necessary to describe system.
5. Provide central heating or cooling plants, distribution piping, equipment.
6. For buildings where space pressurization is critical for occupant safety (such as a laboratory building), provide a room pressurization drawing that shows the relative room pressures in relation to each other in critical spaces.

2.6.2.8.16 Electrical Drawings

Power and lighting plans may be combined if submittal clearly conveys required information.

1. Lighting plans for each floor showing approximate fixture location, type, and lighting level required (in foot-candles).
2. Power distribution plans showing location of incoming service, generators, and panelboards.
3. Show interface points for communications, fire alarm, EMCS and other pertinent systems.
4. Floor proposed locations for receptacles, telephone outlets and switches.
5. It is the A/E's responsibility to contact the utility company during development of the project design in order to determine the available fault current at the project site.
6. Provide the following for fire alarm systems:
 - a. Indicate locations of the fire alarm system alarm-initiating and notification appliances
 - b. Indicate locations of the fire alarm control and trouble signaling equipment

2.7 WORKING DRAWINGS

2.7.1 General Requirements for Capital Projects

The A/E shall visit the site as necessary to ascertain pertinent local and site conditions. Based on the preliminary plans (Design Development Documents) including the review and the value engineering comments and resolution thereof, the A/E shall prepare the working drawings and specifications. The working drawings shall set forth in detail the requirements for the construction of the entire project and include the applicable bidding information. The A/E

shall assist in the preparation of the bidding forms, the Special Conditions of the Contract and the Contract Between Owner and Contractor, CO-9.

Specifications and drawings for any type of built-in equipment must be submitted with the working drawings for the building, whether or not such equipment is to be procured under another contract, in order that such work can be coordinated and bid on at the same time.

If any change from the information submitted at the preliminary design relating to the mix or amount of space is made, the University shall submit the revised information including justification, legislative approval, or other documentation related to the change.

The A/E shall submit 90% working drawings including draft technical specifications for review by the University.

The A/E shall include on the working drawings and in the specifications all necessary information to describe the components for the fire-resistive rated construction assemblies and fire protection systems needed to provide the necessary fire integrity of the structure for compliance with all applicable governing Codes.

2.7.2 Cost Estimate

The A/E shall submit a detailed Cost Estimate in conformance with the requirements of DCSM section 2.2, and advise the University of any adjustments to previous statements of estimated construction cost. The A/E shall submit a signed Building Cost Summary Sheet with the estimated cost of work covered by the working drawings and specifications and square footage of the proposed building data completed. If this data varies significantly from that shown on the Preliminary Cost Estimate, the A/E will attach an explanation to the working drawing Cost Estimate. For large projects, the University may choose to have an independent cost estimate made using copies of the working drawings and specifications. This may be beneficial in determining if the project is likely to be within budget and in determining sufficient clarity and detail of the documents for bidding.

2.7.3 Permits and Utilities

The A/E shall assist the University in filing the required documents for approval of authorities having jurisdiction over the project. If the Contractor will be required to interface with, coordinate with, or obtain inspection or approvals from any local authority or utility, the requirements and the name and address of such entity shall be shown in the documents.

2.7.4 Calculations

Calculations must be organized, indexed, numbered and submitted for each discipline involved.

Design calculations shall identify assumptions, considerations and factors involved in the design and support the design shown on the plans and specifications.

2.7.4.1 Structural Calculations

Calculations for every structural member are not required. Structural calculations for members representative of the various types of structural elements should be submitted. If submitted, computer printouts shall clearly indicate the individual member being analyzed or shall be accompanied by diagrams labeled with member numbers corresponding with the printout. The A/E shall be responsible for storing the complete set of calculations.

2.7.4.2 Plumbing Calculations

Include calculations for the following:

1. Plumbing fixture counts
2. Domestic cold water demand
3. Domestic water heater and hot water storage sizing
4. Primary and secondary roof drainage system sizing
5. Sanitary demand

2.7.4.3 Fuel Gas Calculations

Include calculations for the following:

1. Gas piping
2. Flue vent sizing

2.7.4.4 HVAC Calculations

Include calculations for the following:

1. HVAC building heat gain/loss
2. Ventilation (outside) air per space
3. Air distribution duct sizing and static pressure
4. Equipment selections including but not limited to: fans, coils, chillers, boilers, pumps, cooling towers
5. Hydronic and steam piping expansion and anchoring
6. Refrigerant system capacity and volume
7. Fuel oil supply and storage sizing

2.7.4.5 Energy Conservation Calculations

Include calculations for the following:

1. Compliance with the VT CAC
2. Building envelope thermal resistance and U-values

2.7.4.6 Electrical Calculations

Include calculations for the following:

1. COMCheck verification
2. Demand load for all switchboard, panelboards and feeders to multiple loads in a tabular form
3. Voltage drop calculations
4. Photometrics of emergency lighting along the entire path of egress, at the same scale as the floor plan provided in the working drawings. Note: If egress paths are not indicated on the plan, it will be assumed that the lighting levels for the entire room or area will need to meet the required illumination levels required by the VCC.

2.7.5 Submittal Requirements

Working drawings shall be complete, coordinated, and ready for approval to bid. The working drawings including the specifications shall bear a uniform date as described in this Manual. The drawings shall consist of Architectural and Engineering drawings in such detail as to show clearly the work to be performed. These drawings shall be planned to produce a set of plans with all disciplines coordinated to describe the work required. Architectural and engineering details shall be included on the drawings with cross references on both the plan and the detail sheets designating specifically the location to which the particular detail applies. Do not include details which do not apply to the particular project.

Submit the following:

1. Working Drawings
2. Project Manual (include front end documents, specifications, and appendices if applicable)
3. Updated A/E Project Cost Estimate
4. Calculations

2.7.6 Record Drawings and Specifications

The A/E shall prepare “Record Drawings” showing the “As-Built” conditions, locations and dimensions based on the Contractor’s As-Built set of drawings

and specifications, and other data furnished by the Contractor to the A/E. The Record Drawings shall reflect the actual equipment installed on the project instead of the Basis of Design equipment.

The Record Drawings shall include actual location and depth of piping and utilities as well as all other changes specifically known to the A/E. These Record Drawings shall also include the depths of foundations in the construction (pilings, caissons, or rammed AGG, etc.). Record documents shall be provided to the University in electronic PDF and AutoCAD® (DWG) formats, in addition to any other physical format required by the University.

2.7.7 Requirements for Working Drawings

Working drawings shall show or provide the following information:

2.7.7.1 General Requirements

Each drawing to be reproduced shall include:

1. Project Title,
2. Project location
3. The 11 digit state Project Code,
4. Drawing/Sheet Title,
5. Drawing/Sheet number (unique sheet number),
6. Name of the A/E,
7. Professional seal(s) of the responsible licensed professional(s) without signatures and dates,
8. The uniform date of the completed documents

2.7.7.2 Title Sheet(s)

1. Project Identification: University, Project Code, Appropriation Act Title.
2. Activity or function(s) to be performed in the facility.
3. Edition (year) of the VUSBC on which the design is based.
4. Applicable accessibility standards.
5. VCC Construction Type
6. (Use) Group(s) per VCC. For mixed-use occupancies, indicate which Groups are separated and non-separated.
7. Other major code(s) used as a basis for design
8. Asbestos Disclosure Statement and Lead Disclosure Statement
9. Dig Notice: Add "Contact Virginia 811 at 811, 1-800-552-7001, or <http://www.va811.com> no less than 72 hours prior to excavation and do not disturb the soil until dig ticket has been processed."

10. Points of Contact: Include owner representatives, construction managers, utilities, and communications contractors as appropriate.
11. Statement of compliance with the VT CAC
12. Maximum VCC occupancy for each level and total for the building
13. Location and vicinity maps noted to show project location
14. Tabulation of GSF per floor (new and renovated), total GSF (all floors– new and renovated), total building volume.
15. Tabulation of “Building Area” per VCC definition (per story)
16. Tabulation of units: Number of parking spaces, auditorium seats, bedrooms, etc.
17. Building Purpose/Occupancy.
18. Design occupant load for each level and total for the building
19. Index of drawings
20. The uniform date of the completed construction documents
21. Design Live Loads for all floors
22. Professional seal(s) of the architect(s) and engineer(s) responsible for the design.

2.7.7.3 Site Drawings

Site/improvement plan and composite utility plan minimum for new construction and additions; shall be based on an approved comprehensive Master Plan. Specific site drawing requirements shall be in accordance with the VTAS&S and coordinated with SID.

1. Provide scale and north arrow.
2. Provide new and existing contours affected by work.
3. Provide floor and contour elevations.
4. Provide applicable boundaries with survey computations.
5. Provide georeferenced attributes for site drawings.
6. Provide dimensioned relationship of new work to boundaries and existing structures.
7. Indicate location of test borings.
8. Indicate general parking and accessible parking.
9. Indicate accessible routes
10. Indicate pedestrian traffic routes.
11. Indicate demolitions: structures, walks, utilities, trees, etc.
12. Indicate proposed landscaping (planting materials). See DCSM section 2.3.2.
13. Indicate existing and new utilities: storm sewers, sanitary sewers, water supply, gas, steam distribution pipes and tunnels, electric and telephone

- poles and lines, data infrastructure, and hydrant locations with data on fire flow test.
14. Indicate site improvements such as fencing, lighting, etc.
 15. Provide typical paving section of each type and thickness required.
 16. Indicate special earthwork recommended and construction considerations noted in soils report.
 17. Construction site fencing and locations.
 18. Details of the following conditions will be required:
 - a. Over-excavation and replacement with suitable materials.
 - b. Subsurface profiles (boring logs) and limits showing the extent of rock, existing fill materials, water and existing unsuitable bearing materials.
 - c. Specific notes shall state that earthwork is included in the base bid. Earthwork beyond the extent indicated will be considered for an extra cost, only if necessary and approved by the A/E, and not a result of the Contractor's failure to maintain site/excavation stability, drainage or protection from frost penetration.

2.7.7.3.1 Earthwork

Earthwork drawings for structures and pavements include clearing and grubbing, excavation, fill/backfill, compaction, and grading.

Show the following information on the project drawings:

1. Location and record of soil boring, water level observations and test pits.
2. Soil classification(s) per ASTM D2487 and properties.
3. Hydrological data including 100-year floodplain (where available).
4. Surface elevations, existing and new.
5. Location of underground obstructions and existing utilities.
6. Sources of borrow material and soil classification(s) of borrow, if located on state property
7. Limits of areas to be cleared of trees, shrubs, and brush.
8. Disposal areas for brush and wasted soil, if available on state property.
9. Description/details of any special subgrade requirements or use of synthetic fiber filter fabric.
10. Details of special construction such as under railroad or highway right-of-way.
11. Areas to receive topsoil and to be seeded or sodded identified.

12. Erosion/sediment control measures and storm water management facilities
13. Typical cross sections of embankments or roadway construction indicating depths and extents of special compaction.
14. Details of subsurface drain construction (incl. foundation drains, drains behind retaining walls).
15. Have specifications been tailored for this project?
16. Has “suitable soils” listing been tailored to suit this project?
17. Have procedures for filling, backfilling and compaction been specified?
18. Have specifications identified the tests to be performed on the fill/backfill and the standards to be met to assure proper compaction?

2.7.7.3.2 Clearing and Grubbing

Show the following information on the project drawings:

1. Limits of clearing
2. Property lines
3. Trees and shrubs to remain in area to be cleared and detail of protection required
4. Trees to be removed in areas which are not to be cleared
5. Identify area to be totally cleared and grubbed.

2.7.7.3.3 General Excavation, Backfilling and Compaction

Show the following information on the project drawings:

1. Surface elevations (contours, spot elevations or both), existing and new;
2. Location of underground obstructions and existing utilities;
3. Location of borings and test pits and logs of soil borings and test pits. Include ground water observations and topsoil thickness encountered in boring, soil classifications.
4. Location of borrow and disposal area if located on state property;
5. Clearing stripping and grubbing limits, if different from clearing limits;
6. Areas to be seeded or sodded identified;
7. Hydrological data including 100-year floodplain, where available;
8. Shoring and sheeting (if required) and design requirements/criteria to be used by Contractor's shoring and sheeting designer
9. Pipe trench excavation details.

10. Erosion/sediment control measures and storm water management facilities

2.7.7.3.4 Excavation, Backfill and Compaction for Utilities

Show the following information on the project drawings:

1. Location and logs of soil borings, water level observations, and test pits.
2. Hydrological data including 100-year floodplain (where available).
3. Surface elevations, existing and new.
4. Location of underground obstructions and existing utilities.
5. Sources of borrow material if on state property or at a prearranged source.
6. Limits of areas to be cleared of trees, shrubs, and brush.
7. Disposal areas for brush and wasted soil if on state property.
8. Location and length of continuous concrete cradles, arches, or sleeves. Details/table of width and depth of trenches and pits for each type of pipe or appurtenance. Details of bedding for each type of pipe in varying earth and rock conditions; backfill details.
9. Typical detail of method of stabilizing weak foundation material.
10. Details of special construction such as under railroad and highways right-of-way requirements for jacking and boring.
11. Details of sewage absorption trenches, absorption pits, and subsurface drains.
12. Identify, detail, or note areas to receive topsoil and to be seeded or sodded and thickness of topsoil to be placed.
13. Details of pavement repair.

2.7.7.3.5 Erosion and Sediment Control/Stormwater Management

Show the following information on the project drawings:

1. Temporary control devices required during construction.
2. Permanent control devices to regulate rate of runoff water and to control future erosion.
3. Stabilization methods for soil stockpiles.
4. Temporary and permanent erosion control and stabilization methods for borrow/waste areas.

2.7.7.3.6 Pavement and Associated Work

Show the following information on the project drawings:

1. Typical section of each type or thickness of pavement showing dimensions and geometry, slopes, etc.
2. Dimensions defining the limits and shape of the paved areas
3. Details with dimensions of curbs, curb and gutter, raised islands, medians, curb cuts, ramps, and drainage structures
4. Layout of parking spaces, pavement markings, traffic control signage, and painted indicators including accessible parking spaces meeting requirements of the ADA Standards for Accessible Design, latest edition
5. Existing and new grading contours or spot elevations
6. New contours and spot elevations of paved areas showing drainage swales, slopes and directions of drainage flow
7. Drainage structures including manholes, drop inlets, piping, culverts, sizes of piping/culverts and lighting standard locations.

2.7.7.3.7 Fence, Chain Link

Show the following information on the project drawings:

1. Fence alignment
2. Posts: Minimum height to accommodate fabric and clearance, post size for line posts, corner posts, pull posts and gate posts.
3. Post setting dimensions: Not less than indicated in chain link manufacturer's installation standards. Assure that embedment length in concrete slabs and walls will be at least 12 inches. Show typical details for each condition to be encountered.
4. Chain link fabric: Show height and size or gauge on detail or section;
5. As required: Top rail, bottom rail, top and bottom reinforcing wires, and where a higher degree of security is required other than provided by fabric, include barbed wire on supporting arms. Note method of supporting arm attachment to post tops (bolts, screws, tamper-proof fasteners or welding).
6. Sleeve type expansion couplings: Specify/note as maximum of 21 feet on centers, if used.
7. Gates: location, size, and type. Include framing members size, weight, bracing, locking hasps, hinges, center pins, etc.
8. Where special fencing requirements exist, such as wolf-proofing, antiburrowing provisions, crossing drainage ditches, provisions for electrical installations, or special security installations, specifications

should be modified and appropriate details included on the drawings. Modifications and details should afford security equal to that of the fence.

9. Where special entrance security requirements exist such as electronic locks, motor operated gates, closed circuit video; add details and modify the specification accordingly.
10. Other information necessary to indicate layout and general configuration of the fence.

2.7.7.3.8 Turf

Show the following information on the project drawings:

1. Clearly indicate all areas to be turfed and if more than one type of turf is specified, delineate areas for each type.
2. All turf specifications shall be written to reflect the environmental conditions peculiar to the project area.

2.7.7.3.9 Landscaping, Trees and Shrubs

Show the following information on the project drawings:

1. Description, number and size of trees and plants;
2. Layout/location of various trees and plants including groupings;
3. Details of planting requirements including depth and diameter of excavations, mulching, protection, and supports;
4. Layouts and controls for irrigation systems if included in project;
5. Are tree and plants located away from existing and new underground utility lines, site improvements and surface drainage patterns?

2.7.7.4 Demolition Drawings

For total building demolition:

1. Provide plan of building with length and width dimensions,
2. Provide elevations (drawn or photographic) and cross section of building to be demolished,
3. Limits of demolition
4. Depth of demolition and detail for termination of foundations/walls
5. Provide details of termination of demolition, underpinning, etc.
6. Locations of any monitoring stations required for vibration, wellpoints, etc.
7. Provide Asbestos and Lead Disclosure Statements

For interior/selective demolition:

1. Provide floor plans showing existing partition and showing or describing existing material and construction to be removed
2. Provide information or estimates for bidding for work to be removed.
3. Provide Asbestos and Lead Disclosure Statements

2.7.7.5 Landscape Architecture Drawings

Include the following drawings. See DCSM section 2.3.2 for drawing requirements.

1. Existing conditions
2. Site demolition
3. Layout and dimensions
4. Accessibility plan
5. Scoring plan
6. Wayfinding/signage plan
7. Grading plan
8. Planting concepts
9. Planting schedule
10. Site details

2.7.7.6 Foundations

2.7.7.6.1 Round Timber Piles

Show the following information on the project drawings:

1. Plan layout (singles and clusters, show cluster layout)
2. Batter pile angle.
3. Design loads
4. Location of test pile, unless option to allow direction by the engineer is selected.
5. Tip elevation (estimated elevations/depths for bidding).
6. Cutoff elevation (top elevation)
7. Subsurface soil data logs shall be shown on the drawings. The entire soils report must also be included in an appendix to the specifications.
8. Staging area, if other than within the limits of work shown on the site plan.
9. Sections, details, dimensions and reinforcement of pile caps.

2.7.7.6.2 Concrete Filled Steel Casing Piles

Show the following information on the project drawings:

1. Plan layout (singles and clusters, show cluster layout)
2. Batter pile angle
3. Design load capacity
4. Location of test pile, unless option to allow direction by the engineer is selected
5. Tip/base elevation (estimated elevations/depths for bidding)
6. Cutoff elevation (top elevation)
7. Subsurface soil data logs shall be shown on the drawings. The entire soils report must also be included in an appendix to the specifications
8. Staging area, if other than within the limits of work shown on the site plan
9. Size of casing
10. Concrete strength and details of reinforcing
11. Sections, details, dimensions and reinforcement of pile caps

2.7.7.6.3 Pressure-Injected Footings or Piles

Show the following information on the project drawings:

1. Plan layout (singles and clusters, show cluster layout)
2. Batter pile angle
3. Design load capacity
4. Location of test pile, unless option to allow direction by the engineer is selected.
5. Bottom elevation (estimated elevations/depths for bidding)
6. Cutoff elevation (top elevation)
7. Subsurface soil data logs shall be shown on the drawings. The entire soils report must also be included in an appendix to the specifications.
8. Staging area, if other than within the limits of work shown on the site plan.
9. Size of shaft
10. Concrete strength and details of reinforcing
11. Sections, details, dimensions and reinforcement of pile caps

2.7.7.6.4 Steel Sheet Piles

Show the following information on the project drawings:

1. Plan layout
2. Batter pile angle

3. Tip elevation (estimated elevations/depths for bidding)
4. Cutoff elevation (top elevation)
5. Subsurface soil data logs shall be shown on the drawings. The entire soils report must also be included in an appendix to the specifications.
6. Staging area, if other than within the limits of work shown on the site plan.
7. Grade of steel
8. Pile shape and weight

2.7.7.6.5 Precast/Prestressed Concrete Piles

Show the following information on the project drawings:

1. Plan layout (singles and clusters, show cluster layout)
2. Batter pile angle.
3. Design pile load capacity
4. Location of test pile, unless option to allow direction by the engineer is selected.
5. Tip elevation (estimated elevations/depths for bidding)
6. Cutoff elevation (top elevation)
7. Subsurface soil data logs shall be shown on the drawings. The entire soils report must also be included in an appendix to the specifications.
8. Size and shape and unit stresses for prestressing strands or wire.
9. Detail of splices
10. Detail of reinforcing and tendons
11. Sections, details, dimensions and reinforcement of pile caps

2.7.7.6.6 Rolled Steel Section Piles

Show the following information on the project drawings:

1. Plan layout (singles and clusters, show cluster layout)
2. Batter pile angle.
3. Design pile load capacity
4. Location of test pile, unless option to allow direction by the engineer is selected.
5. Tip elevation (estimated elevations/depths for bidding).
6. Cutoff elevation (top elevation)
7. Subsurface soil data logs shall be shown on the drawings. The entire soils report must also be included in an appendix to the specifications.

8. Staging area, if other than within the limits of work shown on the site plan.
9. Sections, details, dimensions and reinforcement of pile caps

2.7.7.6.7 Drilled Foundation Caissons (Piers)

Show the following information on the project drawings:

1. Subsurface soil data and logs.
2. Top and estimated bottom elevation of each caisson.
3. Size (diameter in inches), bearing capacity, and total number of each size of caissons.
4. Dimensions of the bell, if required.
5. Dimensions of the casing.
6. Reinforcing steel details, if required.
7. Location of caissons to be penetration tested, if required.
8. Location of caisson to be proof tested, if required.
9. Locations, size, bell dimensions, and installation sequence of load testing caisson, if required.
10. Pilot hole size and depth into rock, if required

2.7.7.7 Concrete

2.7.7.7.1 Cast-in-Place Concrete

The documents shall provide sufficient details with data on the various configurations or conditions of the concrete and reinforcing steel to facilitate bidding and shop drawing preparation. Details shall include, but not be limited to, rebar size, location and spacing, location and lengths of splices, and required embedment lengths and cover. Typical details with tabular information are acceptable with special sections and details shown as needed. Clearly indicate that the design of formwork and shoring required for construction are the responsibility of the Contractor. The documents may require that the design of the formwork and shoring be performed by a licensed professional engineer and that the design responsibility shall rest with the Contractor and his engineer.

Show the following information on the project drawings:

1. Loading assumptions;
2. Material strengths used in design;
3. Yield strength of reinforcement required;

4. Details of reinforcement bars, showing number, sizes, bends, laps and stopping points of bars; location and details of stirrups; and mechanical connections to reinforcement bars;
5. Show wire size and weight or wire size and spacing of wire fabric reinforcement and locations where used;
6. Details of concrete sections, showing dimensions, reinforcement cover, and required camber;
7. Expansion, contraction and construction joint locations with dimensions and details;
8. Details and locations of critical construction joints, including waterstop locations and splices, keys and dowels when required;
9. Locations where structural lightweight concrete or lightweight insulation or fill concrete will be used;
10. Show locations and details for depressed structural slabs where required for static- disseminating and spark-resistant tile, terrazzo or other floor finishes in order to provide finished surfaces at the same elevations;
11. When exposed concrete surfaces are specified, the locations in the finished structure shall be indicated. If other than cast finish is required, the type and location shall be indicated.

2.7.7.7.2 Cast-in-Place Post-Tensioned Concrete

The documents may require that the post-tensioning system be engineered by the Contractor. Clearly indicate all design, loading and performance criteria as well as all pertinent design assumptions. Contractor is required to provide calculations and shop drawings for the post-tensioning system sealed by a licensed professional engineer. The A/E shall review these submittals for conformance with the design requirements.

2.7.7.7.3 Precast Concrete (Non-Prestressed)

The documents may require the Contractor to provide these components as an engineered system. Clearly indicate the layout and configuration of the units as well as the complete performance requirements. The Contractor shall be required to provide calculations and shop drawings of the units sealed by a licensed professional engineer. The A/E shall review these submittals for conformance with the design requirements.

Show the following information on the project drawings:

1. Live and dead (and lateral) loads for design. Note whether the topping is included in the specified dead load;
2. Details and locations for fitting, bearing, and connections;
3. Location of expansion and control joints;
4. Style and area of steel fabric reinforcement in areas where required. Kind and size of reinforcing bars and spacing;
5. Strength and type of concrete;
6. Detail of placement of sealant or fillers in joints;
7. Fire rating;
8. Lightweight concrete unit weight;
9. Special requirements for concrete cover over reinforcing;
10. Areas where toppings are required, indicate areas where the full thickness of the topping is not present.

2.7.7.7.4 Precast, Prestressed Concrete

The documents may require the Contractor to provide these components as an engineered system. Clearly indicate the layout and configuration of the units as well as the complete performance requirements. Contractor is required to provide calculations and shop drawings of the units sealed by a licensed professional engineer. The A/E shall review these submittals for conformance with the design requirements.

Show the following information on the project drawings:

1. Live and dead (and lateral) loads for design and whether topping is included in the dead load;
2. Details and locations for fitting, bearing, and connection of units;
3. Location of expansion and control joints;
4. Camber;
5. Style and area of steel fabric reinforcement in areas where required. Kind and size of reinforcing bars and spacing;
6. Strength and type of concrete;
7. Detail of placement of sealant or fillers in joints;
8. Fire rating;
9. Lightweight concrete unit weight;
10. Tendon types, physical properties, and allowable design stresses;
11. Special requirements for concrete cover over tendons and other reinforcing;
12. Areas where toppings are required, indicate areas where the full thickness of the topping is not present.

2.7.7.8 Utilities

2.7.7.8.1 Exterior Water Distribution System

Show the following information on the project drawings:

1. Plan and location of all new pipelines, including size and type of pipe.
2. Show or specify maximum working pressure of the system.
3. Location, size, and type of service of existing connecting, intersecting, and adjacent pipelines and other utilities.
4. Paved areas and railroads which pass over new pipelines.
5. Profile, where necessary to show existing parallel or crossing underground piping, conduits, clearances or unusual conditions.
6. Note class or thickness of pipe, including material identification if more than one class or thickness is used. Show limits for each where class or thickness will be different for different sections of pipeline.
7. Bedding conditions.
8. Details and locations of critical flanged joints, joints made with sleeve-type mechanical couplings, grooved and shouldered type joints, and insulating joints.
9. Locations of valves, hydrants (showing which are traffic type hydrants), indicator posts and details concerning valves, where necessary).
10. Show or specify size and shape of hydrant operating nut and cap nuts if nonstandard nuts are required; dimensions of threads (major diameter, minor diameter, pitch diameter, thread form, and number of threads per inch) on hydrant hose and pumper connections if nonstandard threads are required.
11. Connection of service line to water main, if different from that specified.
12. Location or size of thrust blocks, including type; or location of and details of metal harness, when necessary. The metal harness, when necessary, must be shown for polyvinyl chloride (PVC) plastic water main pipe.
13. Details for fire hydrant installation.

2.7.7.8.2 Site Steam or Hot Water Distribution System

The project drawings should show the following information:

1. Plan and location of all new pipelines, including size of pipe.
2. Show or specify maximum working pressure of the system.

3. Location, size, and type of service of existing connecting, intersecting, and adjacent pipelines and other utilities.
4. Paved areas and/or railroads which pass under or over new pipelines.
5. Profile, to show elevations, manholes, laterals, crossing utilities, and unusual conditions.
6. Note class or thickness of pipe, including material identification if more than one class or thickness is used. Show limits for each where class or thickness will be different for different sections of pipeline (unless clearly described in specs).
7. Locations, types and typical and/or special details of above grade and in tunnel pipe supports and pipe guides.
8. Locations of expansion loops or expansion joints.
9. Locations and details of anchors.
10. Locations and typical and special details of pipe tunnels and trenches.
11. Points of connection.
12. Location and details of concrete thrust blocks.
13. Location and details of manholes.
14. Location and size of main and branch line valves
15. Location and size of vents and drains.
16. Location and detail of drip legs, trap stations, trap schedule, and method of condensate recovery.
17. Diagrams of electronic circuitry for controls and instrumentation shown.

2.7.7.8.3 Storm Drainage System

Show the following information on the project drawings:

1. Plan and location of all new pipelines, including type of service and size of pipe.
2. Location, size, and type of service of existing connecting, intersecting, or adjacent pipelines and other utilities.
3. Paved areas and railroads which pass over new pipelines.
4. Profile, where necessary to show existing parallel or crossing underground piping, conduits, clearances or unusual conditions.
5. Invert elevations at beginning and end of pipelines and at manholes or similar structures.
6. Note class or strength of pipe and limits for each where class or strength will be different for different sections of pipeline. Indicate shape requirements if different shapes available.

7. Design details for all stormwater system structures including manholes, catch basins, curb inlets, and head walls.
8. Storm drainage lines and culverts required to be watertight.
9. Bedding details and location of cradle(s), when cradle is required.
10. Location, size, elevation and details, if necessary, for stormwater retention basin or structure.

2.7.7.8.4 Exterior Sanitary Sewer System

Show the following information on the project drawings:

1. Plan and location of new pipelines, including type of service and size of pipe.
2. Location, size, and type of service of existing connecting, intersecting, or adjacent pipelines and other utilities.
3. Paved areas and railroads which pass over new pipelines.
4. Profile, where necessary to show existing parallel or crossing underground piping, conduits, clearances or unusual conditions.
5. Invert elevations at beginning and end of pipelines and at manholes or similar structures.
6. Note class or strength of pipe and limits for each where class or strength will be different for different sections of pipeline.
7. Design details for pertinent manholes, septic tank(s), and sewage absorption trench including Health Department requirements.
8. Bedding conditions, where different from those specified in the appropriate specification and location of cradle(s), when cradle is required, if not covered.
9. Sections and details of pump stations.
10. Location and size of thrust blocks on pressure lines.
11. Location of flanged joints on pressure sewers if only used on part of line.
12. Location of mechanical joints on ductile iron piping (if used on only part of the system).
13. Location, size, and type of service of existing connecting, intersecting, and adjacent pipelines and other utilities.

2.7.7.8.5 Chilled, Condenser or Dual System Water Systems

Show the following information on the project drawings:

1. Single line plan and necessary sections indicating location, sizes and routing of associated piping. Piping larger than 4" diameter should be shown by double lines.

2. Locations of anchors, expansion loops and fittings.
3. Details of anchors and guides.
4. Flow diagrams for system(s).
5. Appropriate schedules and details for equipment or components.

2.7.7.8.6 Steam or Hot Water Distribution Systems (Interior)

The project drawings should show the following information:

1. Plan and location of all new pipelines, including size of pipe.
2. Maximum working pressure of the systems.
3. Location, size, and type of service of existing connecting, intersecting and adjacent pipelines and other utilities.
4. Locate and detail the pipe entry through building wall or slab. Include detail of interface between the tunnel or box trench and the building
5. Isometrics to show elevations, manholes, laterals, crossing utilities and unusual conditions.
6. Locations, types and typical and/or special details of pipe supports and guides.
7. Locations and isometric of expansion loops.
8. Locations and details of anchors. Indicate pitch of pipe and direction.
9. Points of connection.
10. Location and size of main and branch line valves
11. Location and size of vents and drains.
12. Location and detail of drip legs, trap stations, trap schedule and method of condensate recovery.

2.7.7.9 Architectural Drawings

1. Floor Plans (for each floor)
 - a. Plans of each floor at $\frac{1}{8}'' = 1'-0''$ scale, minimum
 - b. Overall dimensions
 - c. Space names and numbers
 - d. Relationship of new work to existing spaces
 - e. Distinguish new work from existing construction
 - f. Identification of openings, entrances, delivery areas (including door numbers)
 - g. Identification of accessible routes accessible building entrances, and Areas of Refuge
 - h. Include signage package that complies with VT interior signage standards manual.

- i. Calculations to support the indicated design occupant load on a use and function and floor by floor basis. Include the design occupant load for the function of each room and space in accord with the VUSBC
 - j. Plan scale and north arrow
 - k. Indicate demolition on the architectural plans or separate plans.
 - l. Fully dimension all spaces and components of the design
 - m. Add interior elevations for primary common spaces such as lobbies, atria, and rooms with casework, tile, accessories, and special build-ins or similar conditions that require extra attention.
 - n. Expansion joints
2. Reflected Ceiling Plans
- a. Ceiling tile/grid layout and ceiling height(s)
 - b. Lighting fixture locations
 - c. Sprinkler head locations
 - d. HVAC diffuser and grille locations
 - e. Clouds, coffers, drop soffits, changes in height or materials
 - f. Expansion joints
3. Roof Plan and Details
- a. Existing and proposed roof drain.
 - b. Means of secondary (emergency) roof drainage
 - c. Indicate direction of roof slope with arrows, high to low: $\frac{1}{4}$ " per 1'-0" minimum to drains (unless waived for reroofing)
 - d. Crickets in low slope roofs
 - e. Existing and new equipment.
 - f. Walk pads to and around equipment
 - g. Roof penetrations and structures
 - h. Expansion joints
 - i. Access to roof and guards
 - j. Identify materials of existing roofs and new roofs
 - k. Thermal insulation R value
 - l. Fully dimension
 - m. Typical roofing section identifying materials
 - n. Edge and transition details
 - o. Flashing details at all penetrations
4. Exterior Elevations (scale: $\frac{1}{8}$ " = 1'-0" minimum)
- a. Openings: windows (including operable notation), doors, louvers, vents
 - b. Percentage of glass vs. gross wall area (per elevation and/or exposure)
 - c. Floor elevations

- d. Identification of all major finishes
 - e. Stairs, ramps, and railings
 - f. Rooftop equipment and structures
 - g. Expansion and control joints
 - h. Grade at the face of the building wall
 - i. Subsurface construction (dotted in)
 - j. Distinguish new work from existing construction
5. Building Cross Sections (scale: 1/16" = 1'-0" minimum)
- a. One longitudinal and one transverse section, minimum
 - b. Indication of floor elevations
 - c. Indication of ceilings in relation to floors
 - d. Method and extent of insulation of exterior envelope
6. Wall Sections and Enlarged Plans/Details
(scale: 3/4" = 1'-0" minimum at wall sections, 1/4" = 1'-0" minimum at enlarged plans)
- a. One section for each type of wall construction, fully noted and dimensioned
 - b. Identification of materials and components
 - c. Identification of insulation type including "R" value
 - d. Identification of air barrier and moisture barrier with details at transitions
 - e. Enlarged details as required including at window heads, window sills, door heads, transitions between materials, cornices, and parapet walls.
 - f. Enlarged partial floor plans for each stair and elevator at each floor and one section with dimensions and details for each stair and elevator configuration, minimum.
 - g. Enlarged partial floor plans for each toilet room configuration, dimensioned and noted to identify accessible fixtures
7. Finish Schedule
- a. Finishes for all spaces. Note those existing finishes to remain.
 - b. Ceiling heights of interior spaces.
 - c. Clarify finishes, textures, colors, etc., required to be provided by the Contractor
8. Door Schedule
- a. Indicate size and material for each door and door frame
 - b. Indicate glazing size and material for each door and frame
 - c. Indicate fire resistance rating for each door and frame
 - d. Cross reference a specified hardware set for each door assembly

- e. Provide door type elevations, frame details, head details, threshold details, and access control details

2.7.7.9.1 Ceramic Tile, Quarry Tile and Paver Tile

Show the following information on the project drawings:

1. Rooms, areas, or spaces that are to be tiled such as floors, walls, wainscots (give heights), shower rooms and compartments; and, sink, vanity, or work table tops and splash backs, should be shown in the finish schedule.
2. Bases, thresholds, and treatment at windows, doors and trimmed openings, including sills and vertical returns back to window or door frames, should be properly detailed.
3. Spaces which require cleavage membrane or membrane waterproofing.
4. Where a mortar bed is required, and where it is desired that surface of tiled floor be flush with adjacent floor, indicate depressed structural slab or sub-floor.
5. A schedule showing tile types, sizes, patterns, trim, and built-in tile accessories required for each room or space. Identify type of trim shape by the designations of ANSI A137.1.
6. Do not indicate sizes if specified in this section.
7. Slope of floors to drain is 2% or less.
8. Details and locations of expansion and control joints in tile walls or floors.
9. Treatment at tile recesses for radiators, convectors, drinking fountains, lighting fixtures, and other recessed items.
10. Locations where concrete walls or partitions, or masonry walls are to be furred to receive ceramic wall tile.

2.7.7.9.2 Acoustical Treatment

Show the following ceiling information on the project drawings:

1. Location of acoustical tile ceiling (ATC) systems. If more than one type of system is used, key each system to locations on the reflected ceiling plan or the Finish Schedule using symbols ATC-1, ATC-2, etc.
2. Arrangement of panels, light fixtures, diffusers, other penetrations and exposed suspension grids when used are shown on the Reflected Ceiling Plan. Have these items been coordinated with Mechanical and Electrical?

3. Maximum spacing of suspension members for concealed grid suspension systems.
4. Location and material of fire stops above suspended ceilings.
5. Location of systems required to have ceiling sound transmission class (STC), fire endurance ratings, or both.
6. Details of special or patterned panels if necessary to describe adequately.
7. Where acoustical ceilings are provided in conjunction with thermal insulation beneath vented attic spaces, under certain types of roof decks, careful attention should be given to furnishing adequate details on the contract drawings. Such features as support of insulation over flush-mounted light fixtures, conduit, acoustical units, and suspension system components and around heating, air conditioning, and other utilities shall be covered by the details. Appropriate specification shall be included in the Project Manual to cover the installation of insulation over the suspension system, light fixtures, and other ceiling penetrations. See DCSM section 5.15.5.1 for more details on acoustical tile ceilings.

2.7.7.9.3 Resilient Tile Flooring

Show the following information on the project drawings:

1. Type, location and layout pattern of floor tile.
2. Type and location of base, stair treads, edge strips, and joints between resilient and other types of flooring.
3. Manufacturer's name and number. Note on drawings or in specs: Colors listed are for color identification purposes only. Listing is not intended to limit selection of equivalent textures and colors from other manufacturers.

2.7.7.9.4 Painting

Drawings shall include project documentation such as details, sections, elevations and/or schedules which indicate the type and extent of work. Specific quantities of work shall not be cited in the specification.

Work shall be coordinated between the drawings and specifications and include the following:

1. Reputtying and reglazing
2. Resealing of existing exterior joints
3. Removal of existing coatings

4. Has potential for lead paint and/or asbestos been investigated and addressed on renovation projects?
5. Has finish schedule been coordinated with this specifications section?
6. Are types of paint compatible with materials being painted?
7. Are number of coats of paint shown in schedule or specified?
8. Do specifications establish the level of workmanship required for painting?

2.7.7.9.5 Toilet and Bath Accessories

Show the following information on the toilet room plans and elevations:

1. Mounting heights required above finished floor to comply with the ADA Standards for Accessible Design, latest edition, where required to be accessible
2. Locations of all fixtures, partitions and accessories including plan and elevation dimensions.
3. Number of accessories required.
4. Clearances as required to comply with the ADA Standards for Accessible Design, latest edition

2.7.7.10 Furnishing/Equipment Plans

1. Provide outline of equipment to scale.
2. Provide outline of built-in furnishings to scale.
3. Provide elevations, sections and details as necessary to describe built-in equipment, casework and furnishings included in the Work of the Contractor.
4. Identify accessible built-in furnishings and equipment.
5. Provide working clearance measurements around equipment.

2.7.7.10.1 Food Service Equipment

Show the following information on the project drawings:

1. Locations of accessible handwashing sinks
2. Equipment location, including all elements located in counters and dishwashing counters and at sinks.
3. Size, material and details for custom-fabricated equipment.
4. Floor, wall, and ceiling penetrations. Include mounting height and size of pass through window at soiled dish counter.
5. Locations for raised bases, retainer curbs, or depressions.
6. Locations for recessed, grated floor drains required for equipment.

7. Locations for exhaust fan curbs, supply fan curbs, exhaust duct, supply duct, and ductwork material.
8. Location for fire suppression system tanks and actuating stations.
9. Locations and type of hoods, plumbing enclosure housing and control panel of automatic washdown system.
10. Location and detail drawing of insulated floors, including under-floor perforated drains and vent pipes.
11. Location of disposer control centers.
12. Locations of disconnect switches.
13. Location and detail drawings of electrical chases and raceways and plumbing chases. Assure that underfloor electrical chases are provided to and among cash registers.
14. Location of remote compressors and refrigeration systems.
15. Location of all utility connections to building water, sanitary, gas, electrical, sprinkler, fire alarm, oil, compressed air, steam, and other utility systems. Include convenience outlets at point of use of plug-in equipment.
16. Detail drawings should be provided to show water metering devices located to provide one device to serve two kettles where practical.
17. Details of the remote pressurized syrup containers and associated supply lines to drink dispenser(s).

2.7.7.10.2 Laboratory Equipment and Fume Hoods

Show the following information on the project drawings:

1. Location of equipment, by unit number.
2. Location of utility connection.
3. Relation to adjacent trades.
4. Remotely located blower and ductwork, to create negative pressure at hood. Require appropriate weatherproof caution labels attached to outlet end of exhaust duct systems where warning of dangerous chemical fumes will be necessary for the protection of workmen in the vicinity.
5. Optimum face velocity.
6. Fans and ductwork needed to create negative pressure. Laboratory fume hoods are ventilated enclosures designed to provide a safe working area for laboratory activities involving hazardous materials, generated fumes, aerosols, gases, and particulate matter. To operate satisfactorily, air is removed from this enclosure at an optimum face velocity. Require velocities measurable at the maximum face area of

the hood, with maximum allowances for hood, filter, and appurtenance static pressure losses within the specified limits.

7. Locations of accessible equipment and hoods

2.7.7.11 Structural Drawings

1. Unless indicated otherwise below, the structural drawings shall provide complete details of all structural components so that no additional structural design will be required for the preparation of shop drawings except for standard connection details and fabrication calculations.
2. Indicate design live loads, snow loads, wind loads, and seismic criteria used for design of structural systems per VCC Chapter 16.
3. Indicate design bearing/support capacity (soil bearing, pile capacity, caisson capacity) for foundation system.
4. Engineered design and details of engineered systems such as cast-in-place post-tensioned concrete, precast concrete components, steel joists and joist girders, pre-engineered metal structures, and shop/prefabricated wood components may be required to be provided by the Contractor. In this case, the structural drawings shall include complete loading information as well as all other performance or size constraints for the components.
5. Structural drawings shall include plans at the same scale as the architectural plans. Details and sections shall be at a scale of not less than $\frac{3}{4}" = 1'-0"$.
6. The plans, details and specifications shall completely define the structural system and special conditions for the project.
7. Provide foundation plans indicating type and sizes.
8. Provide foundation details of improved bearing strata and other special requirements.
9. Provide floor framing plans of each level indicating type of system and member sizes/depths and column spacing.
10. Provide roof framing plans.
11. Provide typical section(s) of floor and roof systems identifying materials, thicknesses, and depths.
12. Provide details of connections to existing buildings, if applicable.

2.7.7.12 Special Requirements

2.7.7.12.1 Pre-engineered Metal Buildings

The documents may require that pre-engineered metal structures be provided by the Contractor as engineered systems. All design and

performance criteria must be indicated in the documents. The supporting structure for the engineered system shall be detailed on the drawings with the assumed reactions from the engineered system indicated. The Contractor shall be required to provide calculations and shop drawings for these systems prepared by a Virginia licensed professional engineer. The A/E shall review these submittals for conformance with the design requirements.

Show the following information on the project drawings:

1. Floor and eave height dimensions required
2. Clear spans, clear heights necessary
3. Roof slope required (or minimum and maximum slope)
4. Type of roof and wall coverings
5. Approximate locations for downspouts, roof ventilators, louvers, and skylights
6. Location and required R factor of insulation
7. Depth of roof and wall coverings, if necessary
8. Location of liner panels
9. Minimum design roof dead, live, and snow loads.
10. Basic wind speed in miles per hour.
11. Collateral loads for special equipment or crane loads, special live loading
12. Importance factor for wind and seismic computations.
13. Foundation plan with dimensions and details and the allowable design bearing capacity of soil on which this design is based. Require Contractor to include in his price any modifications necessary for his building.
14. Where applicable, state the allowable horizontal drift between the pre-engineered metal building and adjacent or adjoining construction.

2.7.7.12.2 Unit Masonry (Brick and/or CMU)

Show the following information on the project drawings:

1. Locations and dimensions of each kind of masonry work;
2. Masonry compressive strength (fm), type, and fire rating, if required;
3. Mortar types and where used;
4. Vertical reinforcing bar size and spacing where required;
5. Horizontal reinforcing and spacing;
6. Control joint locations;

7. Expansion joint locations;
8. Bond pattern if other than running bond;
9. Through-wall flashing and weep details.
10. Control joint and expansion joint details;
11. Special brick shapes if required;
12. Bond beam locations, sizes, and reinforcing;
13. Lintel locations;
14. Lintel schedule with sizes, shapes, components, reinforcing, etc.;
15. Details of anchorage of masonry to supporting structure;
16. Details of bearings on masonry and of anchorages to masonry.

2.7.7.12.3 Structural Steel

The documents shall provide complete details of the configuration of the structural steel and of any non-standard connections. The detailing of standard connections shown in AISC's Manuals of Steel Construction, Allowable Stress Design and Load and Resistance Factor Design may be left to the Contractor. If this is done, the documents must clearly indicate all design loads and other criteria required for the development of connection details. The A/E shall review the shop drawings and verify design adequacy of fabricator detailed connections. The Contractor shall not be required to provide a licensed professional engineer for the design of these connections.

Show the following information on the project drawings:

1. Yield strength of steel used in design;
2. The extent and location of structural steel;
3. Designations of steel members;
4. Centerline dimensional locations of framing members;
5. Top of steel elevations above or below a reference elevation;
6. Connection details of typical connections;
7. Details of special and moment resisting connections;
8. Beam or girder camber, if required;
9. Shoring information and typical details, if shoring required during construction;
10. Locations where galvanized steel will be used;
11. Size and shape of crane rails;
12. Types of connections (welded and bolted), including adjustable runway support connections if overhead, top running cranes are provided;

13. Locations where high strength bolts and slip critical connections are required and the loads and stresses required if design is provided by Contractor;
14. The location of welds requiring nondestructive testing, along with type of testing required;
15. Lateral bracing members/framing;
16. For composite beams show shear stud number, size and spacing required.

2.7.7.12.4 Steel Joists and Joist Girders

Standard open web steel joists and joist girders shall be indicated by size, type and spacing on the drawings. For non-standard loading conditions, the documents may require that the components be provided by the Contractor as an engineered system. In this case, clearly indicate all loading and design criteria. The Contractor shall be required to provide calculations and shop drawings for these components prepared by a licensed professional engineer. The A/E shall review these submittals for conformance with the design requirements.

Show the following information on the project drawings:

1. Joist series, size and spacing, point loads (if any), and slope;
2. Joist girder depth, kip load on each panel point, span, and slope;
3. Design loads, including uplift and lateral forces in addition to gravity (dead and live) loads;
4. Method of anchoring joists to supports;
5. Stiffeners at point/concentrated loads;
6. Framing between joists at openings through supported roof or floor;
7. Framing at equipment being supported by joists/joist girders;
8. Spacing and type of bridging and bracing;
9. Accessory details as applicable;
10. Bearing details on masonry.

2.7.7.12.5 Steel Decks

Indicate which roof areas on the structure are considered by the structural engineer as functioning as diaphragms for the lateral force resisting system. Composite decks and diaphragm acting decks, including connections, should be designed by the structural engineer according to the Steel Deck Institute and details shown on the drawings. Drawings must show wind uplift loads for roof joist design in addition to the items listed below.

In addition to the above, show the following information on the project drawings:

1. Structural properties (height, sheet thickness, section moduli, moment of inertia).
2. Openings in floor and roof deck and typical detail of framing at opening
3. Location, spacing, and size of hanger clips or loops for critical locations.
4. Closure plates, where required.
5. Location of cellular decking and whether it is to be used as electrical raceway.
6. Weld or fastener spacing and size of same
7. Whether construction is based on shored construction.
8. End and side lap details

2.7.7.12.6 Cold-Formed Metal Framing

Show the following information on the project drawings:

1. The extent and location of all cold formed metal framing
2. Indicate gage, size, section modulus, and other structural properties required.
3. Connections and other installation details.
4. Indicate concentrated loads that may overstress a flange or connection (e.g., pipe supports).
5. Slip connection requirements at underside of roof members

2.7.7.12.7 Metal Fabrications

Show the following information on the project drawings:

1. Location and configuration of all metalwork.
2. All sizes and dimensions.
3. Special fastenings, attachments or anchoring.
4. Location and size of expansion shields larger than a $\frac{3}{8}$ -inch diameter.
5. Location and identification of products to be galvanized.
6. Location and special details of expansion joint covers.
7. Connection details (other than manufacturer's standard) of grating.
8. Locate and detail removable sections of handrails.
9. Location and support detail of ladders.
10. Location and details of all structural steel door frames.
11. Sections, dimensions, sizes and details of all metal stairs.

2.7.7.12.8 Rough Carpentry

Show the following information on the project drawings:

1. Location and magnitude of concentrated loads
2. Grade and stress rating of structural lumber
3. Sizes and spacing of all wood framing members including trusses
4. Location, size, type, and thickness of all materials
5. Size and spacing of special fasteners
6. Details of connections
7. Size and spacing of anchor bolts
8. Details of all connections and anchorage where special conditions exist such as high wind, hurricane, and earthquake areas
9. Locations where treated lumber is required including type of treatment (preservative or fire retardant treatment)
10. Details of depressed floors to receive ceramic tile

2.7.7.12.9 Prefabricated Wood Components

The documents may require that prefabricated wood components such as glue laminated structural members and trusses, metal plate fabricated wood trusses, and similar shop fabricated wood structural systems be provided by the Contractor as engineered systems. All design and performance criteria must be indicated in the documents. The Contractor shall be required to provide calculations and shop drawings for these systems prepared by a licensed professional engineer. The A/E shall review these submittals for conformance with the design requirements.

2.7.7.12.10 Finish Carpentry

Show the following information on the project drawings:

1. Location, size, type, and thickness of materials;
2. Size and spacing of special fasteners or attachments;
3. Special details, sections and requirements of millwork;
4. Type and/or pattern of prefinished material;
5. Profile and size of trim;
6. Color and/or pattern of prefinished material
7. Profile and size of trim
8. Location and species of any wood that is to be stain, natural, or transparent finish

2.7.7.12.11 Exterior Insulation and Finish System

Show the following information on the project drawings:

1. Locations of exterior insulation and finish systems (EIFS).
2. Thermal resistance value (R-value) for each location if various R-values are used.
3. If several levels of Impact Resistance are specified, indicate locations where each level is required.
4. Joint layout on elevations.
5. Details at edges and at joints and of special profile

2.7.7.12.12 Elevators

Show the following information on the project drawings:

1. Fire-rated hoistway, with vent at top where required by code.
2. Waterproofed pit, with ladder, indirect drain or sump, light and ground fault circuit interrupter (GFCI) receptacle.
3. Machine room, with ventilation to maintain temperature, light and outlet, and fire extinguisher. Do not run pipes, ducts, conduits, etc., through or over the machine room or locate other equipment in the machine room. For new machine rooms in existing buildings, show how pipes, ducts, conduits, etc., are relocated.
4. Hoist beam at top of shaft, removable if necessary for overhead clearance.
5. Smoke detectors in each lobby and machine room to initiate firefighter's return.
6. Heat detectors in shaft and machine room to activate elevator return.
7. Power feeders to machine room with disconnects for elevator machine and cab lighting, phone connection in machine room.

2.7.7.13 Roofing

2.7.7.13.1 Roof Insulation

Show the following information on the project drawings:

1. The extent and locations of the work to be accomplished.
2. Dimensions when space limitations or construction features govern thickness of insulation materials.
3. Details at cants, edge strips, and nailers.
4. Location and spacing of wood nailers.
5. Location, type and spacing of special anchorages to substrate
6. Extent of tapered insulation and slope

2.7.7.13.2 Preformed Metal Roofing and/or Siding

Show the following information on the project drawings:

1. Roof slope.
2. Location, sizes, and details of flashing, closure strips, and accessories.
3. Depth, thickness/gage, and configuration of roof and wall panels.
4. Spacing of girts and purlins.
5. Design loads for sizing girts and purlins.
6. Method of attachment to supports

2.7.7.13.3 Preformed Steel Standing-Seam Roofing

Show the following information on the project drawings:

1. Roof slope
2. Supporting structural framework.
3. Intermediate support and attachment details, when applicable.
4. Attachment clip spacing.
5. Flashing support and fastening spacing.
6. Roof venting. (Detail to show method of preventing infiltration of wind-driven rain.)
7. Sealant and closure locations.
8. Locations for dissimilar metal protection.
9. Details of all accessories such as ladders, walkways, antenna mounts, guy wire fastening, ventilation equipment and lightning rods.
10. Details of flashing at all roof penetrations. On roof plan add note to offset penetrations such that center of penetrations coincide with mid-point of panel seams.
11. Detail how expansion of roofing will be accounted for.
12. Locations where panels will be anchored/attached/restrained.

2.7.7.13.4 Aggregate-Surfaced Bituminous Built-Up Roofing

Show the following design, details and information on the roof drawings:

1. Roof penetrating components such as roof drains and vents shall not be located within 18 inches of each other, of the toe of cant strip, or at juncture of roof with wall or other vertical surfaces.
2. Roof drains with approved clamping rings and removable large dome strainers are used.
3. Equipment mounted on curbs or structural supports are of sufficient height to accommodate roof flashings and installation of roofing under equipment.

4. Structural supports are circular (pipe columns) to greatest extent practicable to permit use of circular collars with flashing flanges and umbrella flashing with clamping rings. Avoid use of pitch pockets, if possible.
5. Curbs shall not restrict drainage of water from roof.
6. Expansion joints in roofing shall be provided at each expansion joint in the structure.
7. Details of expansion joints in roofing placed on curbs 8 inches high, minimum, above the membrane. Expansion joints shall not restrict drainage of water from roof.
8. Indicate preservative treated wood cants at base of curbs for structural support.
9. Area dividers in the roofing shall be provided:
 - a. where the roof deck changes direction and where substrate materials change;
 - b. uniformly spaced not over 200 feet apart on section of roof that exceeds 200 feet in length or width;
 - c. at each intersection where L- or T-shaped roof deck changes direction; and
 - d. where there is a difference in elevation between adjoining decks.
10. Area dividers shall be located at high points, where practicable, shall not prevent drainage of water from the roof, and shall be placed on curbs above the water line.
11. Flashing details provided at points where items will mount on or penetrate roofing membrane and at points requiring a typical flashing. Use isometric drawings as required to clearly indicate intersections of different types of flashings.
12. Slope of substrate/roofing with directional arrows and live load limits.
13. When backnailing of felts is required on a non-nailable deck, provide treated wood nailers, as a minimum, as follows:
 - a. Spaced no more than 21 feet apart (clear dimension), same thickness as insulation, and at right angles to roof slope on decks with roof insulation;
 - b. Spaced no more than 21 feet apart, embedded flush with deck top surface, and parallel to roof slope on decks without roof insulation; and
 - c. At right angle to roof slope of barrel roofs and spaced and installed as for decks with or without insulation, as applicable.
14. Extent, location, and configuration of roof planks and walkways shown.

15. Are treated wood nailers compatible with roofing material specified?

2.7.7.13.5 Elastomeric Sheet Roofing System (EPDM)

Show the following information on the project drawings:

1. Flashing and counterflashing at perimeter of roofing, pipe, conduit and other roof penetrations, and curbs. (Do not use sealant filled pitch pans for flashing roofing penetrations unless there is no alternative.)
2. Expansion joints in the roofing at each expansion joint in the structure, placed on curbs above the waterline, and not restricting drainage of water from the roof.
3. Roof drains not placed within 18 inches of other penetrations, expansion joints, or walls.
4. Roof-mounted equipment on curbs or structural supports of sufficient height to accommodate roof flashings and installation of roofing under the equipment. Curbs shall not restrict drainage of water from the roof.
5. Roof walkways for traffic areas and access to mechanical equipment. Provide openings in walkways to permit drainage of water from the roof.
6. Slope of substrate/roofing with directional arrows.
7. Live load limits of roof construction to caution against overload during stockpiling roofing materials.

2.7.7.13.6 Flashing and Sheet Metal

Show the following information on the project drawings:

1. Base, counter, open valley, and eave flashing
2. Roof drain flashing
3. Expansion joints – The contract drawings should contain details of building expansion joints at walls, ceiling, floors, roof, and parapets. Include exterior and interior details. Provide isometric detailing for expansion joints intersections.
4. Sheet metal roofing – show extent, slope, method of attachment and provisions for thermal movement of roofing
5. Downspout locations, gauge, size, and method of attachment
6. Gutter size, gauge, locations, and method of attachment

2.7.7.14 Openings

Include a complete door schedule. The door schedule should assign a separate number for each opening and should indicate:

1. the door type and style,
2. material,
3. design (whether flush panel, full flush, paneled, glazed, or louvered),
4. size and thickness,
5. glazed or unglazed,
6. fire rating class for fire doors,
7. hardware set number (may be here or in specifications),
8. threshold material, if any,
9. material for frames, mullions, and transom bars.

It is recommended that standard door-type nomenclature, SDI 106, be used to indicate designs (e.g., “F, L, G, GL, etc.” in lieu of “A, B, C, etc.”).

2.7.7.14.1 Steel Doors and Frames

Show the following information on the project drawings:

1. Sizes of door openings, direction of swings, and travels of doors.
2. The side of wall or partition where door is to be located.
3. Details of nonstructural mullions, mullion covers, and removable mullions.
4. Type and thickness of glazing required; whether or not insulating glass units are required.
5. Method, type, number and spacing of anchors required for anchoring door frames to adjoining construction.
6. The type of doors and frames required for various openings, and optional types of materials and construction, if any.
7. Indicate locations which require safety glass (on plan or in schedule)
8. Indicate the free area for louvers in doors.
9. Indicate whether fire doors are required on one or both sides of the fire wall.

2.7.7.14.2 Aluminum Doors and Frames

Show the following information on the project drawings:

1. Size of door openings, thickness, swing and travel of doors and design; whether flush, paneled, glazed, or louvered; width of stiles and rails
2. Elevations of each door and frame type, at ¼-inch scale

3. Details of head, jamb, sill, mullions, and transom sections; key sections to door frame elevations; type and spacing of anchors
4. Type and thickness of glazing required and method of glazing
5. Details of weatherstripping for exterior doors
6. Amount of free area for louvers
7. A separate number for each door opening on door schedule

2.7.7.14.3 Wood Doors

Show the following information on the project drawings:

1. Locations and travel of doors
2. Sizes, types, and thicknesses,
3. Glazing and louver requirements
4. Designs
5. Fire rating requirements
6. Color or finish
7. Door swing
8. Sound transmission class

2.7.7.14.4 Detention Hollow Metal Frames, Doors and Door Frames

Show the following information on the project drawings:

1. Sizes of door or view window, speaking port, louver, view port and food pass, if any, openings, thicknesses of doors, swings, and travels of doors.
2. Indicate detention hollow metal doors as Sec. Holl. Mtl. or SHM and show that the term means Detention Hollow Metal Doors and Frames, in a schedule of abbreviations.
3. The size of wall or partition where door is to be located.
4. Type and thickness of glazing required.
5. Method, type, and spacing required for anchoring frames to adjoining construction.
6. Include a complete door schedule. The door schedule should assign a separate number for each opening and should indicate the door type and style, material, design, size, thickness, hardware set number, threshold material, if any.

2.7.7.14.5 Metal Windows

Show the following information on the project drawings:

1. Type of material
2. Sizes and types of windows;

3. Metal and wood subframes, casings, or stools, if any;
4. Hardware required.
5. Sizes, location, and swing of ventilators; direction of slide for sliding ventilators;
6. Location and details of fixed sash.
7. Typical window sections and details.
8. Show glass thickness. Show special glazing such as safety glass, if any.
9. Method of anchoring windows to adjoining or adjacent construction; note size and types of clips, anchors, screws, or other fasteners in details.
10. Details of nonstructural mullions and mullion covers; details of anchoring and reinforcing nonstructural mullions at windows to receive window cleaner anchors.
11. Number of window cleaner anchors required and locations.
12. Locations of windows requiring special operators, if any. Show method of operation and concealment of operators, cables and rods, as appropriate. Show wiring diagram for motor driven operators, if any.
13. Locations of windows designated as forced entry resistant, if any.
14. Locations of fire-rated windows, if required.

2.7.7.14.6 Finish Hardware

Show the following information on the project drawings:

1. Location, class, and hourly rating of fire doors;
2. Location and installation details for blocking behind door stops (wall bumpers) mounted on wallboard partitions; and
3. Hardware set numbers (e.g., HW-2) in the door schedule or list doors by number in each hardware set in the specifications.
4. Are the following items included in the schedule: thresholds, automatic door bottoms, weatherstripping, acoustic seals, kick plates, panic hardware?

2.7.7.14.7 Glazing

Show the following information on the project drawings:

1. Locations of each type of glass, using the same terminology used in the specification.
2. Thickness of glass, unless glass of each type is the same thickness.
3. Frame and rabbet details, indicating method of glazing.

2.7.7.14.8 Glazed Curtain Wall System

Show the following information on the project drawings:

1. Large scale details showing the sizes and configuration of principal wall system framing members, panels, and other components as well as details of flashings, copings, weep, and drainage system.
2. Methods of securing system framing to structures and details of fastenings, anchors, and auxiliary shapes.
3. Details of expansion joints and each type of typical joint.
4. Type and thickness of glass and details showing methods of glazing for all conditions.
5. Details for installing each type of panel specified.
6. Details of any required field applied thermal insulations, sound insulations, baffles, fillers, fire stops, or other seals at joints between curtain wall and edges of floor slabs.
7. A schedule showing the various types and sizes of system units and of all window units.

2.7.7.15 Fire Protection and Fire Safety Systems

2.7.7.15.1 Fire Protection Information Plan and Calculations

Provide the following as a minimum to demonstrate compliance with the code:

1. Applicable edition of the VUSBC and other applicable codes, including accessibility standards.
2. (Use) Group(s) per the VUSBC. For mixed-use occupancies, indicate which Groups are separated and non-separated.
3. Construction Type per the VUSBC.
4. Indicate type and extent of fire protection sprinkler system and fire detection/fire alarm systems.
5. Tabulation of square footage per floor and total building area including new square footage, existing square footage to be renovated, other existing square footage, and total building volume (cubic feet).
6. Tabulation of units: Number of auditorium seats, bedrooms, etc.
7. Calculations to support the indicated design occupant load on a use and function, and floor by floor basis. Include the design occupant load for the functions of the rooms and spaces in accord with the VUSBC.

8. Indicate paths of means of egress, paths of exit access, travel distances and common paths of travel. Indicate specific locations where access controls or security locking systems will be provided within means of egress paths.
9. For projects that will have partial, phased occupancy, indicate locations and construction of temporary barriers, fire resistance ratings of temporary barriers, locations of temporary exit signage, locations of temporary means of egress emergency lighting and the temporary exit access patterns at each floor for each substantially completed phase. Include fire watch requirements as needed.
10. Indicate rating of all fire resistance-rated assemblies, smoke barriers, and smoke partitions.
11. Completely show the continuity of vertical fire resistance rated assemblies, with reference symbols. Distinguish new walls from existing walls and new construction from existing construction.
12. Identify the extent of horizontal fire-rated floor/ceiling and roof/ceiling assemblies, with reference symbols.
13. Provide drawings that clearly define the locations and extent of the application of applied fire resistant materials.
14. Define the UL design assemblies specific to the respective locations and application of applied fire resistant materials.
15. Define the validation tests required for special inspections of applied fire resistant materials in the project. See DCSM section 2.7.7.15.8.
16. Indicate locations of all portable fire extinguisher cabinets.
17. Indicate whether the building is designated as an “essential facility” for purposes of compliance with seismic and snow provisions in the VUSBC.
18. Indicate the seismic design category.
19. Calculations in support of the indicated construction type, based on Group, allowable height and allowable area, and permitted or required height and area modifications.
20. Calculations to support the indicated design occupant load on a use and function and floor by floor basis.
21. Calculations to demonstrate and support the indicated capacity of the egress components throughout the building.
22. Provide a matrix that defines the “fire-resistance rating requirements” for building elements including exterior walls, fire walls, fire barriers, shaft enclosures, fire partitions, smoke barriers and horizontal assemblies. Matrix shall indicate the listed design

assemblies proposed to achieve the required fire resistance ratings. Include copies of each listed assembly.

23. Define the UL through penetration firestop assemblies for all utilities penetrating fire rated construction.

2.7.7.15.2 Fire Suppression Systems – Sprinklers/Standpipes

Changes to the design during the construction phase of the project shall be submitted to the UBO for review and approval. It is the responsibility of the A/E to provide a project specific design. Performance criteria do not meet the intent of this section.

1. Drawings

Provide the following as a minimum to demonstrate code compliance:

- a. Identify the occupancy hazard classification and show the location of sprinklers for each of the spaces on each floor within the buildings. The location of sprinklers are to be based on the VCC, NFPA 13 and the user's programmatic requirements with the understanding that the quantity, coverage, location and type of sprinkler are not to be altered by the Contractor, without prior written approval by the A/E and the UBO.
- b. Show the location of fire department valves and risers within the building. Indicate that the fire department valves are attached to either a standpipe riser, combined standpipe and sprinkler riser, or wet pipe sprinkler system risers. The locations of fire department valves are to be based on the VCC, NFPA 13, NFPA 14 and the user's programmatic requirements.
- c. Show proposed sprinkler piping and standpipe layout including the sprinkler mains (including cross mains) within the building and layout of branch lines for the most hydraulically demanding zone(s) on each floor of each sprinkler system. Indicate the size of pipes that are shown.
- d. Provide a table summarizing the characteristics of each of the sprinkler systems. Define the type of sprinkler system(s), areas of coverage, hazard, minimum rate of water coverage (density) per area, water required for each area of coverage, hose stream allowances for each area, total water requirements for each area of coverage, hydraulically calculated pressure requirements at a common reference point at design flow for each area of coverage, and water supply (flow and pressure) available at the common reference point.

- e. Provide a small scale drawing showing locations of water hydrants, test and flow hydrants (for waterflow tests), and routing of underground pipe. Indicate the waterflow Test results, the date and time taken and who conducted the test. Indicate the water supply (flow and pressure) at a reference point common with the sprinkler/standpipe system design.
 - f. Show and identify all existing sprinkler systems and standpipe systems.
 - g. Show and indicate all new connections to existing systems.
 - h. Provide sprinkler riser diagram with appropriate fittings, accessories, sizes, alarms, valves, etc., noted.
 - i. Show all system drains.
 - j. Show all inspector's test station locations and associated discharge/ drainage piping.
 - k. Show the location of the fire department connection(s) with all interconnecting piping to the sprinkler and standpipe systems.
 - l. Show the location and details of the fire pump, driver, fire pump controller, piping, components and piping specialties.
 - m. Show the location of the fire pump test header and all interconnecting piping.
 - n. Show sprinkler head type, K-factor and temperature ratings.
2. Specifications
- Provide the following as a minimum to demonstrate code compliance:
- a. Provide complete specifications to reflect the systems that are defined on the drawings.
 - b. Provide wording in the specifications that indicate that the type of systems, the location of major components, the quantity, type, coverage, location of sprinklers, and modifications to the distribution system are not to be altered by the Contractor, without prior written approval by the A/E and the UBO. Changes to the design depicted within the construction documents shall be submitted to the UBO for review and approval.
 - c. Provide a description of the acceptance testing requirements. Indicate which of the acceptance tests are to be witnessed by the regional State Fire Marshal's Office (SFMO).
3. Calculations
- Provide the following as a minimum to demonstrate code compliance:
- a. Provide final hydraulic calculations for each sprinkler system and standpipe system.

- b. The calculations shall demonstrate the performance of the system with an automatic water supply for the most hydraulically demanding zone on each floor of the building for each of the fire sprinkler systems compliant with NFPA 13 and NFPA 14.
 - c. The calculations shall also demonstrate the performance of the sprinkler and standpipe systems as connected to the manual water supply (fire department pumper truck – validate pumper truck performance with local fire department) by the fire department connection and interconnecting piping compliant with VCC, NFPA 13, and NFPA 14.
4. Shop Drawings Review
- Shop drawings (working plans, product data and calculations) are to be reviewed by the A/E of record for compliance to the project contract documents and the code. At the conclusion of the shop drawing review, the A/E of record shall:
- a. Verify the UL listings and classifications for the materials, components and equipment provided for this project result in a code compliant fire suppression system.
 - b. Provide a “sealed” statement, attached to the reviewed shop drawings indicating that the fire suppression shop drawings (working plans, product data and calculations) satisfy the requirements of the project contract documents and the code (cite the applicable NFPA Sections).
 - c. Provide the regional SFMO a copy(s) of the approved complete fire suppression shop drawings.
 - d. Refer to DCSM section 3.10.1.3 for additional requirements.
5. Validation of the Fire Suppression Systems
- Fire suppression systems are to be acceptance tested in accord with the requirements of the code. The regional SFMO shall observe the installed fire suppression system and witness the fire suppression system performance tests. The A/E and Contractor shall certify that the fire suppression system is complete.
6. Show the following information on the project drawings (See NFPA 13):
- a. Location and detail of each sprinkler system entrance to include:
 - i. supply riser,
 - ii. alarm valve,
 - iii. water motor alarm,
 - iv. fire department inlet connection,

- v. pressure or flow switch,
- vi. fused disconnect switch,
- vii. and associated electrical connections.
- b. Location where each sprinkler system begins including connection to water distribution system piping.
- c. Location of sprinkler system control valves, post indicator valves, wall indicator valves and inspector test stations.
- d. Area of sprinkler system coverage when system is protecting partial areas.
- e. Details of sprinkler piping anchors where required.
- f. On renovation projects, indicate existing sprinkler piping layout and sprinkler heads on project drawings only if existing sprinkler system is being modified and such layout is necessary for clarity or coordination with new work. Show new sprinkler system work.
- g. Show predominate hazard classification; identify any areas with a different classification
- h. Show information on water supply to include:
 - i. Water flow available in GPM,
 - ii. Static water pressure in psi,
 - iii. Residual water pressure in psi,
 - iv. Hydrant locations.

2.7.7.15.3 Fire Suppression Systems – Alternate Automatic Systems

Changes to the design during the construction phase of the project shall be submitted to the UBO for review and approval. It is the responsibility of the A/E to provide a project specific design. Performance criteria do not meet the intent of this section.

Alternate automatic systems include wet-chemical systems (NFPA 17A), dry-chemical systems (NFPA 17), foam systems (NFPA 11 and NFPA 16), carbon dioxide systems (NFPA 12A) and clean agent systems (NFPA 2001). Halon systems shall not be used in the design of new fire extinguishing systems in state owned buildings.

Commercial cooking suppression systems shall either be: a pre-engineered automatic dry and wet chemical extinguishing systems tested in accordance with UL 300, and labeled and listed for the intended applications, or developed in accordance with one of the above-referenced NFPA standards.

1. Drawings

Provide the following as a minimum to demonstrate code compliance:

- a. Show and identify rooms/spaces/components to be protected by the proposed fire suppression system.
- b. Show the enclosure partitions (full and partial height) of the protected area.
- c. Identify the locations of the major fire suppression system components.
- d. Show the routing of the fire suppression system lines between the stored agent and the dispersion nozzles within each of the protected spaces. Indicate sizes of pipes that are shown.
- e. Provide a table defining the type of fire suppression system(s), areas of coverage, hazard, minimum required concentration of fire suppression agent, volume of agent required for each area of coverage, total volume of agent for the areas protected by this system.
- f. Show and identify all existing fire suppression systems.
- g. Show the location of all dispersion nozzles for all spaces/areas protected.
- h. Show the locations and components of the automatic detection system and agent releasing system. Define the specific locations for actuation devices.
- i. Show the location of and define the interface requirements to connect to the building's fire alarm system.
- j. Show the location of components for means of manually releasing of agent.
- k. Location of controlled devices such as dampers and shutters
- l. Provide fire suppression system riser diagram with appropriate fittings, fire suppression agent storage tanks, accessories, sizes, alarms, valves, etc.
- m. Show and indicate all new connections to existing systems.
- n. Show the location of instructional signage.

2. Specifications

Provide the following as a minimum to demonstrate code compliance:

- a. Provide complete specifications to reflect the systems that are defined on the drawings.
- b. Provide wording in the Specifications that indicate that the type of system, concentration requirements, quantity of agent required, location and type of dispersion nozzles, location of major

components and modifications to the distribution system are not to be altered by the Contractor, without prior written approval by the A/E and the UBO. Changes to the design during the construction phase of the project shall be submitted to the UBO for review and approval.

- c. Provide complete step-by-step description of the system sequence of operations including functioning of abort and maintenance switches, delay timers, and emergency power shutdown.
 - d. Provide a description of the acceptance testing requirements. Indicate which of the acceptance tests are to be witnessed by the regional SFMO.
3. Calculations
Provide the following as a minimum to demonstrate code compliance:
- a. Complete calculations to determine enclosure volume and quantity of agent required.
 - b. Calculations to define the size of backup batteries
 - c. The method used to determine number and location of audible and visual indicating devices.
 - d. The method used to determine number and location of detectors.
4. Shop Drawings Review
Shop Drawings (working plans, product data and calculations) are to be reviewed by the A/E of record for compliance to the project contract documents and the code. At the conclusion of the shop drawing review, the A/E of record shall:
- a. Verify the UL listings and classifications for the materials, components, and equipment provided for this project result in a code compliant fire suppression system.
 - b. Provide a “sealed” statement, attached to the reviewed shop drawings indicating that the fire suppression shop drawings (working plans, product data and calculations) satisfy the requirements of the project contract documents and the code (cite the applicable NFPA Sections).
 - c. Provide the regional SFMO a copy(s) of the approved complete fire suppression shop drawings.
 - d. See DCSM section 3.10.1.3 for additional requirements.
5. Validation of the Fire Suppression Systems
Fire suppression systems are to be acceptance tested in accord with the requirements of the code. The regional SFMO shall observe the

installed fire suppression system and witness the fire suppression system performance tests. The A/E and Contractor shall certify that the fire suppression system is complete.

2.7.7.15.4 Fire Pumps

Changes to the design during the construction phase of the project shall be submitted to the UBO for review and approval. It is the responsibility of the A/E to provide a project specific design. Performance criteria do not meet the intent of this section.

1. Application of Fire Pumps in Fire Suppression Systems

A fire sprinkler/standpipe suppression System is to provide a reasonable degree of protection for life and property from fire based on sound engineering principles, test data, and field experience. One key component of the system is a reliable water supply of acceptable volume and pressure. The connection of the fire suppression system to a public water supply that is of acceptable volume and pressure is considered to be the most “reliable water supply.” Where the building characteristics are such that the water supply requirements of the designed fire suppression system cannot be provided by the available water supply then the incorporation of an automatically controlled fire pump into the fire suppression system, compliant with NFPA 20 *Standard for the Installation of Stationary Pumps for Fire Protection*, shall result in an “acceptable water supply.” Sound engineering principles are to be incorporated into the design of the fire suppression system to result in the most reliable and acceptable water supply for the project.

2. Electrical Requirements

Fire pump electrical components and systems shall comply with the National Electric Code (NFPA 70) section(s) on fire pumps. The power for fire pumps shall be from a service which is both electrically and mechanically separate from the remainder of a building’s power supply.

3. Emergency Electrical Systems

Fire pumps are considered to be an emergency system and shall comply with the additional electrical requirements of the National Electric Code (NFPA 70) section on emergency power, where any of the following condition(s) occurs:

- a. The building is more than 75 feet in height.

- b. The building has a total assembly design occupant load that exceeds 1,000 people.
 - c. The building is designated as an Emergency Shelter (VCC Section 1604.5).
 - d. Electric motor driven fire pumps are used and the height of the structure is beyond the capacity of the fire department apparatus.
4. Drawings
- a. Provide the following as a minimum to demonstrate code compliance:
 - b. Show the location of the fire pump, pressure maintenance pump, pump controllers, piping, components and piping specialties.
 - c. Provide details of the fire pump, pressure maintenance pumps, pump controllers, suction piping, discharge piping, components and piping specialties.
 - d. Provide a table summarizing the water supply characteristics for the most demanding area of each of the sprinkler systems supplied by the fire pump. Define the type of sprinkler system(s), water flow and pressure requirements for each area of coverage, hose stream allowances for each area, resulting total water flow and pressure requirements for each area of coverage, water supply (flow and pressure) available, fire pump, resulting available water supply, resulting safety factor in psig for each sprinkler system.
 - e. Provide a small scale drawing showing locations of water hydrants, test and flow hydrants (for waterflow tests), and routing of underground pipe. Indicate the waterflow test results, the date and time taken and who conducted the test. Indicate the water supply (flow and pressure) at a reference point common with the sprinkler/standpipe system design.
 - f. Show and identify all existing sprinkler systems and standpipe systems in the vicinity of the fire pump(s).
 - g. Show and indicate all new connections to existing systems.
 - h. Show the location of the fire department connection(s) with all interconnecting piping back to the fire pump.
 - i. Show the location of the fire pump test header and all interconnecting piping.
 - j. Show the location of the electrical components of the fire pump, driver, fire pump controller and ancillary electrical components.

- k. Show the location, size and routing of the conduits and conductors serving the fire pump, driver, fire pump controller, and ancillary electrical components.
 - l. Provide details of the electrical components serving the fire pump, driver, fire pump controller, piping, components and piping specialties.
 - m. Where multiple fire pumps or multiple sources of power are required, provide a diagram on the drawings that defines all of the applicable components and defines the sequence of operation.
5. Specifications
- Provide the following as a minimum to demonstrate code compliance:
- a. Provide complete specifications to reflect the systems that are defined on the drawings.
 - b. Provide wording in the specifications that indicate that the modifications to the fire pump and ancillary components are not to be altered by the Contractor, without prior written approval by the A/E and the UBO. Changes to the design during the construction phase of the project shall be submitted to the UBO for review and approval.
 - c. Provide a description of the acceptance testing requirements. Indicate which of the acceptance tests are to be witnessed by the regional SFMO.
6. Calculations
- Provide the following as a minimum to demonstrate code compliance:
- a. Provide hydraulic calculations that demonstrate that the most hydraulically demanding zone(s) of the fire sprinkler system(s) is satisfied by the automatic water supply (water supply plus fire pump) compliant with the requirements of NFPA 13, NFPA 14, and NFPA 20.
 - b. Where the height of the structure is beyond the capacity of the fire department apparatus, provide hydraulic calculations that demonstrate the performance of the standpipe system(s) as connected to the automatic water supply (water supply plus fire pump) compliant with the VCC, NFPA 13, and NFPA 14.
7. Existing Fire Pumps
- Where an existing fire pump is to be used in the project, its performance and condition is to be established and validated. This is to be accomplished by submitting a copy of the recent report of the fire pump inspection, testing, and maintenance, compliant with the

Virginia Statewide Fire Prevention Code: Fire Pumps – Testing and Maintenance. This section requires that fire pumps be inspected, tested, and maintained in accordance with NFPA 25. The current edition of NFPA 25 defines the parameters for the report. The performance and condition of the fire pump is to be validated on an annual basis.

8. Shop Drawings Review

Shop drawings (product data, sketches and certified shop test pump curves) are to be reviewed by the A/E of record for compliance to the project contract documents and the code. At the conclusion of the shop drawing review, the A/E of record shall:

- a. Verify the UL listings and classifications for the materials, components, and equipment provided for this project result in a code compliant fire pump system.
- b. Provide a “sealed” statement, attached to the reviewed shop drawings indicating that the fire pump shop drawings (product data, sketches and certified shop test pump curves) satisfy the requirements of the project contract documents, the VCC and NFPA 20.
- c. Provide the regional SFMO a copy(s) of the approved fire pump shop drawings.
- d. See DCSM section 3.10.1.3 for additional information.

9. Validation of the Fire Pump

The fire pump(s) is to be acceptance tested in accord with the requirements of the code. The regional SFMO shall observe the installed fire pump and ancillary components and shall witness the fire pump performance tests. The A/E and Contractor shall certify that the fire pump installation is complete.

10. Show the following information on the project drawings:

- a. Configuration, slope to drain, and sizes for each piping system;
- b. Location and type of each pump, including associated equipment and appurtenances;
- c. Capacity of each item of equipment;
- d. Locations and details for special supports for piping; and
- e. For pipe larger than 12 inches, details of anchoring piping including pipe clamps and tie rods.

2.7.7.15.5 Fire Detection and Fire Alarm Systems

The A/E shall provide complete project specific drawings and specifications that define a code compliant fire alarm system. User's programmatic requirements which may supplement or provide additional levels of protection above the minimum requirements of the code shall be included in the design. Changes to the design during the construction phase of the project shall be submitted to the UBO for review and approval. The A/E shall assure that code compliant fire alarm Systems(s) are provided through the review of the fire alarm shop drawings and the observation of the progress and quality of the work. The A/E shall confirm that the fire alarm system(s) is complete and code compliant. It is the responsibility of the A/E to provide a project specific design. Performance criteria do not meet the intent of this section.

1. Provide the following as a minimum to demonstrate code compliance:
 - a. Locate and identify all fire alarm system alarm-initiating and notification appliances.
 - b. Locate and identify where protective covers are utilized with fire alarm system alarm initiating and notification appliances.
 - c. Locate and identify all fire alarm control and trouble signaling equipment.
 - d. Locate and identify all existing alarm system alarm-initiating and notification appliances.
 - e. Locate and identify all existing fire alarm control and trouble signaling equipment.
 - f. Locate and identify the interface requirements for all fire alarm system alarm initiating devices provided by other trades such as HVAC duct smoke detectors, kitchen hood fire suppression systems, fire sprinkler flow and tamper switches.
 - g. Locate and identify the interface requirements for all devices whose operation is initiated by the fire alarm system such as door hold open devices, fire shutters, elevator recall, electronic door hardware and smoke control systems.
 - h. Identify the primary and secondary power supplies and connections.
 - i. Identify the candela output levels for all visual alarm notification appliances. Candela ratings such as "15/75" are not compliant.
 - j. Provide a matrix that defines the interface of the fire safety control functions. Define the action that will initiate an alarm or

trouble condition. Define the alarm-initiating device activated, the action of the control and trouble signaling equipment, and the resulting alarm notification appliance actions and resulting operation of interfaced equipment.

- k. Provide fire alarm system riser diagram showing all system components. Define the “zones” to be protected.
Diagrammatically define the location of the constantly attended location from which the fire alarm system will be supervised. Define the interface between the fire alarm system and the constantly attended location.
 - l. Provide wording in the Specifications that indicate that the location and type of fire alarm system alarm-initiating appliances and the type of fire alarm system alarm notification appliances and control and trouble signaling equipment, the location of major components are not to be altered by the Contractor, without prior written approval by the A/E and the UBO. Changes to the design during the construction phase of the project shall be submitted to the UBO for review and approval.
 - m. Provide a description of the acceptance testing requirements. Indicate which of the acceptance tests are to be witnessed by the regional SFMO.
 - n. Demonstrate that the quantity and location of the audible alarms as indicated on the drawings attain the required sound pressure levels in each of the respective spaces.
 - o. Demonstrate that the required capacity of the secondary power supply is attained.
 - p. Demonstrate that the indicated candela performance is attained for alarm notification devices where protective covers are utilized.
2. Shop Drawings Review
- Shop drawings (working plans, product data and calculations) are to be reviewed by the A/E of record for compliance to the project contract documents and the code. At the conclusion of the shop drawing review, the A/E of record shall:
- a. Verify the UL listings and classifications for the materials, components, and equipment provided for this project result in a code compliant fire alarm system.
 - b. Provide a “sealed” statement, attached to the reviewed shop drawings indicating that the fire alarm shop drawings (working plans, product data and calculations) satisfy the requirements of

the project contract documents and the code (cite the applicable NFPA).

- c. Provide the regional SFMO a copy(s) of the approved complete fire alarm shop drawings.
 - d. See DCSM section 3.10.1.3 for additional requirements.
3. Validation of the Fire Alarm Systems:
Fire alarm systems are to be acceptance tested in accord with the requirements of the code. The regional SFMO shall observe the installed fire alarm system and witness the fire alarm system performance tests. The A/E and Contractor shall certify that the fire alarm system is complete.
4. Show the following information on the project drawings:
- a. On electrical power floor plans, show location of control panel, battery and charger, transmitter, annunciator, fusible safety switch, remote trouble device, alarm devices and each actuation device including fire extinguishing system switches.
 - b. On electrical site plan, show location of master fire alarm box, annunciator, circuit run to the connection to the campus fire alarm circuit, circuit run into the building and connection to control panel, and circuit run for master box marker light. Circuit runs should show conduit size and numbers and size of conductors.
 - c. Show single line fire alarm riser diagram. Connection of equipment should be indicated by circuit runs in lieu of conduit runs. Do not indicate number and size of conductors for interconnection of fire alarm components.
 - d. Show mounting height for panels on elevation or detail drawings, if critical.
 - e. Location of visual annunciators (strobe lights) adjacent to exits or EXIT signs to meet requirements of the ADA Standards for Accessible Design, latest edition, and current applicable edition of NFPA 72.
 - f. Intercom system for Areas of Refuge.

2.7.7.15.6 Smoke Control Systems

Changes to the design during the construction phase of the project shall be submitted to the UBO for review and approval. The A/E shall assure that a code compliant smoke control system is provided through the review of shop drawings and the observation of the progress and quality

of the work. The A/E shall confirm that the smoke control system is complete and code compliant.

The VCC defines 3 methods of smoke control: 1) Pressurization Method, 2) Airflow Design Method, and 3) Exhaust Method. Large enclosed volumes, such as atriums, shall be permitted to utilize the Exhaust Methods. Smoke control systems using the Exhaust Method shall be designed in accordance with one of the five design approaches defined in NFPA 92B. The UBO's approval is required for the use of any of these methods within a project.

When the preliminary "Rational Analysis" is accepted by the UBO, complete and submit the final Rational Analysis documents with the Working Drawing design documents to the UBO for review and approval.

1. Rational Analysis:

Provide conceptual floor plans which identify the locations of the major components, pertinent calculations, sequence of operation and any other information that may assist in the evaluation of the methods are to be included in the documents submitted to the UBO. It is the responsibility of the A/E to provide a project specific design. Performance criteria do not meet the intent of this section.

2. Provide the following as a minimum to demonstrate code compliance:

- a. Locate and identify all of the walls, floors and ceilings that define the perimeter of the space(s) to be protected by the smoke control system.
- b. Locate and identify the HVAC system components respective to the smoke control system.
- c. Locate and identify all smoke dampers respective to the smoke control system.
- d. Locate and identify all motorized dampers respective to the smoke control system
- e. Locate and identify the interface requirements with the fire alarm system.
- f. Locate and identify the interface requirements for all devices whose operation is required by the smoke control system such as door hold open devices, smoke dampers, fire shutters, motorized ventilation dampers, fans, air handlers and smoke detectors.
- g. Identify the primary and secondary power supplies and connections.

- h. Provide wording in the specifications that indicate that the components of and their locations which make up the smoke control system are not to be altered by the Contractor, without prior written approval by the A/E and the UBO. Changes to the design depicted within the construction documents shall be considered substitutions in accord with the General Conditions and are to be documented by change order.
 - i. Provide a description of the acceptance testing requirements. Indicate which of the acceptance tests are to be witnessed by the regional SFMO.
 - j. Provide calculations as defined by the VCC and NFPA 92B that establish the performance requirements for the method of smoke control for this project.
 3. Validation of the Smoke Control System(s)
The smoke control system(s) are to be acceptance tested in accord with the requirements of the code. The regional SFMO shall observe the installed components of the smoke control system(s) and witness the smoke control system performance tests. The A/E and Contractor shall certify that the smoke control system is complete prior to acceptance testing by the UBO.

2.7.7.15.7 Access Control Systems

Shop drawings shall be submitted to the UBO for work elements including: electric strikes, electric latches, electric locks, magnetic locks and other electronic controls (card keys, access buttons, proximity sensors, etc.) even if used as an overlay on mechanical door hardware.

Provide the following as a minimum to demonstrate code compliance:

1. Building floor plans defining the locations and components of the access control hardware proposed.
2. Door hardware details and elevations defining the locations of all associated access control hardware.
3. A copy of the door hardware (mechanical hardware) shop drawings for the doors where the access controls are to be provided;
4. A sequence of operations demonstrating compliance with the requirements of the VUSBC.
5. Documentation demonstrating that each of the access control components are listed for the intended use and that per the manufacturer's documentation the specific components are compatible with each other;

6. A description of how the elements interface with the building's fire alarm system.

Other security measures including cameras, contact switches or other security items which do not affect means of egress are not required to be included.

2.7.7.15.8 Applied Fire Resistant Materials

The A/E shall provide complete project specific drawings and specifications that result in code compliant fire resistive construction through the use of applied fire resistant materials. Applied fire resistant materials include spray-applied fire resistant materials, fire resistant mastics and intumescent coatings. The A/E shall determine which members are required to be fireproofed and indicate the minimum thickness of the applied fire resistant materials to be applied. Changes to the design during the construction phase of the project shall be submitted to the UBO for review and approval. The A/E shall assure that code compliant fire resistive construction is provided through the review of the applied fire resistant material shop drawings and the observation of the progress and quality of the work. The A/E shall confirm that the fire resistive construction is complete and code compliant.

1. Provide the following as a minimum to demonstrate code compliance:
 - a. Provide drawings (small scale structural framing plans) including typical and special details that clearly define the locations and extent of applied fire resistant materials. Drawings should be structural steel plans without irrelevant walls, doors and other features that would obscure a clear representation of the extent of fireproofing.
 - b. Define the UL design assemblies specific to the respective locations and application of the applied fire resistant materials.
 - c. Provide complete Specifications to reflect the applied fire resistant materials assemblies that are defined on the drawings.
 - d. The specifications shall clearly state that no asbestos-containing material will be permitted. Contractor shall be required to certify that the material being used contains no asbestos.
 - e. Where structural steel members having different thicknesses (or none) of applied fire resistant materials intersect or connect, provide sprayed-on fireproofing equal to the greater thickness on

all members for a distance of 2 feet minimum from the junction of the members.

- f. Metal attachments such as miscellaneous angles, light gage framing, and hangers shall be covered in the areas of the attachment with the same thickness of applied fire resistant materials as the structural member.
 - g. All applied fire resistant materials shall be tested after installation according to ASTM E605, ASTM E736, ANSI/UL 263 and ANSI/UL 1709, latest editions. Include the specific validation testing requirements as defined below. These tests shall be made by an independent testing laboratory. The University shall arrange and pay for laboratory services for field and laboratory tests and reports. The Contractor shall schedule the tests while the material is accessible. If additional tests are required as a result of non-compliance with the specifications; the additional tests and reports shall be paid for by the Contractor.
 - h. The independent testing laboratory reports shall clearly show the location of the tests and test results. Copies of the reports shall be sent through the A/E to the VT PM. The VT PM will submit the test results to the SFMO and the UBO.
2. Removal and Replacement of Sprayed-on Material
- Agencies and/or their A/E shall contact the UBO early in the design phase to verify the original purpose of the fireproofing material to be removed or replaced and what, if anything, must be done to restore the fire resistance characteristics. Submit plans and specifications to the UBO which will include any bidding documents, addenda or change orders which may relate to the fire resistance characteristics of the existing structure. Include the date(s) of construction, original and present uses, height in floors and feet, whether sprinkled and any other information that may assist the UBO in his determination.
3. Shop Drawings Review
- Shop drawings (working plans, product data and calculations) are to be reviewed by the A/E of record for compliance to the project contract documents and the code. At the conclusion of the shop drawing review, the A/E of record shall:
- a. Verify the UL design assemblies and for the materials, and components provided for this project result in code compliant fire resistive construction.

- b. Provide a “sealed” statement, attached to the reviewed shop drawings indicating that the sprayed-on fireproofing shop drawings (working plans, product data and calculations) satisfy the requirements of the project contract documents and the code.
 - c. Provide the regional SFMO a copy(s) of the approved complete shop drawings.
 - d. See DCSM section 3.10.1.3 for additional requirements.
4. Validation of Sprayed-on Fireproofing Assemblies
- Applied fire resistant material assemblies are to be acceptance tested in accord with the requirements of the code and the requirements defined herein. The regional SFMO shall observe the installed fireproofing assemblies. The independent testing laboratory reports shall clearly show the location of the tests and test results. The A/E and Contractor shall certify that the sprayed-on fireproofing assemblies are complete. Copies of the reports shall be sent through the A/E to the VT PM. The VT PM will submit the reports to the SFMO and the UBO.
5. Validation Testing Requirements
- All applied fireproofing shall be tested after installation according to ASTM E605, ASTM E736, ANSI/UL 263 and ANSI/UL 1709, latest editions. The minimum location and number of tests of the applied fireproofing shall conform to the requirements below:
- a. For thickness on floor sections: One out of every four bays or similar units shall be inspected, but in no case shall a bay or unit exceed 2,500 sq. ft. Each bay or unit selected shall be divided into quarters. In each quarter, a 12-inch square shall be selected for taking thickness measurements. The thickness shall be determined by taking the average of at least ten individual symmetrical thickness measurements within the 12 inch square. Where more than one thickness is required by design, a similar procedure shall be followed for each of the required thicknesses.
 - b. For thickness on beams and columns: Beam and column thickness measurements shall be taken within each bay or similar unit in which floor insulation thickness measurements are made. Four sets of random measurements shall be taken for each bay or unit.
 - c. For density: Samples for density determination shall be taken for each 10,000 sq. ft. of pre-selected floor area, but in no case shall there be less than two per floor.

- d. For bond strength: Samples for cohesion/adhesion shall be taken on thoroughly dried material adjoining test sections used for thickness and density determinations. There shall be one test for beams and one test for decks for each 10,000 sq. ft. of pre-selected floor area, but in no case shall there be less than two tests per floor.
6. Show the following information on the project drawings:
- a. Location of all sprayed fire protection.
 - b. Thickness of sprayed on fire protection and rating required
 - c. Drawings should also show fire protection other than sprayed-on for the following items:
 - i. Concrete fire protection of steel bearing members in elevator hoistways.
 - ii. Plaster fire protection of structural steel and underside of steel decks in machine rooms.
 - iii. Equivalent masonry, concrete or plaster fire protection on outside surfaces of exterior structural peripheral members.
 - d. Bearing for members in certain areas may not require fire protection. Locations and members should be specifically identified on the drawings.

2.7.7.16 Plumbing Drawings

1. Indicate items to be demolished as part of renovation projects.
2. Provide plans for each floor noting locations and types of fixtures, water supply and distribution, sanitary drainage and special piping.
3. Provide plumbing fixture schedules showing designations, connection sizes, and mounting heights of accessible fixtures. Flush valve handles shall be located on the wide side of the accessible stall.
4. Provide plans indicating roof drains and areas served by each in square feet, piping and sizes.
5. Provide riser diagrams indicating fixtures, water supply and distribution, sanitary drainage and special piping.
6. Provide details of connections at water heaters, air compressors and roof drain installation.
7. Provide equipment schedules for water heaters, air compressors, air dryers and drains.
8. Configuration and sizes of piping systems
9. Locations of hot water and cold water shut-off gate valves for each toilet room

10. Dimensioned location and type or schedule number of each plumbing fixture with clearances as required to comply with the ADA Standards for Accessible Design, latest edition.
11. Typical details for attaching wall-hung fixtures to walls
12. Whether piping is run above or below ground, floors, and ceilings and whether concealed or exposed
13. Capacity and operating characteristics of each item of equipment
14. Locations and details for special supports for piping
15. Locations, sizes, and types of cleanouts
16. Locations, sizes, and typical details for extended rim floor drains
17. Detail or sections through each type roof drain, floor sink, and grease interceptor or separator
18. Roof drain/roof leader piping location and sizes
19. Location of acid-resistant DWV piping, cleanouts, traps, drains and accessories
20. Cleanouts in crawl spaces or exterior of buildings shall be not less than 3 feet from building wall
21. Exterior buried piping shall not run parallel within 5 feet of exterior building wall
22. Location and size of water hammer arresters
23. Ranges and accuracies for gages and thermometers
24. Capacity, size, bypass valves, and piping for water meters and detail of water meter box (coordinated with serving utility entity)
25. Locations and sizes of access panels for valves
26. Details of pipe penetrations in outside walls

2.7.7.17 Mechanical (HVAC) Drawings

1. Indicate items to be demolished as part of renovation projects.
2. Provide plans of each floor and roof indicating double line-duct layouts and mechanical equipment. Plans shall indicate ceiling-mounted lighting fixtures.
3. Provide plans for each floor indicating chilled water, heating hot water, steam and condensate piping and piping sizes. Show provisions for expansion. (This may be shown on ductwork plans when legible.)
4. Provide layouts of mechanical equipment and fan rooms to a scale not less than twice that of the floor plans. Show equipment, ducts and piping to coordinate the installation in tight areas. Show access and service space requirements such as that required for tube, coil, and fan removal.

5. Provide schedules for all mechanical equipment, steam traps, and air devices, showing sizes, capacities, horsepower, CFM, electrical characteristics, locations and features.
6. Provide drawings showing control schematics and automation points.
7. Provide diagrams of chilled and heating water, steam, and condensate piping.
8. Indicate central heating and cooling plants, distribution piping, equipment, anchors and expansion joints.
9. Provide sections as required to clearly show the work in 3 dimensions.
10. Indicate the building heating loads (in Btu or pounds of steam per hour) to include transmission plus infiltration, outside air, domestic hot water, and kitchen, laundry, hospital hot water and outside air loads.
11. Indicate the sensible and total air conditioning cooling load of the building in tons. Also show the outside air portion of the cooling load in tons.
12. Indicate fitting types for ducts.

2.7.7.17.1 Mechanical Insulation

Show the following information on the project drawings:

1. Areas where pipe insulation differs from the typical;
2. Areas where ductwork is to be internally insulated;
3. Areas where metal jackets are to be used on interior piping;
4. Pumps to be insulated and encased in 20 gauge boxes, if required;
5. Heat exchanger temperatures.

2.7.7.17.2 Central Refrigeration Equipment for Air Conditioning

Show the following information on the project drawings:

1. Indicate size and locations of cooling tower supports.
2. Locations of water treatment tanks and control panels.
3. Indicate size and routing of refrigerant safety relief discharge piping. Consult ANSI/ASHRAE 15 Safety Code for Mechanical Refrigeration.
4. Indicate a cooling tower basin heating system for cooling towers that will be required to operate when outside temperatures are below freezing and the heat generated through the refrigeration process (with head pressures maintained) will be insufficient to preclude freeze-ups. Either electric immersion heaters or steam or hot water coils may be used for supplemental heating.
5. Indicate vibration isolation requirements.

2.7.7.17.3 Air Handling Equipment

Show the following information on the project drawings:

1. Arrangement plan and details for air handling equipment and accessories.
2. Equipment schedules with sound ratings (loudness level), electrical characteristics, capacities.
3. Equipment pads, foundations, supports, and vibration isolators.

2.7.7.17.4 Temperature Control Systems

Show the following information on the project drawings:

1. Sequences of operations and system schematic. (Specification should contain a narrative description detailing how the controls are to operate.)
2. Direct Digital Controller (DDC) architecture schematic: Show general architecture of DDC system including controllers, communication LANs, workstation terminal, etc.
3. Dampers: Show type of damper (opposed or parallel blade).
4. Control valves: Show control valve nominal size, flow capacities, type of fluid, inlet pressure, maximum and minimum pressure drop at design flow, and calculated Cv. (Select valves for smallest Cv within available pressure constraints, pipe velocities, economy of design, and noise criteria.)
5. Indicate pressure and temperature indicator's scale ranges and location. Location of temperature wells and pressure taps.
6. Smoke detectors and location of key-operated override switches, when required, along with the zoning arrangements for these systems.
7. Indicate location of meters provided in this and other sections.
8. Location of room sensors, pressure sensors and outdoor sensors.
9. Input/output summary as described in the Manual.
10. Location and horsepower of air compressors and refrigerated air dryers when required.
11. Elementary wiring diagrams.
12. Location and types of automatic dampers, including smoke dampers, e.g., opposed or parallel blade.
13. Mechanical flow drawing: Show relative position of all individual HVAC components, input sensors (temperature sensors, pressure sensors, equipment proofs, override buttons, etc.), output components (actuators, valves, dampers, etc.), and hardwired safeties (smoke detectors and freeze stats).

2.7.7.17.5 Testing/Adjusting/Balancing: Heating, Ventilating and Cooling Systems

Show the following information on the project drawings:

1. A unique number or mark for each piece of equipment or terminal.
2. Air quantities at air terminals in CFM and direction of air flow (2-way, 4-way, etc.).
3. Air quantities and temperatures in air handling unit schedules
4. Water quantities and temperatures in thermal energy transfer equipment schedules.
5. Water quantities and heads in pump schedules.
6. Water flow measurement fittings and balancing fittings.
7. Ducts for special locations (wet, corrosive, etc.)

2.7.7.18 Electrical Drawings

Power and lighting plans may be combined if the combined drawing clearly conveys required information.

1. Provide lighting plans for each floor indicating fixture location, type and lighting level required (in foot-candles).
2. Provide power distribution plans indicating incoming service, generators, panelboards, etc., and outlines of mechanical equipment (for coordination.)
3. Indicate interface points for communications, fire alarm, and EMCS.
4. Provide floor plans indicating receptacles, telephone outlets, switches, audio visual and data.
5. Indicate, in kilowatts or kVA, electrical load total, three-phase load, motor load and size of largest motor in horsepower.
6. Provide control diagrams, panel board schedules and riser diagrams.
7. Provide lighting fixture schedule on the drawings.
8. Provide layouts of electrical rooms at a scale not less than twice that of the floor plans. Show all required clearances. Show required door swings.
9. Doors to electrical rooms shall be provided with permanent signage reading "NO STORAGE" in letters not less than the room identification or the working space as defined by NEC shall be marked by a 2" wide yellow line and stenciled "NO STORAGE - ELECTRICAL WORKING SPACE" in 2" high yellow letters in mechanical rooms, electrical rooms, and service areas.

10. Provide layouts of elevator machine rooms at a scale not less than twice that of the floor plans. Show all equipment and required clearances for coordination.
11. Provide details to include duct bank, under/through footing penetration, housekeeping/equipment pads, lighting switching, grounding details for service entrance and individual transformers.
12. Provide grounding riser diagram for generators, transfer switches, main-tie-main switchboards and separately derived systems.

2.7.7.18.1 Interior Wiring and Circuiting

Show the following information on the project drawings:

1. Plans showing locations of all fixtures, receptacles, switches, and outlet sizes.
2. Show Branch Circuiting with identification of circuits for all light fixtures and switches. Show wire size, type insulation, method of running circuit, and number of conductors including ground fault protection, as applicable.
3. Provide panelboard schedule for branch circuits.
4. Show conduit sizes and runs.
5. Show mounting height for outlets and switches on elevation or note on drawings.
6. Have equipment rooms and electrical rooms been checked for adequate heat dissipation (e.g., cooling or ventilation)?
7. Are wiring and equipment suitable for kitchens, mechanical rooms and other hot locations?
8. Are voltages, loads and characteristics of electrical powered equipment compatible with the service provided?
9. Have conduit stub-outs and circuiting been shown/located for future planned needs?

2.7.7.18.2 Service and Distribution

Show the following information on the project drawings:

1. On electrical site plan, show location of service to property and overhead or underground routing of service to building. Show transformer location, if applicable, and service entrance location.
2. Show service cable size and type (aluminum or copper) wire.
3. Show ground service and tie to protective ground.
4. Show single line main power riser diagram from service entrance to distribution panelboards.

5. Connection of equipment should be indicated by circuit runs. Indicate type of insulation, wire size, number and type of conductors for feeders including equipment ground and ground fault protection.
6. Indicate wiring and raceway requirements. Provide elevations of switchgear arrangements, the motor control centers, and the control switchboard.
7. Show ratings for buses, instrument transformers, relays, instruments, circuit breakers, motors, motor controllers, lighting transformers and other requirements not covered in the specifications.
8. On electrical power floor plans, show location and identification number of main panel and of distribution panelboards.
9. Show panelboard schedules to include size, rating, circuit breaker ratings, class and number of poles, terminals and equipment ground.
10. Verify that sufficient space exists to install panelboards in locations as indicated.
11. Verify that panelboards are not improperly recessed in fire rated walls.
12. Disconnects shown for motors and electrical powered equipment
13. Has spare capacity (25%) been included in all mains and panelboards?
14. Have structural supports been designed and shown for electrical equipment, masts, and such?

2.7.7.18.3 Interior Lighting

Show the following information on the project drawings:

1. Type, style, mounting, lamp arrangement, ballast type, power factor and lumens per watt. Use schedule if necessary.
2. Location of fixtures on plan. Coordinate with reflected ceiling plan.
3. Wattage, voltage, and frequency rating required
4. Type of reflector, diffuser required
5. Glass/plastic lens
6. Accessories required, such as photocell, time switches and auxiliary lamps
7. Mounting height above floor or grade to bottom of fixture
8. Indicate type of rods or straps used to suspend fixtures if more than one type of hanger is used.
9. Reflecting or non-reflecting surface finish
10. Shielding required
11. Exit and emergency lighting shown for corridors, stairs and egress routes.

2.7.7.18.4 Exterior Lighting (and accessories)

The following information shall be shown on the drawings or included in the project specifications:

1. Luminaire schedule indicating pertinent information (mounting, lamps, ballasts, and voltage).
2. Type of luminaire;
3. Voltage and wattage rating required;
4. Accessories required, such as photocell, time switches, and auxiliary lamps;
5. Location of poles or standards;
6. Referenced sketch; and
7. Extent and location of the work to be accomplished and wiring and equipment necessary for a complete installation.
8. Detail of pole base and foundation including anchorage and grounding

2.7.7.18.5 Communication Systems

Show the following information on the project drawings:

1. On electrical site plan, show location of service to property and overhead or underground routing to building.
2. Show location and size of communications equipment mounting board.
3. On electrical power floor plans, show location of control panel
4. Show single line communications riser diagram. Connection of equipment should be indicated by circuit runs in lieu of conduit runs. Do not indicate number and size of conductors for interconnection of communications components.
5. Show mounting height for outlets on elevation or note on drawings.

2.7.7.18.6 Generators

Show the following information on the project drawings:

1. Verify that general information and data below has been shown:
 - a. Piping plans and elevations.
 - b. Fuel Piping and tank details.
 - c. Engine setting plan and details.
 - d. Civil; architectural; structural; heating, ventilating, and air conditioning; plumbing; and electrical plans and details.
 - e. Flow Diagrams indicating the number of engines and other system requirements.

- f. Diagrams indicating sizes of all piping not provided by the engine manufacturer.
 - g. Indicate any additional specified water treatment requirements.
2. One-Line Diagrams:
 - a. Indicate the number of engine-generator units and other system requirements.
 - b. Are wiring and raceway requirements shown?
 - c. Are elevations of switchgear arrangements, the secondary unit substation, motor control centers and the control switchboard shown?
 - d. Are ratings for buses, instrument transformers, relays, instruments, circuit breakers, motors, motor controllers, lighting transformers and other requirements shown or covered in the specifications?
 3. Miscellaneous: Provide any limiting dimensions, not covered in the specifications, by codes, or defined on to-scale drawings, which are necessary for proper system operation.

2.7.7.19 Control Systems

1. Provide a written sequence of operation on the plans for each mechanical and electrical control system stating explicitly how systems are intended to function.
2. Provide data regarding safety, alarms, indicators and control parameters.
3. Provide control system input/output summaries.
4. Indicate point(s) of connection of new to existing system.
5. Indicate location of operator interface.

2.7.8 Project Specific Specifications

Specification sections shall be written/edited to apply specifically to the project and shall not include materials, standards, requirements or data not pertaining to the project. Specifications shall conform to the requirements and standards listed in DCSM section 1.5.4.

2.7.9 Rock Excavation

See DCSM section 7.9.6 for requirements. Provide estimated quantities of rock excavation on the Bid Form.

2.7.10 Submission

The A/E shall prepare and submit working drawings and specifications for the University to submit to the various review agencies for approval as pertinent to the project. (See DCSM section 1.5.1.)

2.7.11 Time for Completion

With this submission, the A/E shall furnish the University with an estimate of the time for constructing the project and include such in the appropriate paragraph of the bid form.

2.8 DOCUMENT RETENTION REQUIREMENTS

The University is responsible for assembling, maintaining and retaining the record construction documents for University buildings. This includes documentation of all renovations, remodels and additions.

These documents shall be provided to the University electronically in PDF format. The University may also request additional copies of the record documents in other formats at its discretion.

The Record Documents include the Record Drawings of the as-built plans, specifications, maps, submittals, shop drawings, and other pertinent documents. These documents shall be retained until the building is removed from the state inventory. At that time the University shall contact the State Archivist at the Library of Virginia to determine the disposition of the documents. The University is responsible for records retention in accord with the applicable Library of Virginia Records Retention Policy.

CHAPTER 3 - SAFETY AND SECURITY

Safety and security equipment as described in this chapter cannot be removed from the project requirements as a result of Value Engineering.

3.1 FALL PROTECTION

Passive fall protection systems should be installed on roofs and other locations such as mezzanines, where the fall distance to the next lower level is greater than 30 inches, whenever feasible.

Passive fall protection shall be provided on exterior grounds where one grade is more than 30 inches above an adjacent grade and they are connected by a vertical or near-vertical slope. Landscaping shall not be permitted to guard a fall hazard area unless approved by EHS.

Where mechanical equipment is installed on roofs, it should be located inside penthouses, behind screens, within a parapet wall of sufficient height, or behind permanent guardrails, when possible. If mechanical equipment is not located behind or within an enclosure, and is located within 15 feet of an unguarded edge, the edge shall be guarded in accordance with 304.10 of the Virginia Mechanical Code.

1. Passive Fall Protection Systems
 - a. Parapet wall height at least 39" from the walking/working surface
 - b. OSHA-compliant guardrails
 - i. Top rail 42" +/- 3" from ground/walking surface, and withstands 200 lb. of force applied in an outward and downward direction.
 - ii. Mid-rail approximately halfway between top rail and ground (about 21") from ground/walking surface, and withstands 150 lb. of force applied in an outward and downward direction.
 1. If vertical, intermediate members (e.g., balusters) are installed between the top rail and walking/working surface, they shall not be more than 19" apart.
 2. Other structural members, such as additional mid-rails or architectural panels, shall not have an opening more than 19" apart.
 - iii. Toe-boards installed where materials can fall off of the elevated walking/working surface onto personnel below. They should be 3½" in height, and no more than ¼" above the walking/working surface, and withstand 50 lb. of force applied in an outward direction.

- c. Standard guardrails
 - i. Penetrating (roof): Permanently mounted
 - ii. Non-penetrating (roof): Free-standing
- d. Low-profile (reduced visibility) guardrails (setback, curved)
 - i. Penetrating (roof): Permanently mounted
 - ii. Non-penetrating (roof): Free-standing
- e. Collapsible guardrails
 - i. Penetrating (roof): Permanently mounted
 - ii. Non-penetrating (roof): Free-standing
- f. Temporary guardrails
 - i. Penetrating (roof), install/store as needed: Permanently mounted, low-profile base plates installed on roof, temporarily add rails when accessing roof
 - ii. Non-penetrating (roof), install/store as needed
 - 1. Clamp to parapet wall
 - 2. Install base/mount to wall/short parapets
 - 3. Free-standing
- 2. Active Fall Protection Systems
 - a. Where passive fall protection systems are not feasible on roofs or penthouses, permanent anchor points specifically designed for fall arrest, and meeting OSHA requirements, should be provided.
 - i. Bollards/anchor points designed to withstand 5,000 lb. per attached person.
 - ii. Travel Restraint Systems with 100% tie-off
 - iii. Horizontal Life Lines
 - b. Where permanent anchor points are not feasible, mobile anchor points as approved by Facilities Services and Environmental, Health and Safety shall be provided.
 - i. Designed for permanent, long-term installation
 - ii. Designed for temporary, short-term use
- 3. Skylights shall be sufficiently guarded in accordance with 29 CFR 1910.28(b)(3)(i).

3.1.1 Elevated Walking/Working Surface Access

- 1. Stairway and door access to roofs and other elevated working or accessible storage surfaces is preferred over fixed ladders, roof hatches, or temporary means of access (e.g., extension ladders).
- 2. Handrails shall be provided for stairways per Table D2 of 29 CFR 1910.28(b)(11).

3. Handrails shall be provided for exterior stairs associated with walkways in accordance with 1910.28(b)(11), or the VCC, whichever is more restrictive.
4. Roof hatches should have guardrails on each side.
 - a. A self-closing swing gate should be provided at the access point.
 - b. Grab-rails should be provided at the roof level if they are not integral with the roof hatch system.
5. Mezzanines shall have the designated load-rating posted.
6. Fixed Ladders
 - a. New fixed ladders, that extend more than 24 feet above a lower level, must have a personal fall arrest system or a ladder safety system installed.
 - b. Ladder Safety Systems selected shall be consistent with existing systems installed on campus, or as approved by Engineering Operations and Environmental Health and Safety.
 - c. Cages or wells are no longer permitted on new installations after November 19, 2018, or on existing installations after November 18, 2036.
 - d. Fixed ladders must have a swing gate or be offset at the point of access to prevent falls.

3.1.2 Floors/Ramps

Flooring must have a dynamic coefficient of friction (DCOF) of at least 0.42. Some applications may require a higher DCOF depending on use, expected traffic and wear, contaminants, maintenance, and manufacturer guidelines. The use of floor coatings to achieve this coefficient of friction is permitted, but not preferred.

Entryway walk-off systems shall be provided at all regularly used, exterior-to-interior entrances and entrances from covered parking garages. Walk-off carpet tiles or recessed mat/grate systems are preferred in lieu of removable roll-out mats.

3.2 SAFETY EQUIPMENT NOT REQUIRED BY CODE

Safety equipment, including fire detection, fire alarm, and fire suppression systems, which are not required by code, but are provided at the University's option in buildings and structures shall be installed in accord with the code and shall operate as designed. Work that is planned as a complete system, but requires phased construction to provide a complete system is acceptable. It is also acceptable to provide non-required, fully functional "partial systems" to certain areas (e.g., storage spaces) which will improve safety. However, incomplete systems

which are not designed in accord with the code, non-functional systems and abandoned life safety systems are not acceptable because such systems may be perceived as code-compliant systems and may result in life safety or fire hazards to adjacent areas.

3.3 EMERGENCY AID SPECIALTIES

Automatic External Defibrillator (AED): Install sufficient number of AEDs to provide a 3-minute response time. Place AEDs in central locations in buildings.

Provide AEDs (typically one per floor) to:

1. Service public areas such as lobbies, hallways, entryways, high visibility pedestrian collection points, areas of high pedestrian concentration, areas of frequent large populations;
2. Be visible to the pedestrian public by locating cabinets in line of sight paths;
3. Be equipped with signage adequate to reasonably alert the public of AED locations;
4. Be placed in areas where service technicians can gain access without specialized permissions, access cards, or in restricted research areas without prior approval of the Rescue Squad; and
5. Be placed on walls or contained within a recessed cabinet without potential to be covered by furniture, wall decorations, or equipment.

The location of defibrillators shall be coordinated and approved by Virginia Tech Rescue Squad.

AEDs purchased for Virginia Tech shall be the Zoll AED Plus Model semi-automatic external defibrillator. The product package includes the AED, quick response kit, protective case, two batteries, two adult defibrillation pads, wall sign, and a theft-resistant wall cabinet.

3.4 EXTERIOR ACCESS

A Knox Box shall be placed on the exterior of the building. The Knox Box shall be Knox-Vault (Series 4400, P/N 4486, silver finish, recess mount, 6" depth with a dual lock key). Mount unit 6 feet above finish grade and locate near the building's front entrance, typically by the fire panel. The exact location shall be determined by the Fire Department. The Knox Box should have the appropriate keys inside upon completion and opening of the building.

3.5 DOORS AND WINDOWS

Doors and windows have the following safety requirements:

1. Exterior Doors, Stairwell Doors, and Hallway Doors:
 - a. All egress double doors shall not have the potential to be chained. When viewing from the outside, the left hand door shall not have a handle, only the right side may have a handle. On the inside, panic/push bars shall have no gap behind (between bar and glass, or bar and door).
 - b. These doors should provide unfettered egress, but should also make it not possible to lock them from the outside.
 - c. The inside should have push bars (not handles). The outside should have only one of the two door sets with handles to open (alleviates the chaining of handle to handle). The locks should be set to the store room function.
 - d. In addition, caution should be used that nothing else in the area of the doors provides a means of locking/chaining them from the outside or inside.
2. All interior classroom doors, conference rooms, and offices shall have a manual lock on the inside.
3. Interior Glass:
 - a. Interior glass that would allow access to classroom or office space shall be covered with an impact-resistant coating. This would include large windows viewing into occupied spaces from corridors, as well as windows on access doors that could be broken out to access interior locking mechanisms.
 - b. The coating or window film selection should meet the requirements set in ANSI Z97.1-2015 standard.
 - c. Interior window shades are recommended for interior glass walls for securing in place. Open view and open concept areas separated by glass limit occupant ability to secure in place during a campus incident.

3.6 EXTERIOR LIGHTING

1. OUP and VTPD shall be consulted on the design and color temperature of all exterior lighting.
 - a. Exterior lamps shall be LED.
 - b. Neon and/or cold cathode lighting systems are not permitted for use in exterior lighting systems.
2. Exterior light sources should be of a white source.
 - a. The Color Rendering Index (CRI) is important for normal pedestrians and the natural and perceived surveillance of the building.

- b. In addition, any future plans for surveillance cameras shall require white light sources for color imaging (i.e., color video surveillance cameras require a much higher CRI).
 - c. The CRI of white sources go from 80 up.
 3. With exterior lighting, the lighting recommendation for pathways and parking lots are referenced in the ANSI/IES RP-8-18 standard. Parking lot area lighting and sidewalk area lighting shall be addressed to ensure sufficient lighting to meet the recommendations. Coordinate parking lot specific lighting requirements with the Virginia Tech Police Department (VTPD) and the VT PM.
 4. For Roadway, Parking Lot, signage and Pedestrian “Hokie” lighting, see DCSM sections 4.4 and 4.7.14.7.

3.7 ELECTRONIC SAFETY AND SECURITY

3.7.1 Access Control

Electronic access (Hokie Passport) is required on all of the exterior doors. Infrastructure should be included regardless. See DCSM section 5.7.3.

3.7.2 Video Surveillance

1. Buildings shall have all necessary infrastructure and exterior features for the placement of surveillance cameras. All sides of buildings shall be included in the surveillance camera design layout. Exterior camera placement typically includes rooftop locations to provide maximum coverage of the area under surveillance.
2. Exact locations of surveillance cameras shall be coordinated with and approval obtained from VTPD and the specialty contractor for cameras. Coverage required for sites and the placement of cameras will vary. Vendor shall provide assistance during the design phase.
3. For exterior camera placement, the A/E shall incorporate the following:
 - a. Provide 360° exterior coverage.
 - b. Provide coverage of crosswalks, intersections, and major roadways. Complement existing coverage.
 - c. Provide coverage of areas with higher concentrations of people (common areas and areas with enough space for people to gather together).
 - d. Provide coverage of ingress and egress points from a lower viewing angle; typical placement would be above a portal or on the side of a building.
 - e. Provide coverage of high value assets.

- f. Provide coverage of loading dock areas for asset protection and intrusion prevention.
4. Exterior camera placements can be supplemented with cameras mounted on new Blue Light Phone placements, if those are part of the project.
5. For interior camera placement, the A/E shall incorporate the following:
 - a. Provide coverage of areas with higher concentrations of people (common areas and areas with enough space for people to gather together).
 - b. Provide coverage of high value assets.
 - c. All elevator cabs located in residence halls shall be installed with a security camera.
6. The infrastructure for surveillance cameras shall be installed in the hallways and stairwells for future camera installations.

3.8 COMMUNICATIONS

When required by the current adopted version of the VUSBC, all occupiable structures shall have a distributed antenna system as needed in the building for Police, Fire, and Rescue personnel and it shall be monitored by the fire alarm system. Regardless of whether a distributed antenna system is required per code, the A/E shall design a complete system for the building during the schematic and preliminary design phases. This should include, at a minimum, the locations of the interior and exterior antennas, major cable pathways, interior amplifier(s), and battery backup(s). Coordinate locations and design elements with the VT PM and the distributed antenna system vendor as part of the design.

Emergency Preparedness signage: Provide ADA compliant location and install 2" × 2" posters under plexiglass. This signage will be provided by the Office of Emergency Management (OEM). OEM signage locations shall be considered when laying out floor plans.

3.8.1 Mass Notification System

Emergency Notification System – The location of message boards and/or addressable fire annunciator system shall be approved and closely coordinated with the OEM. Emergency message boards should be located in both classrooms and common spaces. The Contractor shall provide and install conduit and power to the approved locations. Virginia Tech Network Infrastructure & Services (NI&S) shall provide the data cable and message boards.

Fire Alarm Annunciators – fire annunciators with public address systems/speakers are required.

VT Alert Message Boards – In buildings with Annunciators capable of providing VT Alerts, message boards are to be located in suitable common spaces providing redundant delivery of emergency messages. Coordinate message board locations with VTPD and the VT PM.

3.8.2 Emergency Telephone and Enclosures

1. A number of “push-to-talk” emergency phones may be located within the project limits. Infrastructure shall be designed to provide for emergency phone usage.
2. It is recommended that Emergency Callbox(s) be placed outside of the building.
3. The number and location of the phones is determined by OEM and the VTPD. The physical requirements for the infrastructure to support the phones are found in the following specifications and the drawing below.
4. For placement of Blue Boxes (interior emergency phones), the A/E shall incorporate the following:
 - a. Each floor shall have emergency phones. Exact number depends on floor plan and floor square footage and shall be coordinated with the VT PM and VTPD.
 - b. Phones shall be located along paths of egress to exits and stairwells. Longer floors or hallways may require additional boxes.
 - c. Phones shall be visible, but not located in areas where heavy traffic would lead to accidental activation.
 - d. Exact locations for phones shall be coordinated with and approval obtained from VTPD.
5. For placement of Blue Light Phones (exterior emergency phones), the A/E shall incorporate the following:
 - a. Phones shall be placed in projects to supplement the overall deployment. The A/E shall review the campus map for placement locations.
 - b. Phones shall be located in primary travel paths for pedestrians.
 - c. All new phone installations shall include camera placement capability.
6. Any emergency phones removed during a construction project shall be replaced as close as possible to the original location. Changes to the location or quantity of emergency phones within the structure should be approved by OEM and VTPD.
7. Equipment and materials used shall be standard components that are manufactured and available for purchase as standard replacement parts as long as the product is commercially available from the manufacturer.

3.8.2.1 Quality Assurance

1. All tower installation, configurations, setup, program and related work shall be performed by electronic technicians thoroughly trained by the manufacturer in the installation and service of the equipment provided.
2. The tower shall be warrantied against any defects in material and workmanship under normal use for a period of five years from date of installation, provided that manufacturer receives a completed "Installation Certification" certifying the date on which the system has been installed. An "Installation Certification" card shall be enclosed with every unit. In the event that no "Installation Certification" is received by manufacturer, the five years will commence on the date of shipment by the manufacturer.
3. The blue light and faceplate light shall be warrantied against any defects in material and workmanship under normal use for a period of 24 months from date of installation, provided that manufacturer receives a completed "Installation Certification" certifying the date on which the system has been installed. An "Installation Certification" card shall be enclosed with every unit. In the event that no "Installation Certification" is received by manufacturer, the 24 months will commence on the date of shipment by the manufacturer.

3.8.2.2 Certifications and Standards

1. The tower as an assembly shall be certified to UL Standard 60950-1. The basis of design for the tower shall be Talk-A-Phone model: ETP-MT.
2. The included LED blue light (the basis of design for the LED blue light shall be Talk-A-Phone model: ETP-EL or ETP-EL12/24) shall be certified to:
 - a. UL Standard 1598
 - b. CSA Standard C22.2 No. 250.0

3.8.2.3 Products

The tower shall consist of a highly vandal-resistant free-standing steel emergency phone tower mount with an integrated flashing LED blue light. Have an integrated LED faceplate light, mounted directly above the phone faceplate.

3.8.2.3.1 Hardware

1. The tower shall:
 - a. Be constructed of 0.25" thick steel and weigh approximately 300 lb.

- b. Measure:
 - i. Tower only: 10" W × 8" D × 108" H, with a 0.5" radius on each corner.
 - ii. Tower and Blue Light: 10" W × 8" D × 114" H.
 - c. Utilize a high-gloss, multi-coat, corrosion-inhibitive coating that shall be applied to withstand prolonged exposure to hard environments.
 - i. Tower shall be sandblasted to SSPC-SP 6 standards before a 2-3 mils layer of rust-inhibitive primer is applied.
 - ii. Tower shall be hand sanded for smoothness before a second 2-3 mils layer of primer is applied.
 - iii. Tower shall have a 2-3 mils layer of dark bronze color coat applied.
 - iv. Tower shall have a 1-2 mils layer of clear coat applied.
2. The tower base plate shall:
 - a. Be 2.0" above the tower base.
 - b. Be constructed of 0.75" thick A36 structural steel.
 - c. Have a 4" diameter center hole for wiring access.
 - d. Have four 1" holes for anchor bolt attachment.
 3. The tower wiring access opening shall:
 - a. Measure 9" H × 6.75" W.
 - b. Be located 15" above the base of the tower.
 - c. Have a flush cover plate that shall:
 - i. Be constructed of 0.25" thick steel.
 - ii. Be held in place by two 1/4"-20 countersunk, tamper-resistant spanner screws.
 4. The tower shall have an opening in the front to accommodate flush mounting an emergency phone. The phone opening shall:
 - a. Measure 10" H × 6.75" W.
 - b. Have six self-clinching #10-24 stainless steel threaded nuts to mount the emergency phone.
 5. Directly below the tower phone opening, the tower shall have a section with a 30° downward slope from rear to front, spanning the depth of the phone opening to the full tower depth.
 6. The tower shall have the word "EMERGENCY" emblazoned on all four sides in 3.25" high reflective white letters. Custom lettering, sizes and colors are available.

7. The tower blue light shall:
 - a. Be mounted at the top of the tower with three #10-24 tamper-resistant spanner screws.
 - b. Have a polycarbonate refractor lens assembly with a prismatic pattern to increase visibility at greater distances.

3.8.2.3.2 Functionality

1. Blue Light
 - a. The LED blue light shall remain lit at all times.
 - b. The blue light shall automatically flash 78 times per minute when triggered by the emergency phone.
 - c. The blue light shall have an illumination rating of 209 lumens (peak).
 - d. The blue light shall retain 70% of its initial output intensity after 50,000 hours of operation.
2. Faceplate Light
 - a. The faceplate light shall remain lit at all times.
 - b. The faceplate light shall have a concealed, ultra-bright LED design.
 - c. The faceplate light LEDs shall have no less than 50,000 hour lifetime.

3.8.2.3.3 Power Requirements

The tower shall be powered by one of the following power sources:

1. 12VDC – Nominal: 9 watts
2. 24VDC – Nominal: 9 watts
3. 24VAC – Nominal: 9 watts
4. 120VAC – Nominal: 9 watts

3.8.2.3.4 Manufactured Units

The basis of design for the tower shall be a Talk-A-Phone ETP-MT Emergency Telephone Tower to match existing equipment specified by VTPD and OUP.

3.8.2.4 Installation

1. The Contractor shall carefully follow instructions in documentation provided by the manufacturer to ensure all steps have been taken to provide a reliable, easy-to-operate system.
2. All equipment shall be tested and configured in accordance with instructions provided by the manufacturer prior to installation.
3. The tower mounting shall be per manufacturer's specification.

4. Provide and install all necessary conduit pathway and infrastructure as noted in the drawing attached.
5. Telecommunications cabling to be installed by NI&S under separate contract.
6. Power to the telephone tower is to be provided by the Contractor under separate contract. Contractor shall consult tower manufacturer's recommendations for power requirements.
7. Conduit pathways including service/pull boxes locations are to be designed by the Contractor during site plan coordination.
8. Conduit pathway installation detail:

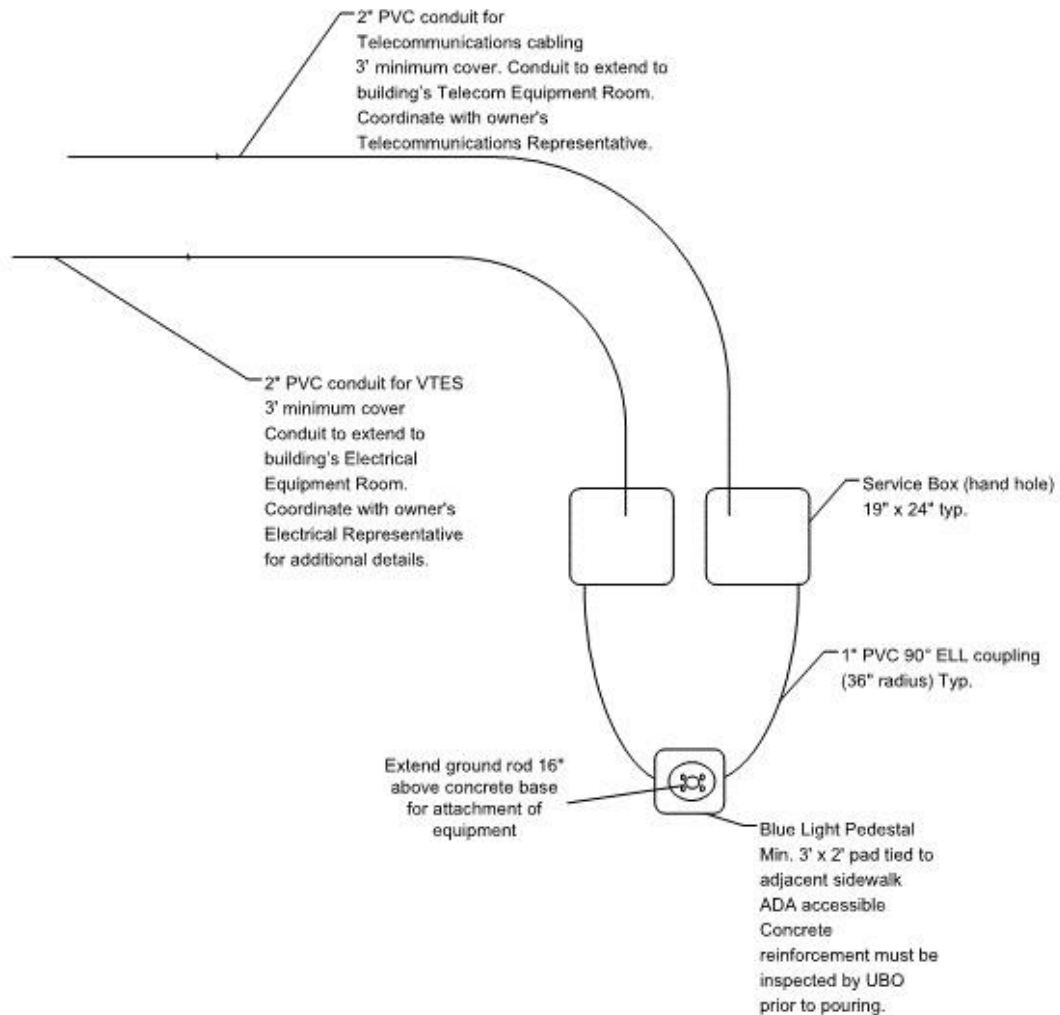

3.9 LABORATORY EMERGENCY SAFETY APPLIANCES

For additional laboratory design requirements, see DCSM section 5.18.

1. Eyewashes
 - a. Unobstructed access to an eyewash within 10 seconds is required in every chemical laboratory. Unobstructed is defined for this purpose as not being inside or outside of a door that can be locked or that would otherwise inhibit access. Unobstructed also means that no stairs, step-ups, etc., will need to be traversed in order to get to the eyewash or safety shower.
 - b. The design and installation of all eyewashes must meet ANSI Z358.1. Portable eyewash stations are not allowed.
 - c. Every new or renovated laboratory must include a plumbed eyewash installation.
 - d. Stand-alone eyewash stations or combination eyewash/shower stations must be plumbed to a drain in order to facilitate use and weekly testing (flushing) of the eyewash.
2. Safety Showers
 - a. Where the potential for contamination with caustic chemicals exists, a safety shower must be installed within 10 unobstructed seconds.
 - b. Safety showers must be installed in accordance with ANSI Z358.1. Where new buildings are designed or labs are renovated, ANSI Z358.1-2009 requires a water-mixing valve for tempered or a tepid supply of rinsing fluid.
 - c. Any new building with more than 15 safety showers in it shall utilize a central tepid water system with dedicated mixing valves and circulating pumps. Individual mixing valves at each showers in this situation are not an acceptable alternative.
3. Flow rates for eyewashes and safety showers shall conform to a functional test involving the fixture(s) on the floor that is farthest from the water supply. In accordance with ANSI standard Z358.1, flow rates for all new construction and major renovations shall be measured at 20 GPM. Existing eyewashes and safety showers shall have a minimum flow rate of 12 GPM.
4. See DCSM section 6.6.9 for floor drain requirements
5. Portable Fire Extinguishers: A portable fire extinguisher, suitable for use in the laboratory and around chemicals used therein, must be mounted in each laboratory. At minimum, a 10-pound ABC extinguisher will be required. Signage must also be displayed at the extinguishers. See DCSM section 3.10.4 for fire extinguisher cabinet requirements.

3.10 FIRE PROTECTION SYSTEMS

3.10.1 Fire Safety

3.10.1.1 Fire Protection Information Plan

Provide the information outlined in DCSM section 2.5.2 for schematic design submittals, DCSM section 2.6.2.8.8 for preliminary design submittals and DCSM section 2.7.7.15.1 for working drawing submittals. The requirements pertain to all projects which are constructed on state property, regardless of funding source.

3.10.1.2 Fire Safety Systems

The design of fire suppression systems (sprinkler systems/standpipes, alternate automatic suppression systems, fire pumps), fire detection and fire alarm systems, smoke control systems, access control systems and applied fire resistant materials shall comply with the submittal requirements outlined in DCSM section 2.7.7.15.2 through section 2.7.7.15.8. The requirements pertain to all projects which are constructed on state property, regardless of funding source.

3.10.1.3 Fire Safety Review of Shop Drawings

Shop drawings for the following building systems shall be reviewed and approved prior to the work being installed:

1. Fire suppression systems (sprinklers/standpipes, alternate automatic suppression systems, fire pumps): shop drawings prepared by a certified engineering technician, NICET Level III or IV, reviewed and approved as indicated below
2. Fire detection and fire alarm systems: shop drawings prepared by a certified engineering technician, NICET Level III or IV, reviewed and approved as indicated below
3. Smoke control systems designed by the licensed engineer, shop drawings reviewed and approved by the P.E. of Record, then reviewed and approved by the UBO
4. Applied fire resistant materials: product data and details prepared by the Contractor, as may be required by specific projects
5. Access control must be coordinated with fire systems by the A/E

The licensed professional engineer is responsible for the overall design of the fire protection systems, evaluating the building-specific conditions and preparing the analysis, calculations, design and

documents. When complete, the final documents display the signed, dated seal of the responsible professional engineer. Refer to DCSM section 2.7.7.15.

The certified engineering technician, certified to NICET Level III or IV, prepares the working plans as defined by NFPA 13, supplemental calculations, and material submittals based upon the engineer's design, for the engineer's review and approval. The professional engineer does not affix his/her professional seal to the shop drawings.

3.10.1.3.1 A/E Shop Drawing Final Approval

When the design of fire suppression, fire detection and fire alarm, smoke control, access control systems or applied fire resistant materials provided in the initial working drawings submittal is determined to be complete and code compliant by the UBO, then the Building Permit shall stipulate that the shop drawings and submittal data shall be reviewed and approved by the A/E of record.

The A/E shall include a stipulation on the working drawings and in the technical specification that the Contractor shall bid and install the fire protection system as shown in the documents. Designs modified from the UBO-approved Working Drawings, shall be submitted to the UBO for review and approval as described in DCSM section 3.10.1.3.

3.10.2 Protection During Construction

In renovation projects where the building is to remain occupied during construction, the following measures shall be included in the Contract Documents:

All existing fire protection systems shall remain operational during construction. If temporary shutdown is necessary, the system shall be returned to operational condition as soon as possible and no later than the end of each working day prior to the Contractor leaving the job site. The Contractor is to notify the SFMO prior to any necessary shutdowns. Any necessary shutdowns shall not affect other areas not involved with this construction project.

All operational standpipes are to be maintained at all times.

Sprinkler systems in areas being renovated shall be operational when the Contractor leaves the site each day. A fire watch shall be provided at all times that a sprinkler system is inactive.

3.10.3 Spray Fireproofing Design and Specification

3.10.3.1 General

1. Final Construction Documents shall clearly show locations, rating and type of spray fireproofing on the drawings, on typical and special details, and in the specifications.
2. The spray fireproofing applicator shall be qualified and/or licensed on the manufacturer product.
3. Proof of qualification and/or licensure shall be submitted to the University.
4. At the intersection of structural steel members with different thicknesses of spray fireproofing, provide spray fireproofing equal to the greater thickness on all members for a distance of 2' minimum from the intersection of the members.
5. Spray fireproofing shall meet or exceed the fire rating on all clips, hangers, light gauge framing, support sleeves and other attachments covered at the area of attachment to a structural member.
6. Mark new spray fireproofing with fire rating and material type in all accessible locations at 16' intervals.

3.10.3.2 Testing Requirements

All spray fireproofing shall be tested after installation according to manufacturer's requirements.

The University shall arrange and pay for services for field and laboratory tests and reports. The Contractor shall schedule the tests while the material is accessible. If additional tests are required as a result of non-compliance with the specifications, the additional tests and reports shall be paid for by the Contractor.

3.10.3.3 Removal and Replacement

The A/E, in consultation with the University, shall verify early in the design phase with the UBO the original purpose of any fireproofing material to be removed or replaced and what, if anything, must be done to restore the fire resistive characteristics.

Plans and specifications shall be submitted to the UBO, including any final construction documents, amendments/addenda, or change orders which may relate to the fire resistive characteristics of the structure. On every submittal, indicate construction date, original and present uses, height in

floors and feet, whether the building is sprinklered, and any other information that may assist the UBO in his/her determination.

If sprayed-on ACM is to be replaced, copies of the specifications for the intended replacement material shall be submitted to the UBO for review.

Independent testing laboratory reports shall be sent through the A/E to the UBO.

3.10.3.4 Identification of Spray-Applied Fire-Resistive Materials (SFRM)

New and replaced SFRM material shall be identified at 16' intervals in accessible locations with label providing the following information:

1. Fire rated assembly design number from listing agency.
2. Hourly rating.
3. Material type and designation.

3.10.4 Fire Extinguisher Cabinets

1. Fire extinguisher cabinets shall be incorporated into all projects. All fire extinguishers shall be installed in red, code-acceptable cabinets.
2. Fire extinguisher cabinet doors shall not be equipped with any type of lock. Only roller latches, or something providing an equivalent level of function shall be used. Access without a key is required for extinguisher inspection.
3. Fire extinguisher cabinets that are located in hallways or would be considered a protruding object per ADA requirements shall be either semi-recessed or fully recessed.

3.10.5 Fire Extinguishers

Contract specifications shall identify the extinguisher type and size and note that the extinguishers shall be provided and installed by the Contractor.

In general, all fire extinguishers shall be serviceable, 10-pound ABC type unless there is a special hazard present. If there is a special hazard present, then the fire extinguisher shall be listed for that specific hazard.

Permanent fire hoses are not acceptable for installation on campus.

3.10.6 Fire Alarm Systems

3.10.6.1 Overview

This section provides Virginia Tech's standards for the design and installation of fire alarm systems and equipment in new construction,

retrofit of new systems into existing buildings, and modifications to existing systems. All new University buildings shall be equipped with a fire alarm system with voice alarm capabilities meeting or exceeding these standards and applicable codes.

Over the years, Virginia Tech has developed a technologically advanced campus-wide fire alarm system through the standardization and integration of each new individual building system. These standards assure that each new system will have the proper technology to be fully compatible with the campus network, and to provide the level of fire protection the University desires.

In applying these standards to the design of a new system, designers are expected to follow everything listed without exception.

To determine the level of protection appropriate for a given type of building, several risk factors were considered. These were:

1. Building size – both the height and total area.
2. Building use – how the building is used and what hazards are present.
3. Occupant load – number of people occupying the building.
4. Type of construction – combustible, non-combustible, fire protected, etc.
5. Sprinkler protection – whether or not the building will be sprinklered.

A voice fire alarm system provides a public address function by use of the control panel microphone. This can effectively be used to communicate to all of the building's occupants for any type of emergency, even when building evacuation is not needed.

3.10.6.2 Design Phase Procedural Requirements

1. In designing Virginia Tech fire alarm systems, nothing in these standards shall be construed to allow anything less than full compliance with minimum legal requirements of the applicable codes and standards as established in the current edition of the VUSBC. Any discrepancies found should be brought to the immediate attention of the University.
2. The latest adopted edition of NFPA 72 shall be used for all new fire alarm systems. A code modification may be required from the UBO for required systems where the referenced edition in the VUSBC is not the most recent edition. The modification request is the responsibility of the University.
3. The communications protocol for the campus fire alarm network is proprietary to Johnson Controls. No other manufacturer's equipment can

be properly integrated into the network, and provide the two-way communication needed for monitoring and control of the existing systems. Therefore, all fire alarm equipment shall be listed as compatible with Johnson Controls. All suppression release (including kitchen grease hoods and server rooms) shall be by Johnson Controls.

4. As part of their service to the University, Johnson Controls provides a high level of engineering support to A/E's for the design of our new systems. A/E's are required to contact the Roanoke branch office of Johnson Controls for their assistance for every project. We rely heavily on input by Johnson Controls to assure compliance with codes and University standards, and for proper integration of new systems into the campus network. The A/E shall send Johnson Controls a copy of the set of preliminary design documents submitted to the University's internal review team.
5. Johnson Controls shall assist the A/E and the University by:
 - a. Providing Johnson Controls specifications to the A/E for their use.
 - b. Meeting with A/E and University to go over basic system design issues.
 - c. Reviewing working drawing design documents to assure system equipment is properly specified, and located within the building in compliance with codes and University standards.
 - d. Analyzing existing equipment impacted by any new installation to ensure that it can work properly with the new equipment.
 - e. Inspecting and testing new systems to help assure that the complete system is installed properly and performs in a manner compliant with code. Johnson Controls will send the CAD drawing files they have prepared showing final device locations to Environmental Health and Safety Services.
6. Provisions need to be made to update the campus fire alarm network when new systems are added. The TrueSite Workstation (TSW) in the Fire Protection Manager's office, the TSW in the Student Affairs Fire Protection maintenance office, and the appropriate Network Display Units necessary for sending the signals to the Central Station monitoring, must be reprogrammed to include building address, point label, etc., as needed to add the new system to the network.
7. The University's room numbering must be used to program the labels for the points in the control panel, and not the construction document numbers.

3.10.6.3 General Design Standards

1. All equipment shall be manufactured by Johnson Controls.
2. Control and Annunciator Panels
 - a. All displays and annunciators shall be the Info Alarm display.
 - b. Location of control panel – The fire alarm control panel (FACP) shall be located at the primary entry point to be used by the Blacksburg Volunteer Fire Department (BVFD) or in an electrical room. If the FACP is located in an electrical room, a Remote Command Center shall be provided at the primary entry point to be used by the Blacksburg Volunteer Fire Department. The University will provide this information to the A/E after consultation with the BVFD.
 - c. Remote annunciator panels shall only be used where two or more fire department response points are clearly identified. Otherwise, the main control panel or remote command center is all that is needed.
 - d. The FACP shall be used to control pre-action sprinkler systems. The panel must be UL listed or FM approved for this function.
 - e. Maximum mounting height of FACP shall be 75 inches above finished floor to the top of the 4100 panel.
 - f. Max limitation on power supplies – The design load placed on the power supply shall not exceed sixty percent of the power supply capacity.
 - g. Individual signal circuits shall not exceed sixty percent of the card capacity. For voice systems this assumes that all speakers are tapped at their maximum wattage, which is currently 2 watts.
 - h. Location of secondary panels – All secondary panels for the fire alarm system shall be located either in electrical closets or in public spaces where they are readily accessible.
 - i. All batteries associated with the fire alarm system shall be no more than three months old (based on the date code on the battery) at the time of system acceptance.
 - j. Batteries serving the FACP but installed in separate cabinets shall be located adjacent to the FACP and no higher than 3 feet above the floor.
 - k. Emergency power – Where a generator is present, the FACP and all secondary panels shall be tied to the emergency circuit, and batteries shall also be provided, sized per NFPA 72 requirements. Where there is no generator, batteries shall be provided and sized per NFPA 72 requirements as the secondary power source.

- l. If smoke control or stairwell pressurization systems are being installed, the FACP shall provide a manual means of activating and disabling these systems. Switches shall be clearly labeled as to the specific system they control.
 - m. If a building has stairwell pressurization fans and has emergency power generators, pressurization fans shall be on emergency power.
 - n. Degree of point reporting – All initiating devices shall be reported individually to the TSW and NDUs.
 - o. Network node – The panel shall be configured as a node on the campus Johnson Controls 4190 fire alarm network.
 - p. Provide all panels with a pair of fiber modems for each building system.
3. Initiating Devices
- a. Location of pull stations – Per code, unless existing conditions create installation problems where a reasonably safe alternative needs to be considered. All pull stations must be listed for the environmental conditions for the area of installation.
 - b. All pull stations shall be single action.
 - c. Addressable initiating devices – All devices shall be addressable type devices. All initiating devices must be listed for the environmental conditions for the area of installation.
 - d. Duct detectors – Unless required by code, are not to be installed on any air handling equipment. When duct detectors are installed the detector must be accessible for maintenance and a remote LED shall be placed on a wall or ceiling in public area where it will be readily visible and will not be obstructed by furniture, and shall be located as close as possible to the AHU. Signage shall be provided indicating the AHU served. Do not provide test switches.
 - e. For locations with an installed smoke or heat detector that would be affected by adverse environmental conditions or where maintenance on the detector would be problematic, aspirating early warning smoke detectors shall be used as an alternative to spot detectors.
4. Notification Devices
- a. Strobes shall be installed in conformance with NFPA 72. Strobes must be listed for the environmental conditions for the area of installation.
 - b. Ceiling mounted strobes are acceptable.
 - c. Location of strobes – All public spaces listed above for detection; and also, classrooms, bathrooms, laboratories, assembly spaces, conference rooms, shops with high ambient noise levels, mechanical

rooms and other areas as required by the VUSBC. Placement shall be made with consideration of ambient light levels.

- d. Synchronization of strobes – Strobes shall be synchronized and all strobes shall be the addressable type.
 - e. A/V unit mounting heights are dictated by the requirements for the strobe, not the speaker.
 - f. All speakers shall be tapped at their maximum capacity, which is currently 2 watts.
 - g. Ceiling mounted speakers are preferred.
5. Circuits and wiring
- a. Class B circuits shall be used.
 - b. Conduit vs. cable – For new construction, wire in conduit or EMT that is dedicated to the fire alarm system shall be used. For retrofit installations, the use of cable will be acceptable, but it must be installed in locations where it will be protected by building construction (above ceilings, in cable trays, chases, within walls, etc.) as long as the installation complies with the NEC.
 - c. Conduit shall be a minimum of $\frac{3}{4}$ ".
 - d. No conduit or EMT shall be run in or below slabs.
 - e. Wiremold may be used in retrofit installations, but only when it is in the project's scope.
 - f. All wire routed underground shall be listed for direct burial and be installed in conduit.
6. Interface with other fire protection systems and VT Alerts
- a. Mass Notification – To ensure the emergency notification to all members of the University community, the equipment necessary to connect to the University's Emergency Communication System (VTAlerts) shall be provided and installed to the building fire alarm panel. This will include two Ethernet ports installed in the building fire alarm panel.
 - b. Where the building contains other fire related systems, such as sprinklers, hood suppression, fire door hold-open devices, etc., these systems shall be connected to the new FACP and monitored for alarms, trouble, or supervisory conditions.
 - c. The A/E shall coordinate the sprinkler and fire alarm design to help assure that the number of flow; tamper and pressure switches are identified as accurately as possible in the working drawing design.
 - d. Where a fire pump is present, a "pump running" condition shall be treated as a supervisory condition, and not an alarm.

- e. Where dry-pipe valves are installed in buildings not normally occupied, where loss of heat in the room could go undetected, a means for monitoring the temperature of the sprinkler riser room shall be installed and programmed to provide a supervisory signal to the fire alarm panel.
 - f. A supervised tamper switch is required on all exterior post indicator valves on fire protection water supply lines. These valves are typically installed 40 feet from the building, which will require underground circuit be provided to the switch.
 - g. Every tamper and flow switch shall be individually addressed, regardless of their proximity to other devices.
7. Miscellaneous
- a. Consideration shall be given to any room within the building that may be subject to wash-down cleaning.
 - b. Devices shall be listed for conditions.

3.10.6.4 Building Specific Design Standards

1. Definitions of University Building Categories
 - a. Class 1 – Academic, administrative, assembly and research buildings (multi-story with elevator), or otherwise classified as such as needed to address specific safety concerns.
 - b. Class 2 – Residential buildings, all dormitories and Special Purpose Housing
2. Class 1 Building Specifications
 - a. Panel model – 4100ES or the latest version of this level of panel.
 - b. Type of audible devices – All notification audible devices shall be speakers.
 - c. Addressable audible devices – When addressable speakers become available from Johnson Controls, they are to be used.
 - d. Addressable strobes – Strobes shall be the addressable type.
 - e. Level of automatic detection – public area smoke detection shall be provided. This will include areas such as lobbies, hallways, reception areas, areas above every floor landing in all stairwells, elevator lobbies, NI&S communication closets, large electrical rooms containing either distribution transformers or switchgear, transformer vaults, the area at the FACP, storage rooms which are greater than 100 square feet, areas opening into a space without smoke detection, and areas that are neither sprinklered or nor enclosed by fire-rated construction.

- f. Specific areas that require heat detection – mechanical equipment rooms, attics and crawl spaces built with combustible construction, chemical storage rooms, shop areas used for welding, woodworking, painting, etc., or any other area with a hazard that warrants heat detection as determined by the University.
3. Class 2 Building Specifications
- a. All provisions for Class 1 systems shall apply, unless otherwise modified here.
 - b. All sleeping rooms shall be equipped with system smoke detectors with sounder bases programmed to function as a single station detector. This will satisfy the code requirement for single station detectors. If the detector is still in an alarm condition at the end of 60 seconds, the system shall sound a general alarm.
 - c. All detectors within a suite shall be programmed to operate the sounder bases simultaneously.
 - d. In addition to the public spaces listed for Class I buildings, strobes shall be installed in all suite living rooms, and in all bedrooms designed specifically to accommodate the disabled. Strobes shall be 110 candela in these bedrooms.
 - e. Heat detectors shall be installed in all residence hall student lounge kitchen areas and in locations where steam may be present.
 - f. All pull stations shall be equipped with alarmed covers to prevent vandalism. The basis of design for pull station covers shall be Lexan “Stopper II.”

3.10.6.5 Acceptance Testing and Warranty Period

1. As part of the final inspection and systems test, Johnson Controls will verify the candela rating of every strobe in its installed location, to ensure that the installing contractor has installed these devices per contract documents, and per code. A copy of this report shall be provided to the University’s Fire Protection Manager.
2. Johnson Controls will measure the sound level and clarity of the alarm signal, in all areas of the building, to assure that the installed system produces the signal volume as required by code. All intervening room doors shall be shut during the test. A copy of this report shall be provided to the University’s Fire Protection Manager.
3. Johnson Controls will provide the University with a written statement verifying the successful completion of all required tests. This document will be required at the time of substantial completion, before a

Certificate of Occupancy can be obtained for the building. A copy must also be provided to the SFMO.

4. Warranty period testing – During the one-year warranty period, two complete system tests shall be provided and included as part of the initial purchase of the system. The first test shall be done after six months from substantial completion, and the second during the eleventh month. These must be scheduled through the University's Fire Protection Manager.
5. Any time the Fire Alarm System is inspected and/or tested, a copy of the inspection/test report shall be provided to the University Fire Protection Manager.

3.10.7 Fire Suppression Systems

3.10.7.1 General Duty Valves for Water-Based Fire Suppression Systems

1. Sprinkler system control valves shall only be installed in corridors, stairwells, mechanical rooms, fire pump rooms and sprinkler valve rooms. The control valves shall be accessible with the use of no more than a six foot stepladder.
2. Provide minimum of 24" × 24" access door for valves located above inaccessible ceiling types.
3. Control valves shall not be installed, above or below ceilings in classrooms, offices, conference rooms or any dormitory living quarters.
4. Drain valves shall only be installed in corridors, stairwells, mechanical rooms, fire pump rooms and sprinkler valve rooms and shall be easily accessible. The drain valves shall be accessible with the use of no more than a six foot stepladder.
5. Drain valves shall not be installed, above or below ceilings, in classrooms, offices, conference rooms or in dormitory living quarters, or in any area requiring entry through a classroom, office, conference room or any dormitory living.
6. All drain valves discharge shall be piped to a drain capable of handling the discharge at full flow or to the exterior of the building.
7. Inspector test valves (ITVs) shall only be installed in mechanical rooms, corridors, stairwells, fire pump rooms, sprinkler valve rooms and custodial closets and shall be easily accessible. The ITVs shall be accessible with the use of no more than a six foot stepladder.

8. Inspector test valves shall not be installed, above or below ceilings, in classrooms, offices, conference rooms or in dormitory living quarters or in any area requiring entry through a classroom, office, conference room or any dormitory living quarters.
9. Inspector test valves discharge shall be piped to a drain capable of handling the discharge at full flow or to the exterior of the building.

3.10.7.2 Identification for Fire Suppression Piping and Equipment

1. Each control valve shall be supplied with signage indicating the area of the building that is served by the valve.
2. At all locations that inspector test valves or control valves are concealed above ceilings or behind access doors, a sign shall be provided on the ceiling below the valve or on the access door indicating the location of the valve.
3. Specifications shall indicate that following the completed installation, Virginia Tech Facilities Fire Protection Manager and their independent consultant will inspect and test all components of the installed sprinkler systems prior to final inspection and acceptance by the SFMO and report any deficiencies to the VT PM, the UBO and the SFMO.

3.10.7.3 Water-Based Fire Suppression Systems

1. In residential buildings, all control valves that are located in spaces accessible by the occupants of the building shall be provided with lockable tamper prevention devices and locks that shall be specified by the University.
2. In residential buildings, each fire department hose valve shall be provided with a lockable tamper prevention device and a lock.
3. No sprinkler heads from any manufacturer which incorporate a rubber O-ring shall be permitted to be installed in University buildings.
4. The stock of spare fire sprinklers shall correspond and the quantity be in proportion to the types and temperature ratings of the sprinklers in the property.
5. In residential buildings, provide concealed type sprinkler heads in all occupiable rooms.

3.10.7.4 Fire Suppression Hose Valves

In addition to building code requirements, in buildings where the floor level of the highest story is located more than 24 feet above the lowest level of fire department access, all stairways that have an exterior exit shall be

provided with standpipes and fire department hose valves on each intermediate level.

3.10.7.5 Fire Suppression Sprinkler Systems

1. Sprinkler system piping shall be steel; no plastic pipe shall be used.
2. In buildings with sprinklers, fire pumps and/or standpipes, separate water service for fire protection shall be provided, and shall not be through the domestic metered water service.
3. A digital set of as-built sprinkler system plans in AutoCAD® format (see DCSM section 2.4) shall be provided to the VT PM and shall include information for every individual sprinkler head location which identifies the manufacturer, model, temperature rating and date of manufacture for the head that was actually installed. In addition, a digital summary shall also be provided to the VT PM which lists all the individual types of heads installed for the whole building, and the total number installed of each type. It is the responsibility of the sprinkler contractor to verify in the field that the inventory accurately represents the heads that were actually installed. Reliance solely on the approved shop drawings is not acceptable.

3.10.7.6 Dry-Pipe Sprinkler Systems

All dry sprinkler system piping shall be at least schedule 40 galvanized pipe with cut grooves for couplings.

CHAPTER 4 - SITE DEVELOPMENT

4.1 LANDSCAPING

1. Landscape installation will be managed (procurement through installation and final inspection) by VT Facilities using plans and specifications provided by the project A/E. Some capital project landscape installations may be included in the General Contractor's scope of work.
2. Final stabilization and landscaping in all stormwater Best Management Practices (BMPs) shall be the responsibility of the Contractor in compliance with the VTAS&S.
3. All tree planting, removal, and maintenance shall meet standards set by ANSI Z133.1 Safety Standard and ANSI A300 Tree Performance Standards.
4. No trees shall be planted on a BMP embankment.
5. Bioretention planting shall be shrub-based with plants selected based on tolerance to flooding and drought and adaptability to the current bioretention soil specification. Perennials and ornamental grasses are not acceptable on the campus core. Lawn is an acceptable cover if embankments are less than 3:1 slope.

4.1.1 Landscape Planning Process and Implementation

1. Landscaping (and future growth of landscaping) shall not impact transportation site distance and shall be avoided within sight lines from 2 to 7 feet above the paved traffic route. See DCSM section 3.1 for restrictions on using landscaping as fall protection.
2. Follow the VT Core Campus Approved Tree Specimens list and the Woody and Herbaceous Plant list for development of the landscape plan. Any deviation from these lists requires approval from the University Arborist and the Campus Landscape Architect prior to plan submittal. Coordinate with OUP for the lists.
3. Project architect shall retain a Landscape Architect to provide the University with a complete landscape plan, details, and specifications to be included in the project bid documents, as well as a cost estimate.
4. The Landscape Architect must consult with the Campus Landscape Architect throughout the landscape planning process and as follows:
 - a. Conduct preliminary landscape planning meeting with the Campus Landscape Architect to discuss process and site issues influencing development of the landscape plan.

- b. Landscape Architect should consult the VT Campus Master Plan and the Campus Design Principles for the discussion of Landscape Guidelines prior to meeting with the Campus Landscape Architect.
- c. Coordinate plant selection through campus landscape architect.
- d. Coordinate landscape planning with building stake holders with assistance from the Campus Landscape Architect.
- e. Provide full landscape plans and specifications.
- f. Review landscape specifications with Campus Landscape Architect.
- g. For projects where the landscape installation is in the General Contractor's scope of work the following shall apply:
 - i. Project Landscape Architect must conduct a preconstruction meeting with the landscape subcontractor.
 - ii. Provide, at a minimum, an inspection of plant materials prior to install, and one or more inspections during landscape installation and a final landscape inspection/ punch list.
 - iii. Campus Landscape Architect and Facilities Building and Grounds must be included in plant material inspection prior to installation, and final inspection/ punch list inspection.
 - iv. Final landscape installation acceptance shall be by the Landscape Architect.
- h. For projects where landscape install is managed by VT Facilities Building and Grounds, Facilities will manage all preconstruction and inspection activities.

4.1.2 Landscape Design Considerations

Maintenance resources on campus are very limited. The landscape must be designed with this in mind. A landscape of predominantly long- lived shade trees with accents of flowering and evergreen trees is preferred.

To simplify maintenance, shrubs should be planted in masses, avoiding complicated/"fussy" multi-species arrangements while serving a specific function (screening, traffic control, unmowable slope cover, etc.).

Perennial beds should be severely limited and focused on high visibility areas such as main building entries.

Complicated, multi-species ground cover and perennial beds, ornamental grasses, etc., are not long-term landscape features and should not be included in the landscape plan.

4.1.3 Tree Protection and Preservation Procedures

For tree protection procedures, see the tree protection detail in the VT Design Standard Detail Library. Coordinate trees to be removed with the University Arborist and Campus Landscape Architect.

1. Preservation during design phase

On the site survey map, identify all trees whose root systems are likely to be impacted by construction equipment, cut and fill activities, utility corridors, proposed walks and roads, and potential construction staging areas; and whose branches may be damaged by construction equipment.

If trees are grouped in a forest or woodlot, then only the location of the woodlot and any trees greater than 24 inches diameter at 4.5 feet above the ground (the diameter at breast height or DBH) need to be identified.

a. Not salvageable

- i. All trees that are within the footprint or in close proximity to the footprint of a proposed building. Alternative footprints to save large, valuable trees should be considered, provided that the alternatives maintain the desired features and costs of the proposed building.
- ii. Trees of undesirable species or in very poor health. Examples include, but are not limited to species that have low landscape and educational value, and heavily diseased or damaged trees that have little chance of recovering desirable form and function, even if protected from construction damage.

b. Low priority for protecting

- i. Small trees (less than 10 inches DBH) that fall outside of the building footprint, but are likely to be impacted by construction activities.
- ii. Larger trees outside of the building footprint with relatively low landscape value. Examples include but are not limited to, trees with poor form, species of relatively low landscape and educational value, or trees with inadequate space to accommodate current or future growth even if the site is ameliorated.

c. High priority for protecting

Medium (> 10 inches DBH) to large (> 24 inches DBH) trees of desirable species with good form, good health, and room to continue to grow.

2. Avoid locating the general construction site around high priority trees where possible by:

- a. Planning all construction activities including new utility corridors, staging areas, new sidewalks and new roads for a minimum clearance of 15 feet

away from the base of trees, and not within the edge of the canopy drip line. Greater distances are desirable.

- b. High priority trees should receive more consideration than low priority trees in planning corridors, staging areas, walks, and roads.

4.2 PLANTING

OUP shall be consulted on all planting-related project components. Both the OUP and the University Arborist shall be consulted on all tree planting-related project components. See the VT Design Standard Detail Library for planting and tree protection details. The use of sod is recommended on all disturbed areas. Areas of focus include, but are not limited to:

1. Planting Preparation
 - a. [Soil Profile Rebuilding](#): This specification sheet is provided through the VT Urban Forestry website.
 - b. Mulching
 - c. Planting Soil Mix
 - d. Planting Beds
2. Turf and Grasses
 - a. Hydro-Mulching
 - b. Seeding
 - c. Sodding
3. Plants
 - a. Groundcovers
 - b. Plants and Bulbs
 - c. Shrubs
 - d. Trees
4. Planting Accessories
 - a. Landscape Edging
 - b. Tree Grates
 - c. Silva Cells
5. Transplanting
 - a. Groundcover
 - b. Plant and Bulb
 - c. Shrub
 - d. Tree

4.2.1 Topsoil

Topsoil shall consist of friable surface soil, sandy clay loam, obtained from well-drained areas, free from objects larger than 1½ inches maximum dimension, and

free of subsoil, roots, grass, other foreign matter, hazardous or toxic substances, and deleterious material that may be harmful to plant growth or may hinder grading, planting, or maintenance.

Composition shall be in general accordance with ASTM D5268:

1. Gravel-Sized Fraction: Maximum 5 percent by weight retained on a No. 10 sieve.
2. Sand-Sized Fraction: Minimum 20 to 60 percent passing No. 10 sieve.
3. Silt and Clay-Sized Fraction: Minimum 35 to 70 percent.
4. Organic Matter: Minimum 1.5 percent by dry weight as determined in accordance with ASTM D2974.
5. pH: Range 5.5 to 7.0.

Test topsoil at Virginia Tech Soil Testing Lab and follow amendment recommendations for landscape plants.

4.2.2 Seed Mixes, Rates, and Installation Processes

Seed Materials and Topsoil:

1. Seed Mixes:
 - a. Spring and fall seasons (March 1-May 15 and August 15-November 1): New crop, blue tag certified. Mix to consist of: 15% Kentucky Bluegrass (mix of 3 varieties) and 85% Turf Type Tall Fescue (mix of 3 varieties). Percentages determined by weight.
 - b. Summer seeding (May 15-August 15): New crop, blue tag certified. Mix to consist of: 15% Kentucky Bluegrass (mix of 3 varieties), 80% Turf Type Tall Fescue (mix of 3 varieties), and 5% German Millet. Percentages determined by weight.
 - c. Winter seeding (November 1-March 1): New crop, blue tag certified. Mix to consist of: 15% Kentucky Bluegrass (mix of 3 varieties), 80% Turf Type Tall Fescue (mix of 3 varieties), and 5% Annual Rye. Percentages determined by weight.
2. Hydroseeding fertilizer: 20-20-20 soluble.
3. Straw: Clean oat or wheat straw well-seasoned before bailing, free from mature seed-bearing stalks or prohibited or noxious weeds.
4. Test topsoil at Virginia Tech Soil Testing Lab and follow recommendations for landscape plants.

Seeding Process:

1. Grade seed bed to a smooth, free-draining, even surface with a loose, fine, texture.

2. Remove stones over 1" in any dimension, sticks, roots, rubbish, and extraneous matter from graded seed bed.
3. Seed immediately after preparation of bed.
4. Seed areas within contract limits and any areas outside contract limits disturbed as a result of construction operations.
5. Apply seed with a rotary or drop type distributor. Install seed evenly by sowing equal quantities in two directions, at right angles to each other. Apply seed at 8 lb./1000 sq. ft. or 340 lb./acre.
6. Incorporate seed into top ½" of soil and roll.
7. Place straw or fiber mulch on seeded areas within 24 hours after seeding in a continuous blanket (Contractor will be asked to remove any straw clumps left on the seeded area) at the rate of 2½ tons per acre, or 2 bales per 1,000 square feet of area. A mechanical blower may be used for straw mulch application when acceptable to OUP and VT Grounds. Coordinate with OUP and VT Grounds through the VT PM.
8. Tack straw down by applying light coating of hydromulch.
9. No construction traffic will be permitted on seeded areas. Any seeded area disturbed by Contractor must be re-tilled to 4" depth and re-seeded.

4.2.3 Sod

1. Sod shall be a locally grown blend of fescue and bluegrass (85% fescue/15% bluegrass).
2. Apply sod to topsoil surfaces prepared in equal manner to seeded areas.
3. Install sod within similar timeframe as seeding.
4. Water sod sufficiently to maintain moist root zone soil until establishment.
5. Sod installation may be extended in to summer months with understanding that Contractor will be required to adequately water until establishment.

4.2.4 Topsoil Preparation

1. Subsoil must be mechanically loosened prior to a minimum depth of 8" prior to topsoil spreading.
2. Spread topsoil to 4" minimum depth after subsoil preparation.
3. Compact topsoil to 80% Standard Proctor.

4.2.5 Staging Area Restoration

Staging areas to receive landscaping in any form (lawn, trees, shrubs, etc.) must be restored using the specifications provided in the Soil Profile Rebuilding document located on the VT Soil Profile Rebuilding website.

4.2.6 Lawn Restoration

On existing lawns where substantial (greater than 50%) turf remains within the construction fencing, rake, aerate (twice in opposite directions), fertilize and overseed as noted above at 5 pounds per 1000 square feet. Straw is not required on over seeded lawns.

Provide fertilizer, seed and soil amendments as specified for new lawns and as required to provide a satisfactorily reconditioned lawn. Provide topsoil as required to fill low areas and meet new finished grades.

4.3 TREE CARE PLAN

4.3.1 Purpose

The purpose of the Virginia Tech campus tree care plan is to identify the policies, procedures, and practices that are used in establishing, protecting, maintaining, and removing trees on the Virginia Tech campus. The overall goal of the plan is to ensure a safe, attractive, and sustainable campus urban forest. The University Arborist is currently reviewing the plan and will coordinate with the Arboretum Committee to finalize the plan and submit for University adoption. The specific objectives of the plan are:

1. Ensure proper species selection, high-quality nursery stock acquisition, and industry-consensus planting procedures.
2. Promote appropriate species diversity, tree age distribution, and urban canopy structure for campus urban forest sustainability.
3. Protect high-value campus trees during construction and renovation projects.
4. Promote tree health, structure, and safety by implementing ISA's best management practices when maintaining campus trees.
5. Ensure that trees are reasonably replaced when there is mortality due to weather, pest infestations, injury, or construction displacement.
6. Encourage campus community members to respect and value the campus urban forest.

4.3.2 Responsible Department

Virginia Tech Grounds Department located within the Facilities Department under the direction of the AVP & CFO.

4.3.3 Arboretum Committee

The committee is comprised of faculty and staff from numerous plant-related programs throughout the University. The committee meets biannually, and provides important input into care and improvement of the campus landscape.

4.3.4 Campus Arboriculture Practices

4.3.4.1 Pruning Schedule

The maintenance pruning schedule shall be dictated by tree species, age, function, and placement.

1. Trees less than seven years old should receive structural pruning on an annual or biennial basis.
2. Trees 7-20 years old should receive structural pruning every 2-5 years.
3. Trees 20 years old and older receive maintenance pruning every 5-7 years to clean dead, diseased, dying, and defective branches from the crown.
4. Trees adjacent to roadways, walkways, signs, and street lights are annually inspected for safety and clearance issues and maintenance pruned as necessary.

4.3.4.2 Pruning Practices

To encourage the development of a strong, healthy tree, the following guidelines shall be followed when pruning.

4.3.4.2.1 General

1. Pruning shall not be conducted without a clear objective or outcome.
2. Prune first for safety, next for health, and finally for aesthetics.
3. When removing branches, the pruning cut shall not damage the branch bark ridge and branch collar.
4. Internode (heading) cuts should not be used except in storm response and crown restoration procedures.
5. Branch reduction or thinning should be used to achieve pruning objectives rather than making large (greater than 8 inches in diameter) branch removal cuts.

4.3.4.2.2 Dead Wood Pruning

Pruning shall be performed to remove dead, diseased, dying, and compromised branches; this practice reduces risk, promotes health, and improves appearance.

Large branches should be removed with the aid of ropes and rigging equipment to minimize the risk of tree injury from falling debris.

4.3.4.2.3 Thinning

1. Thinning shall be performed to reduce the density of branches, which increases light penetration, improves visibility, and decreases wind load.
2. Assess how a tree will be pruned from the top down.
3. Favor branches with strong, U-shaped angles of attachment. Remove branches with weak, V-shaped angles of attachment and/or included bark.
4. Ideally, lateral branches should be evenly spaced on the main stem of young trees.
5. Remove any branches that rub or cross another branch.
6. Make sure that lateral branches are no more than one-half to three-quarters of the diameter of the main stem to discourage the development of co-dominant stems.
7. Do not remove more than one-quarter of the living crown of a tree at one time. If it is necessary to remove more, do it over successive years.

4.3.4.2.4 Raising

1. Raising shall be performed to provide vertical clearance from thoroughfares, signs, street lights, and structures
2. Always maintain live branches on at least two-thirds of a tree's total height. Removing too many lower branches will hinder the development of a strong main stem.
3. Remove basal sprouts and vigorous epicormic sprouts.

4.3.4.2.5 Reduction

1. Reduction shall be performed to decrease the overall height of a tree or to decrease the length of an individual branch
2. Use reduction pruning only when absolutely necessary. Make the pruning cut at a lateral branch that is at least one-third the diameter of the stem to be removed.
3. If it is necessary to remove more than half of the foliage from a branch, remove the entire branch.

4.3.4.3 Cultural Practices

4.3.4.3.1 Mulching and Irrigation

Tree mulching – Apply mulch to a depth no greater than 3 inches; care shall be taken to prevent mulching around the root collar. Mulch shall be applied every two years for trees up to approximately 6 inches.

Periodically, drip lines of larger trees, tree groupings, and high value trees are mulched extensively with coarse wood chips.

4.3.4.3.2 Fertilization and Pest Management

Trees are treated for pest problems as needed. There is an extensive Dutch Elm Disease treatment program on campus. There is some regular treatment of Hemlocks on campus for Hemlock Wooly Adelgid and Ash trees for the Emerald Ash Borer.

There is no regular tree fertilization beyond treatment received as a result of fall lawn fertilization. Specimen or high-value trees may receive prescription fertilization when severe nutrient deficiencies are diagnosed.

4.3.4.4 Other Practices

4.3.4.4.1 Tree Removals

Live trees are generally removed only when required to protect the public safety or are detracting from the quality of the landscape.

Trees may be removed after assessment by the University Arborist who will consult with the Arboretum Committee where the committee reaches a consensus.

When the University Arborist and the Arboretum Committee cannot reach a consensus, an independent assessment by a consulting arborist may be required and submitted to the committee for review.

4.3.4.4.2 Planting and Tree Diversity

As the campus is used as a teaching lab and a resilient urban canopy is a priority, increasing the diversity of tree species is extremely important. However, species selection must be dictated by site conditions and available planting stock.

A 'species list' for campus planting is currently under development by the University Arborist and University Landscape Architect. The Arboretum Committee members are consulted regularly to recommend species for

specific site conditions. Committee members often request use of new cultivars and species that are absent or underrepresented on campus to assist in their teaching activities. Based on the vernacular of the site, some landscapes will be planted in native species while others may include selected specimens. Known invasive woody plants are consciously avoided in tree planting plans.

4.3.4.4.3 Storm Response and Recovery

Storm response and recovery are generally accomplished in-house. In a crisis, the first priority is to remove tree debris that blocks campus thoroughfares, disrupts campus operations, or poses a high or imminent risk to the campus community. Once these critical needs are addressed, a prioritized recovery plan is implemented during which seriously damaged trees are systematically removed and other impacted trees are pruned to restore their health and structure while reducing risk. As the tree planting budget permits, lost trees are strategically replaced to restore the structure and function of the campus urban forest in a reasonable time frame. During storm response and recovery, needs for trees requiring specialized equipment or skills not available in-house are addressed by an outside contractor.

4.3.5 Goals and Targets

4.3.5.1 Tree Inventory

A digital tree inventory covering the core campus has been completed. Updates and inventory maintenance will be performed by the University Arborist or designated staff/faculty. The inventory may be used for campus planning purposes, tree management, academic exercises (read only access), and the general public (read only access). Notify the University Arborist for needed updates or questions.

4.3.5.2 Tree Canopy and Campus Master Plan

Increasing the campus tree canopy is an important component of the draft University Sustainability Plan and VT CAC. The following information on the campus forest areas and campus tree and shrub list were excerpted from the 2010 Campus Design Principles Manual by Sasaki Associates.

4.3.5.2.1 Campus Forest Areas

The proposed campus forest areas consist of existing wooded areas and open areas proposed for reforestation. There are four long-term objectives for the forest areas.

1. The first is to maintain stands of large native trees with associated understory and ground layer plants that will provide a regionally fitting visual theme for beautifying and unifying the University owned areas surrounding the core campus.
2. The second is to provide the environmental benefits of cooling, enhanced storm water management, erosion control and water quality protection, increased species diversity and reduced water consumption and energy expenditure for grounds maintenance.
3. The third is to provide areas for research, education, and passive recreation in close proximity to the campus.
4. The fourth is to provide an example of environmental responsibility that will serve to heighten public awareness of the relationship between human society and the natural environment.

All of these objectives are supportive of the VT CAC and University Sustainability Plan. The University is investigating the establishment of forest easements as a means of gaining stormwater management credits.

In balancing these objectives, it should be recognized that in areas of high visual sensitivity along roadways, the aesthetic quality of the forest should be given priority. Research activities that may result in “unattractive” landscapes or the dominance of invasive exotic species over extended periods of time should be located in areas with limited public exposure.

The forest areas along roadways should be designed and managed to enhance and unify the campus image over the long-term with a minimum of short-term unattractiveness during periods of canopy establishment. The detailed planning of reforestation initiatives should also include, as an overarching design parameter, the maintenance of campus safety and security, and the preservation of significant views.

The forest areas should not be designed as strict restorations of the forest communities that naturally occur or occurred in the region during previous times. Rather, the forest areas should be designed to simulate the general structure and ecosystem functions of naturally occurring

forest communities of the region, with a composition of species that may not necessarily replicate the original forests of the area.

The designs and the management methods for each forest area should respond to the existing vegetation soils, hydrology, exposure, size, shape and context of each site.

The methods for establishing new forests should be adapted to the site conditions and budget available for each site.

The preferred method of forest establishment in areas of high public visibility is to plant canopy trees at densities and proportions of species similar to their final desired configuration, and to allow and encourage invasion by understory species as the forest canopy develops.

Examples of the canopy trees that would be included in the initial canopy plantings are listed in the following table.

The list will require refinement based on more detailed studies that would address issues of plant availability in required sizes, species transplant characteristics, and the matching of tree types to field conditions.

<i>Acer saccharum</i> – Sugar Maple	<i>Pinus strobus</i> – White Pine
<i>Acer rubrum</i> – Red Maple	<i>Pinus echinata</i> – Short-leaf Pine
<i>Betula lenta</i> – Sweet Birch	<i>Quercus alba</i> – White Oak
<i>Carya sp</i> – Hickory	<i>Q. coccinea</i> – Scarlet Oak
<i>Fagus grandifolia</i> – American Beech	<i>Q. lyrata</i> – Overcup Oak
<i>Juniperus virginiana</i> – Eastern Red Cedar	<i>Q. macrocarpa</i> – Burr Oak
<i>Liquidambar styraciflua</i> – Sweet Gum	<i>Q. prinus</i> – Chestnut Oak
<i>Liriodendron tulipifera</i> – Tuliptree	<i>Q. borealis</i> – Northern Red Oak
<i>Nyssa sylvatica</i> – Black Tupelo	<i>Q. shumardii</i> – Shumard Oak
<i>Prunus serotina</i> – Black Cherry	<i>Q. velutina</i> – Black Oak
<i>Pinus rigida</i> – Pitch Pine	<i>Tilia americana</i> – Basswood

In the interest of minimizing the period for canopy establishment and increasing their immediate visual effect, trees should be planted at the largest sizes practical. Weed and grass competition should be reduced in the immediate area around the planted trees until such time that the new planting can successfully compete.

Existing grass and forbes should be allowed to grow without mowing in the remainder of the project area, until they are ultimately shaded out and colonized by woody plants. The grass should be removed if rodent control becomes necessary to protect young trees from girdling.

To maintain a neat edge along roadways, a narrow strip of lawn, free of trees, may be maintained during the establishment years, and later be phased out or maintained as a grass shoulder.

Other methods of planting may be employed in situations where less immediate visual effects are acceptable, or where soil conditions, exposure or the project budget will not allow planting large canopy trees at ultimate densities. These methods include:

1. Planting desired canopy trees at lower densities in loose savanna configurations that will, over time, naturally close or can be supplemented with future planting.
2. Planting desired canopy trees at higher than ultimate densities (probably with smaller size planting stock for cost reasons) to increase the rate of canopy establishment and the opportunity for development of an understory layer.
3. Planting fast-growing pioneer tree and shrub species at medium to high densities to rapidly establish a canopy followed by inter-planting with longer lived shade tolerate canopy species.

Variations of these methods are also feasible.

The planting of fast growing temporary shelter belts and hedgerows may also be desirable to provide protection for the new forests during the first several decades of their establishment. In proposed forest areas along the edges of large parking areas it would be desirable to include a large proportion of conifers for visual and wind screening. For example, the Prices Fork Road edge between West Campus Drive and Stanger Street should be planted in this way to supplement the street trees that are already there.

4.3.5.2.2 Campus Tree and Shrub List

Refer to the OUP website for the Campus Tree and Shrub list. This list provides the preferred woody plants for use on the Virginia Tech campus. This is not an exhaustive list of all acceptable plants. Other plants that follow the design standards may be used.

4.3.6 Tree Damage Assessment, Enforcement, and Penalties

Assessment on low profile trees is performed by the University Arborist. High profile trees are assessed by the University Arborist with support from the Arboretum Committee or an outside consultant. Enforcement of protection measures is performed by project managers and on-site engineers.

4.4 SIGNAGE

1. Interior and exterior signage shall meet University signage standards established by the OUP in order to provide visual identity and conformity as well as to meet accessibility and safety code requirements. Reference the materials below, but note that additional discussion must occur on a project-level basis regarding incorporation of a University mark. The exterior signage standards show a mark the use of which has been discontinued. When a mark is needed, signage shall feature the new University mark. OUP shall be consulted on the presence of a University mark on signage packages.
 - a. Appendix E: Interior Signage Standards Manual
 - b. Appendix F: Campus Wayfinding Guidelines
2. The A/E shall utilize Virginia Tech standard permanent room numbering on the floor plans during the preliminary design review phase.
3. The A/E shall provide a signage package for review and approval by the OUP, including specifications, installation plans and graphic layouts for directional signage and evacuation maps utilizing Virginia Tech's templates.
4. Signage components are required to match existing signage systems.
 - a. The product components specified in Appendix E: Interior Signage Standards Manual and Appendix F: Campus Wayfinding Guidelines shall be used to the exclusion of all others.
 - b. Approved manufacturer is Appco. (Current University approved contract for University signage.)
5. Signage manufacturing and installation shall exhibit quality workmanship.
6. Signage, including donor recognition and electronic signage, shall be identified by the A/E on floor plans and elevations as required for coordinating lighting, power and finishes. All donor recognitions must be approved by OUP.

4.5 EXTERIOR IMPROVEMENTS

4.5.1 Exterior Site Furnishings

OUP shall be consulted on all exterior metal fixtures and furnishings. All fixtures and furnishings shall be finished with a dark bronze powder coat to match campus standards unless an alternate color and/or finish is approved by the OUP.

Approved powder coat manufacturers and colors include:

1. Tiger Drylac Roman Bronze Matte (39/60060)

2. Sherwin-Williams custom color formula

BAC COLORANT	OZ	32	64	128
B1 - Black	4	57	-	-
Y3 - Deep Gold	2	2	-	-
R2 - Maroon	-	27	-	-
W1 - White	-	36	-	-

3. Benjamin Moore custom color formula

HP29 - 4X		
Y3	2x	14.5000
S1	5x	13.7500
W1	2x	22.0000
R3	1x	2.1250

Refer to Appendix D: Site Furnishing Guide. OUP must review furniture/equipment plans and requests to use specialty or higher-end furniture.

4.5.1.1 Handrails

1. For posts set in concrete, furnish matching sleeve or inserts not less than 5 inches long. Aluminum handrails are acceptable; steel handrails must be powder coated. Provide positive drainage where handrails are set into sidewalks.
2. When using stainless steel railing system all mechanical fasteners used in the assembly of the railing system shall be manufactured from stainless steel.

4.5.1.2 Storage

Prefabricated storage sheds shall not be placed on campus, nor shall shipping containers be placed for use as storage facilities. Existing storage sheds may remain but shall not be improved (except for ordinary maintenance and repair). These structures shall be removed at the end of their useful life. Any existing shipping containers shall be removed as soon as feasibly possible.

4.5.1.3 Site Seating

Stadium Seating – The University does not generally endorse stadium seating in the campus landscape. Such seating arrangements, as traditionally composed, do not meet the University's standards for universal access. However, accessible variations are possible and should be discussed with the OUP early in the site design process.

4.5.2 Paving and Curbs

Accessibility related improvements (ramps, curb cuts, walks, crossings, etc.) must follow ADA Standards related to Title II facilities.

In general, pavement repair shall follow accessibility requirements and the standard shown in the pavement repair detail in Transportation Details located in the VT Design Standard Detail Library and in VDOT standards.

4.5.2.1 Concrete Paving/Walks

1. In general, sidewalks shall follow accessibility requirements and the standard concrete slab detail in Transportation Details located in the VT Design Standard Detail Library.
2. Sidewalks designed for significant vehicle traffic shall be designed with a curb including sidewalk corners. Lawn adjacent to the curb should be graded to match the top of the curb.
3. Any concrete walk over 6 feet in width should be specified with fiber reinforcement.
 - a. Three pounds of Helix 5-25 fiber (or equal) per yard.
4. Use of exposed aggregate and colored concrete is encouraged to reduce glare and add interest to concrete surfaces.
5. Plans must show expansion and control joint patterns with maximum control joint spacing equaling the width of the walk.
6. All adjacent pours, and new to old work tie-ins must be doweled at minimum 3 feet on center.
7. Concrete surfaces shall receive medium weight broom finish.
8. Control joints shall be saw cut to one-quarter concrete thickness, followed with a 'V' chaser blade to chamfer joint. Saw cut within 24 hours of finishing.
9. Minimum walk radius is 6 feet; for vehicle use, a 15-foot radius is preferred.
10. All welded wire fabric shall be manufactured and installed in flat sheets. Rolled welded wire fabric is not permitted.
11. Standard Concrete walk- Thickness of 6 inches with standard reinforcing mesh.
12. Walks intended for service or emergency access shall be 8 inches thick with heavy gauge welded wire mesh and fiber reinforcement.
 - a. Five pounds of Helix 5-25 fiber (or equal) per yard.
13. Walks with a designated daily service function (e.g., trash truck access) shall have a curb edge (concrete or other approved material).

14. All exterior slabs-on-grade and concrete slabs shall have a minimum thickness of 5½ inches.
15. All traffic-rated areas shall have a minimum thickness of 7½ inches.
16. A sealer is required for all exterior flatwork.
17. Exterior concrete shall not be painted or stained.

4.5.2.2 Asphalt Walks

1. Standard asphalt is intended for non-vehicular use only such as bike paths.
2. Heavy asphalt is intended for vehicular use such as parking lots and access drives.
3. Thickness of aggregate base, asphalt sub-base and wearing surface are based on expected vehicle loads.
4. Service access paths shall have a curb edge (concrete or other approved material).

4.5.2.3 Curbing

1. Site curbing to match VDOT CG-2 or CG-6 as applicable.
2. Other materials are acceptable such as granite, or precast concrete in limited use where warranted by design intent.

4.5.3 Bollards

The basis of design shall be the MaxiForce Collapsible Bollard model #MCSP-SS1-U or approved equal. The finish shall be powder coated steel and where possible the color shall match the campus standard dark bronze. See DCSM section 4.5.1 for approved manufacturers and color formulas.

4.5.4 Exterior Stairs

1. See the VT Design Standard Detail Library for the handrail detail for exterior steps.
2. All handrail and guardrail powder coats shall match the campus standard dark bronze. See DCSM section 4.5.1 for approved manufacturers and color formulas.
3. All exterior steps shall be a minimum of two risers. Single riser steps are not permitted.
4. All exterior steps shall be designed to follow the formula: Tread Depth + (2 × Riser Height) = 26 or 27 inches.
5. Riser height must be between 6 to 7 inches.
6. Cheek walls are preferred for exterior steps.

7. Metal stair nosings are not acceptable.
8. The leading edge (intersection of the tread and riser) of stairways shall be perpendicular to the direction of travel. Stairways with the direction of travel at an angle to the leading edge of the stairway are not acceptable.

4.5.5 Unit Paving

1. Precast Concrete Unit Paving – paver standard basis of design is Techo-Bloc Blu, 60 mm (pedestrian) or 80 mm (vehicular), with the acceptable colors of Champlain Grey, Shale Grey, and 5% Onyx Black in larger areas.
2. OUP shall also be consulted on the use of porous paving materials.

4.5.6 Retaining Walls

Retaining Walls – standards in-development; OUP shall be consulted on the design of:

1. Precast or Cast-In-Place Concrete Retaining Walls
2. Hokie Stone Retaining Walls
3. Gabion Walls (cannot be used in Campus Core)

4.5.7 Fences and Gates

1. Decorative Metal Fence and Gates: include decorative metal guardrail detail shown in VT Design Standard Detail Library.
2. Wood Fence and Gates: Generally not acceptable in campus core; when needed use VDOT 4-Board fence detail.
3. Green Screen: Generally not accepted in high-visibility areas of campus core, but where appropriate, fences shall be constructed of 2" × 6" 6-gauge mesh with 2" or 2.5" 16-gauge square posts spaced 96.5" on-center (max) and finished with a dark bronze colored powder coat to match campus standards. See DCSM section 4.5.1 for approved manufacturers and color formulas. Fence height can range from 4 to 8 feet tall. Green screens must be planted.

4.5.8 Building Edge

Tan river stone size #3/4 on woven landscape fabric shall be used.

Separate from lawn and landscape areas with heavy gauge metal edging.

4.5.9 Irrigation

Campus landscapes generally are not irrigated by automatic irrigation system. Inclusion of an automatic irrigation system requires discussion with VT Facilities Building and Grounds.

Freeze resistant wall hydrants should be placed on buildings on each façade at approximately 100-foot spacing and shown on the planting plan.

For landscapes where water access is required in the landscape, freeze resistant boxed ground hydrants may be used.

4.5.10 Exterior Screening

The OUP shall be consulted on all screening requirements on buildings and in the campus landscape. Elements requiring screening include, but are not limited to, all mechanical/electrical/plumbing infrastructure and network infrastructure visible from the exterior of a building. These elements should be installed in a discreet location on the structure.

4.6 STORMWATER DESIGN REQUIREMENTS

4.6.1 References

Except where more stringent requirements are presented in the DCSM, stormwater management control shall comply with stated requirements. Applicable design references are provided.

1. Stormwater Hydrology shall comply with state requirements. The primary design references are:
 - a. VDOT Drainage Manual
 - b. Virginia Stormwater Management Handbook (VSWMH)
 - c. Virginia Stormwater Best Management Practice (BMP) Clearinghouse
2. Open Channels shall comply with VDOT and DEQ requirements. The primary design references are the latest editions of the following:
 - a. VDOT Drainage Manual
 - b. VDOT Road and Bridge Standards
 - c. Virginia Erosion and Sediment Control Handbook (VESCH)
 - d. Hydraulic Engineering Circular Number 15 (HEC-15), Design of Roadside Channels with Flexible Linings
3. Culverts shall comply with VDOT requirements. The primary design reference is the VDOT Drainage Manual. Other appropriate references include the latest editions of the following:
 - a. VDOT Road and Bridge Standards
 - b. VDOT Road and Bridge Specifications
 - c. VESCH
 - d. VDOT Instructional and Informational Memorandum IIM-LD-121.15, Allowable Pipe Criteria for Culverts and Storm Sewers

- e. Federal Highway Administration (FHWA) Hydraulic Design of Highway Culverts HDS No. 5, Pub. No. FHWA- HIF-12-026
 - f. FHWA Debris Control Structures Evaluation and Countermeasures HEC No. 9, Pub. No. FHWA-IF-04-016
 - g. FHWA Culvert Design for Aquatic Organism Passage HEC No. 2, Pub. No. FHWA-HIF-11-008
4. Storm drainage systems shall comply with VDOT and DEQ requirements. The primary design reference is the VDOT Drainage Manual. Other appropriate references include:
 - a. VDOT Road and Bridge Standards
 - b. VDOT Road and Bridge Specifications
 - c. VESCH
 5. Design and construction of stormwater detention facilities shall comply with VDOT and DEQ requirements. The primary design references are:
 - a. VSWMH
 - b. VDOT Drainage Manual
 - c. VESCH
 - d. VDOT Standards
 - e. Virginia Stormwater BMP Clearinghouse
 6. Energy dissipators shall comply with VDOT and other state requirements. The primary design references are the VDOT Drainage Manual and the VESCH. Other appropriate references include:
 - a. VDOT Road and Bridge Standards
 - b. VDOT Road and Bridge Specifications
 - c. VSWMH
 - d. FHWA Design of Riprap Revetment HEC No. 11 (Pub. No. FHWA-IP-89-016 1989/2000)
 - e. FHWA Hydraulic Design of Energy Dissipators for Culverts and Channels HEC No. 14 (Pub. No. FHWA-EPD-86-110 Sept. 1983 and FHWA-IF-00-02 2000)
 - f. U.S. Dept. of the Interior – Bureau of Reclamation: Hydraulic Design of Stilling Basins and Energy Dissipators (Engineering Monograph No. 25)
 - g. U.S. Dept. of the Interior – Bureau of Reclamation: Design of Small Canal Structures
 7. Stormwater quality best management practices shall comply with DEQ requirements. The primary design reference is the Virginia Stormwater BMP Clearinghouse.

4.6.2 Stormwater Hydrology

Stormwater hydrology defines the means and methods to calculate stormwater runoff from a designated area. This section documents the hydrologic practices used to establish design flows necessary to prepare the required stormwater peak flow and storage calculations.

4.6.2.1 Storm Drainage System Design Frequencies

Design frequencies shall be selected consistent with good engineering practice and regulatory requirements. The design frequency requirements in this section are minimum standards. Specific conditions may dictate that less frequent design frequencies should be used.

Storm drainage systems consist of open channels, culverts, and storm drains. Designs shall be based on the following minimum design storm frequencies:

Type of System	Frequency
Open Channels: Channel Capacity	10-year
Open Channels: Protective Living	2-year
Culverts	10-year
Storm Drains	10-year

Additionally, all storm drainage designs for open channels, culverts, and storm drains shall be checked for the 100-year flow condition where there is the possibility of downstream flooding, overtopping primary roads, experiencing significant economic loss, or catastrophic failure. Where justified by the consequences of failure, the minimum design recurrence interval shall be increased.

4.6.2.2 Stormwater Management Facilities

Certain stormwater management facilities temporarily store a portion of stormwater runoff to mitigate increases in stormwater runoff peak flows and volumes due to the effects of land development.

4.6.2.3 New Development

Channel protection and flood protection shall be addressed in accordance with the criteria set forth in the Virginia Stormwater Management Program (VSMP) Regulations.

4.6.2.4 Time of Concentration (T_c) and Travel Time (T_t)

4.6.2.4.1 General

Travel Time (T_t) is the time it takes runoff to travel from one location to another in a watershed. Travel Time is a component of Time of Concentration (T_c), which is the time for runoff to travel from the most hydraulically distant point in the watershed to the outfall. The Time of Concentration is computed by summing all the travel times for consecutive components of the drainage conveyance system. Travel Time and Time of Concentration generally consist of three flow types – overland flow, shallow concentrated flow, and open channel flow. The following methods shall be used to determine the flow and velocity for the various conditions; however, the results shall be reviewed for reasonableness, and the results shall be revised if needed to provide a reasonable velocity and flow time that will best represent the study area.

When designing a drainage system, the Time of Concentration is not necessarily the same before and after land disturbing activities have been completed. Therefore, the travel time path shall be reflective of the actual conditions both before and after the land disturbing activities. If T_c is less than 6 minutes, then a value of 6 minutes will be used for all calculations. Whereas, if T_c is greater than or equal to 6 minutes, then the calculated value will be used.

In some cases, runoff from a portion of the drainage area that is highly impervious may result in a greater peak discharge than would occur if the entire drainage area were considered. In this case, adjustments shall be made to the drainage area by disregarding those areas where the travel time is too long to add substantially to the peak discharge.

To prevent small drainage areas from skewing the time of concentration calculation results, when establishing subdrainage areas for analysis, the largest subdrainage area shall be no greater than 5 times the area of the smallest subdrainage area.

4.6.2.4.2 Overland (Sheet) Flow

Overland flow is flow that occurs at the upper end of a watershed, where flow is not concentrated and there are no channels. The length of overland flow shall be reflective of actual conditions and shall normally be no greater than 100 feet.

4.6.2.4.3 Shallow Concentrated Flow

Shallow concentrated flow is the flow that occurs when minor rivulets form just downstream from the overland flow. The maximum allowable length for shallow concentrated flow shall be 1000 feet.

4.6.2.4.4 Open Channel Flow

Open channel flow occurs where stormwater flow converges in gullies, ditches, and natural or man-made conveyances.

4.6.2.4.5 Pipe Flow

Pipe flow is the flow that occurs through culverts and storm drains. Use full-flow pipe velocities, unless it can be shown that the pipe will operate at partially full conditions. If it can be shown that the pipe will operate at a partially full condition, then the partially full pipe velocity may be used.

Design of culverts is presented in DCSM section 4.6.4. Design of storm drain systems is presented in DCSM section 4.6.5.

4.6.2.5 Hydrologic Methods

4.6.2.5.1 General

There are a variety of widely used hydrologic methodologies. Each has its strengths and weaknesses. In the interest of standardizing hydrologic calculations, the following methodologies will be used for all projects, unless a variance is granted. A variance will only be granted if it may be demonstrated that good engineering practice dictates the use of another method.

4.6.2.5.2 Peak Discharge Methods for Design of Storm Drainage Systems

The Rational Method may be used to design storm drainage systems for drainage areas up to 200 acres.

The Soil Conservation Service (SCS) Method may be used for drainage areas up to 10 square miles.

For drainage areas greater than 10 square miles, calculations shall be performed using at least two separate methods as described in the VDOT Drainage Manual (SCS Method, regression equations, and/or stream gage data). The design peak flow shall be selected based on a professional evaluation of the results of the various methods.

4.6.2.5.3 Hydrograph Methods for Design of Stormwater Management Facilities

The SCS method must be used to design stormwater management facilities.

4.6.2.6 Methodologies

Following is an abbreviated discussion of each method. Refer to the VDOT Drainage Manual for a more complete discussion of the Rational Method and the VSWMH for a more complete discussion of the SCS Method.

4.6.2.6.1 Rational Method

4.6.2.6.1.1 General

The Rational Method is expressed as:

$$Q = C_f \times C \times I \times A$$

Where:

Q = Peak flow rate of runoff, cubic feet per second (cfs)

C_f = Saturation factor

C = Runoff coefficient representing a ratio of runoff to rainfall (dimensionless) (See VESCH Table 5-2 below.)

I = Average rainfall intensity for a duration equal to the time of concentration for a selected return period (in/h)

A = Drainage area contributing to the design location, acres (ac)

**TABLE 5-2
VALUES OF RUNOFF COEFFICIENT (C) FOR RATIONAL FORMULA**

Land Use	C	Land Use	C
Business: Downtown areas Neighborhood areas	0.70-0.95 0.50-0.70	Lawns: Sandy soil, flat, 2% Sandy soil, average, 2-7% Sandy soil, steep, 7% Heavy soil, flat, 2% Heavy soil, average, 2-7% Heavy soil, steep, 7%	0.05-0.10 0.10-0.15 0.15-0.20 0.13-0.17 0.18-0.22 0.25-0.35
Residential: Single-family areas Multi units, detached Multi units, attached Suburban	0.30-0.50 0.40-0.60 0.60-0.75 0.25-0.40	Agricultural land: Bare packed soil • Smooth • Rough Cultivated rows • Heavy soil, no crop • Heavy soil, with crop • Sandy soil, no crop • Sandy soil, with crop Pasture • Heavy soil • Sandy soil Woodlands	0.30-0.60 0.20-0.50 0.30-0.60 0.20-0.50 0.20-0.40 0.10-0.25 0.15-0.45 0.05-0.25 0.05-0.25
Industrial: Light areas Heavy areas	0.50-0.80 0.60-0.90	Streets: Asphaltic Concrete Brick	0.70-0.95 0.80-0.95 0.70-0.85
Parks, cemeteries	0.10-0.25	Unimproved areas	0.10-0.30
Playgrounds	0.20-0.35	Drives and walks	0.75-0.85
Railroad yard areas	0.20-0.40	Roofs	0.75-0.95
<p>Note: The designer must use judgement to select the appropriate "C" value within the range. Generally, larger areas with permeable soils, flat slopes and dense vegetation should have the lowest C values. Smaller areas with dense soils, moderate to steep slopes, and sparse vegetation should be assigned the highest C values.</p>			

4.6.2.6.1.2 Saturation Factor

The saturation factor (C_f) is an adjustment factor for modifying the runoff coefficient (C) for storms that are less frequent than a 10-year recurrence interval. The product of C_f and C should not be greater than 1.0. Where the product of C_f and C is greater than 1.0, use 1.0.

Recurrence Interval (Years)	C_f
2, 5, and 10	1.0
25	1.1
50	1.2
100	1.25

4.6.2.6.1.3 Runoff Coefficient

The runoff coefficient (C) is a variable of the Rational Method that requires significant judgment and understanding for proper selection.

As the slope of the drainage basin increases, the selected C-value (from VESCH Table 5-2) should also increase as follows:

1. The lower range of C-values should be used where the majority of the slopes are less than 2 percent.
2. The average range of C-values should be used where the majority of slopes are from 2 to 5 percent.
3. The higher range of C-values should be used where the majority of the slopes are greater than 5 percent.

The C-value selection should be based on the soil type as follows:

1. The lower range C-values should be used in sandy and other more pervious soils
2. The higher range of C-values should be used in clayey and other less pervious soils.

It is often necessary to develop composite C-values based on the different land uses and other factors in a drainage basin. The composite C-value must be representative of the drainage basin. Averaging the C-values for mixed pervious/impervious watersheds may underestimate the peak flow rate.

4.6.2.6.1.4 Average Rainfall Intensity

Rainfall intensity (I) shall be determined by utilizing the National Oceanic and Atmospheric Administration (NOAA) Atlas 14.

4.6.2.6.1.5 Drainage Area

Drainage area (A) is measured in acres and is determined from evaluating a topographic map of the area.

4.6.2.6.2 SCS Method

4.6.2.6.2.1 General

The SCS Method may be used for computing peak flow rates and generating hydrographs for storms of selected return frequencies. This approach takes into account the time distribution of the rainfall, the initial rainfall losses to interception and depression storage, and an infiltration rate that decreases during the course of a storm.

4.6.2.6.2.2 24-Hour Rainfall and Distribution

The 24-hour rainfall is determined by consulting NOAA Atlas 14.

4.6.2.6.2.3 Curve Number

The SCS method uses a combination of soil conditions and land use (ground cover) to assign a runoff factor to an area. These runoff factors, or runoff curve numbers (CN), indicate the runoff potential of an area. The CN requires significant judgment and understanding for proper selection.

When calculating existing rates of runoff (pre-construction), assume that all cover types are in good hydrologic condition.

Hydrologic Soils Groups include types A, B, C, and D, with type A being the most permeable and type D the least permeable. Soil maps for Virginia may be obtained by referring to the <http://soils.usda.gov>.

4.6.2.6.2.4 Drainage Area

Drainage areas for each sub-basin should be identified on an appropriate topographic map. The United States Geological Survey (USGS) quadrangle maps are often appropriate to delineate drainage areas that extend beyond the site development area.

4.6.2.6.2.5 Elevation – Storage Relationship

When runoff hydrographs are being routed through a stormwater management facility, the relationship between the elevation (or depth) of stored water in the facility and storage volume needs to be known and input into the calculation. Often this information is obtained by determining the pond area bounded by contour lines on a grading plan. Enough data pairs (elevation – storage) must be provided to properly model conditions.

4.6.2.6.2.6 Elevation – Discharge Relationship

When runoff hydrographs are being routed through a stormwater management facility, the relationship between the elevation (or depth) of stored water in the facility and the discharge rate from the facility needs to be known and input into the calculation. The development of this relationship requires an understanding of the design conditions and underlying hydraulic principles. The hydraulic principles and equations governing the discharge rate will often change several times at varying elevations, based on the flow control and conveyance structures. These include weir flow, orifice flow,

culvert inlet control, culvert outlet control, open channel flow, and possible effects from downstream tailwater.

4.6.2.7 Pre-Development Site Conditions

Pre-development hydrologic calculations for land disturbing activities shall consider the site conditions that exist at the time that plans for the land development are submitted to SID. Where phased development or plan approval occurs (preliminary grading, demolition, etc.), the existing conditions at the time prior to the first item being submitted shall establish the pre-development conditions.

For the purposes of computing pre-development runoff, all pervious lands on the site shall be assumed to be in good hydrologic condition, regardless of conditions existing at the time of computation.

4.6.2.8 Drainage Area Analysis

When determining the stormwater management requirements for quantity control, an analysis of the pre- and post-development site conditions must be conducted. The drainage area analysis shall reflect the ultimate development conditions of the property where the land disturbing activity is being conducted.

To prevent the undersizing of stormwater management components, upstream property conditions in the entire watershed shall be considered in the drainage area analysis. Improvements to stream channels and conveyance systems shall be analyzed based on the ultimate development conditions. Design of drainage infrastructure shall be based on proposed development and the associated density of impervious areas.

When a site contains or is divided by multiple drainage areas, the downstream receiving channel for each area must be analyzed in accordance with the VSMP regulations.

The downstream limits of analysis and channel adequacy shall be determined in accordance with the VSMP regulations.

4.6.3 Open Channel Design Methodology

Open channels are man-made ditches, channels, as well as natural channels, that are used to convey stormwater runoff. This section defines the criteria and restrictions to be used in designing open channels.

Grass Channels are a type of water quality BMP with design requirements beyond those of the typical open channel. The design specifications for Grass Channels can be found on the Virginia Stormwater BMP Clearinghouse.

4.6.3.1 Open Channels

Open channels are classified as either major channels or minor channels. The base design storm for storm drainage systems are the 2- and 10-year, 24-hour storm events, for velocity and capacity. However, the entire system must be capable of handling a 100-year, 24-hour design storm.

4.6.3.2 Design Flow

Design flow for open channels is contained in DCSM section 4.6.3. Design flows for open channels must be contained within the channel with adequate freeboard from the top of the bank to the peak water surface elevation. See DCSM section 4.6.3.9 for adequate freeboard requirements for capacity calculations.

Capacity calculations shall be made at the flattest section of the channel.

4.6.3.3 Hydrology

See DCSM section 4.6.2 for the methodology used to determine peak flows for a given design frequency.

4.6.3.4 Channel Hydraulics

Open channel design will be based on Manning's Equation for open channel flow:

$$Q = A \times 1.49/n \times R^{2/3} \times S^{1/2}$$

Where:

Q = Flow rate in the open channel (cfs)

A = Cross-sectional area of the flow in the channel (sq. ft.)

R = Hydraulic radius, A/wetted perimeter (ft.)

S = Channel slope (ft./ft.)

n = Channel roughness coefficient (See VDOT Table: Appendix 7D-1 below.)

Appendix 7D-1 Values of Roughness Coefficient n (Uniform Flow)

Type of Channel and Description	Minimum	Normal	Maximum
LINED CHANNELS (Selected linings)			
a. Concrete			
1. Trowel finish	0.011	0.013	0.015
2. Float finish	0.013	0.015	0.016
3. Gunite, good section	0.016	0.019	0.023
b. Asphalt			
1. Smooth	0.013	0.013	-
2. Rough	0.016	0.016	-
c. Riprap (st'd VDOT sizes)			
1. Class 1A	0.033	0.038	-
2. Class 1	0.035	0.040	-
3. Class 2	0.037	0.042	-
4. Class 3	0.039	0.045	-
5. Type I	0.041	0.047	-
6. Type II	0.044	0.050	-
EXCAVATED OR DREDGED			
a. Earth, straight and uniform			
1. Clean, recently completed	0.016	0.018	0.020
2. Clean, after weathering	0.018	0.022	0.025
3. Gravel, uniform section, clean	0.022	0.025	0.030
4. With short grass, few weeds	0.022	0.027	0.033
b. Earth, winding and sluggish			
1. No vegetation	0.023	0.025	0.030
2. Grass, some weeds	0.025	0.030	0.033
3. Dense weeds or aquatic plants in deep channels	0.030	0.035	0.040
4. Earth bottom and rubble sides	0.025	0.030	0.035
5. Stony bottom and weedy sides	0.025	0.035	0.045
6. Cobble bottom and clean sides	0.030	0.040	0.050
c. Dragline excavated or dredged			
1. No vegetation	0.025	0.028	0.033
2. Light brush on banks	0.035	0.050	0.060
d. Rock cuts			
1. Smooth and uniform	0.025	0.035	0.040
2. Jagged and irregular	0.035	0.040	0.050
e. Channels not maintained, weeds and brush uncut			
1. Dense weeds, high as flow depth	0.050	0.080	0.120
2. Clean bottom, brush on sides	0.040	0.050	0.080
3. Same, highest stage of flow	0.045	0.070	0.110
4. Dense brush, high stage	0.080	0.100	0.140
NATURAL STREAMS			
1. Minor streams (top width at flood stage <100 ft)			
a. Streams on Plain			
1. Clean, straight, full stage, no rifts or deep pools	0.025	0.030	0.033
2. Same as above, but more stones/weeds	0.030	0.035	0.040
3. Clean, winding, some pools/shoals	0.033	0.040	0.045
4. Same as above, but some weeds/stones	0.035	0.045	0.050
5. Same as above, lower stages, more ineffective slopes and sections	0.040	0.048	0.055
6. Same as 4, but more stones	0.045	0.050	0.060
7. Sluggish reaches, weedy, deep pools	0.050	0.070	0.080

* Rev 7/09

4.6.3.5 Channel Velocity

The lining of open channels with drainage areas of five acres or less shall be designed to withstand the erosive effects of a 2-year storm. The final design shall be consistent with velocity limitations for the selected channel lining, as presented in the table below.

Open channels associated with dam embankment spillways or other structures where catastrophic failure could result from a lining failure may be required to be designed to withstand a more severe storm event.

Where open channels receive flow from storm drains, culverts, or other open channels, or in other areas where channel velocity may cause scouring or erosion, outlet protection or energy dissipation may be necessary to reduce

the potential for severe erosion. For the design of energy dissipation devices, see DCSM section 4.6.7.

Velocity calculations shall be made at the steepest section the channel. The VDOT Drainage Manual provides the following table for maximum velocity based on channel lining selection.

Maximum Velocity Based on Channel Lining

Channel Lining	Maximum Velocity (Design Storm)	
	Erosion Resistant Soils ¹	Easily Erodible Soils ²
Vegetative-Lined Channels		
Tall Fescue Grass Mixtures	5 fps	3 fps
Kentucky Bluegrass	5 fps	3 fps
Annual and Perennial Rye	4 fps	3 fps
Sod	4 fps	3 fps
Geosynthetic-Lined Channels		
VDOT EC-2	4 fps	
VDOT EC-3, Type A	7 fps	
VDOT EC-3, Type B	10 fps	
Other	Per Mfr Recommendations	
Riprap	Dependent on stone size and thickness, see VDOT Drainage Manual for design of riprap	
Concrete	None	

¹ Erosion resistant soils include those with a high clay content and high plasticity, silty clay, sandy clay, and clay.

² Easily erodible soils include those with a high content of fine sand or silty, lower plasticity or non-plasticity, sand, silt, sandy loam, and silty loam with an erodibility factor (K) greater than 0.35.

4.6.3.6 Channel Slope

Generally the slope of an open channel shall be established by the site topography. Open channels must be graded to drain with no standing water following a rain event. The minimum allowable grade shall be 2 percent for vegetative lined and riprap-lined open channels and 1 percent for a concrete open channel.

The maximum allowable grade for a stormwater channel shall be dependent on the channel lining materials and its ability to withstand erosion during the design storm.

4.6.3.7 Cross Sectional Area

Open channel cross-sectional area shall be designed based on site restrictions and channel capacity required. Acceptable cross-sectional area options include:

1. Vee
 - a. For design aids, see the VDOT Drainage Manual and the VESCH.

- b. The maximum side slope of a vee-shape open channel is 3 horizontal to 1 vertical for natural or vegetated channels and is 2 horizontal to 1 vertical for riprap, concrete or as approved by SID.
- 2. Parabolic
For design aids, see the VDOT Drainage Manual and the VESCH.
- 3. Trapezoidal
 - a. For design aids, see the VDOT Drainage Manual and the VESCH.
 - b. The maximum side slope of a trapezoidal-shape open channel is 3 horizontal to 1 vertical for natural or vegetated channels and is 2 horizontal to 1 vertical for all other linings engineered to be stable at this slope.
- 4. Rectangular
 - a. Rectangular channels shall only be allowed where site restrictions prevent the installation of a vee, parabolic, or trapezoidal channel.
 - b. The requirements for rectangular channels apply to any open channel with side slopes greater than 2 horizontal to 1 vertical and include the following:
 - i. Rectangular channels must either be constructed of concrete or gabions.
 - ii. An approved safety barrier must be placed on both sides for the length of the rectangular channel, where the channel is more than 3 feet deep.
 - iii. Care must be taken to ensure that energy dissipation is placed at the outfall of the rectangular channel to prevent erosion at the discharge point.

4.6.3.8 Channel Lining

An open channel lining shall be designed based on the cross-section, slope, and channel velocity requirements. The design may be based on a consideration of either permissive velocity or tractive force as described in the VDOT Drainage Manual.

The preferred method for analyzing channel linings is to compare the maximum permissible velocity for the channel lining, listed in the table in DCSM section 4.6.3.5, to the design velocity computed using Manning's equation to verify the selected lining is adequate. As an alternative, the selected lining may be analyzed using the Tractive Force Method in the VDOT Drainage Manual. This method analyzes critical shear loading on the open channel bottom and side slopes. The permissible tractive force for various soils is located in the Appendix of the VDOT Drainage Manual.

Open channels may have different lining materials in different channel reaches based on velocity and potential erosion conditions. Care must be exercised to avoid erosion at open channel transition points.

The open channel lining will have an impact on the design capacity in the form of the roughness coefficient. Allowable open channel linings include the following:

4.6.3.8.1 Natural

To the extent possible, natural channels shall be preserved.

To determine the permissible velocities in natural channels, based on soil conditions, use permissible velocities based on soil conditions published in the VDOT Drainage Manual. If the design storm velocity exceeds the permissible velocity, a natural channel cannot convey the stormwater runoff without modifying the discharge flow conditions or improving the natural channel.

4.6.3.8.2 Vegetative-Lined

Vegetated or grass-lined channels include man-made channels lined with established vegetation. These channels usually include a geosynthetic mat for channel stabilization for design flow velocities.

The type of grass allowable for vegetative-lined open channels is dependent on the slope of the channel and the peak calculated velocity. See the table in DCSM section 4.6.3.5 for the maximum permissible velocities for various channel linings.

A permanent channel stabilization geosynthetic mat should be considered for all vegetated channels. There is a wide variety of geosynthetic stabilization mat options from various manufacturers. The geosynthetic mat selected should be adequate for the slope and design flow velocities calculated for the channel. Where appropriate, VDOT Road and Bridge Standard EC-2 or EC-3 may be used.

Where a permanent geosynthetic mat is used to provide channel stabilization, information on the proposed mat, in the form of the manufacturer's catalog information, shall be submitted as a part of the stormwater management plan. The catalog information shall include the manufacturer's recommendations for maximum allowable velocity. Design drawings must state that the geosynthetic stabilization mat shall

be installed in strict accordance with the manufacturer's recommendations.

Where a permanent channel stabilization geosynthetic is not used, a temporary geosynthetic lining designed to provide a measure of the bed/bottom and bank stability until such time as a reasonably stable and mature stand of vegetation is established shall be provided.

4.6.3.8.3 Riprap-Lined

The use of vegetated and geosynthetic-lined open channels for mild-sloped open channels and concrete for steep-sloped open channels is encouraged. Riprap-lined channels will not be acceptable where vegetated or geosynthetic-lined open channels are feasible. However, where design flow velocities exceed the erosive capability of a natural or vegetative-lined channel, riprap may be used as a channel lining in areas where erosion is a concern. For an extended length of high velocity channel, consideration should be given to using a concrete channel rather than riprap.

Use of riprap-lined channels requires pre-approval from SID.

Where riprap is approved by SID, it shall meet VESCH Specification 3.19, VDOT Standards, and VDOT Specifications.

4.6.3.8.4 Concrete-Lined

Concrete shall be considered where design velocities dictate or where there is a need to provide the maximum level of erosion protection.

4.6.3.9 Freeboard Requirements

Open channels shall have a minimum of 6" of freeboard above the calculated water surface elevation for the design peak flow, unless the flow is supercritical. Where the flow is supercritical, a minimum of 12" of freeboard is required.

Flow is supercritical when:

$$V / (32.2 \times H)^{0.5} > 1$$

Where:

V = Velocity (fps)

H = Depth of flow (ft.)

At channel bends and curves, the freeboard shall be measured from the calculated water surface elevation, including the increased depth due to the superelevation of the water surface.

4.6.3.10 Calculation of Depth of Flow at Bends and Curves

Increases in the depth of flow occur at bends and curves due to the superelevation of the water surface. Superelevation of the water surface at bends and curves is calculated, using the VDOT Drainage Manual, by:

$$\Delta Z = V^2 / (32.2 \times r_c) \times (r_o - r_i)$$

Where:

ΔZ = Difference in water surface elevation between the concave and convex banks (ft.)

V = Average velocity (ft./sec.)

r_c = Radius of the center of the stream at the bend (ft.)

r_o = Radius of the outside bank of the stream at the bend (ft.)

r_i = Radius of the inside bank of the stream at the bend (ft.)

The increase in the normal stream flow depth at the outer bank of an open channel bend is one-half of ΔZ .

4.6.3.11 Environmental Considerations and Aquatic Organism Protection

Construction or modifications to open channels shall comply with all applicable laws and regulations. The applicant is responsible for procuring all necessary permits, such as United States Army Corps of Engineers (USACE) and DEQ wetland permits, DEQ Virginia Pollutant Discharge Elimination System (VPDES) permits, etc., prior to obtaining SID approval.

4.6.3.12 Maintenance Requirements

The Operator/Contractor is responsible for maintenance of open channels until the termination of land disturbance as described in the VTAS&S. Maintenance includes periodically pruning or mowing vegetation and removing debris.

No one shall fill, modify, or construct structural modifications that impair or restrict flow in open channels.

4.6.4 Culverts

A culvert is a single run of storm drain pipe that conveys water or stormwater under a road, railway, embankment, sidewalk, or other open channel obstruction. A culvert typically connects two open channels, but it may connect an open channel to a storm drain.

Proper culvert design must consider many factors including:

1. Design Flow
2. Inlet conditions (flow approach conditions, allowable headwater, culvert inlet configuration)
3. Culvert conditions (pipe roughness, pipe slope, diameter and length)
4. Tailwater depth
5. Buoyancy potential
6. Environmental considerations and effects on aquatic life
7. Design loads and service life of the pipe material

Refer to the VDOT Drainage Manual for a more thorough discussion of these items. For the design of stormwater inlets and storm drains, see DCSM section 4.6.5.

4.6.4.1 Design Methodology and Criteria

4.6.4.1.1 Computational Methods

Computations may be manual or by computer program.

Manual computations use design equations and nomographs. Results are documented on VDOT's Design Form LD-269.

There are a number of computer programs available to design culverts. Any of these computer programs will be acceptable if their methodologies are based on the same equations and nomographs accepted by VDOT, and if they provide the same documentation of inputs, assumptions, and output as are contained on VDOT's Design Form LD-269.

4.6.4.1.2 Design Flow Methodology

See DCSM section 4.6.2 for methodology used to determine design flows. Generally culverts shall be designed based on the peak flow (steady state), ignoring the effects of temporary upstream storage.

4.6.4.1.3 Culvert Hydraulics

4.6.4.1.3.1 Design Flow

Culverts shall be designed in accordance with the VDOT Drainage Manual, latest edition.

Compliance with the National Flood Insurance Program (NFIP) is necessary for all locations where construction will encroach on a 100-year floodplain. The Town of Blacksburg administers the NFIP on

the Virginia Tech main campus, in accordance with the Commonwealth of Virginia Executive Order 45.

In addition, the 100-year peak flow (without the addition of the obstruction allowance) shall be routed through all culverts, determining the headwater depth behind the culvert with road overtopping, to ensure that buildings and other structures are not flooded and that adjacent roadways and adjacent properties do not suffer significantly increased damage during the 100-year storm event. Storage impacts of water behind the culvert may be considered in the calculation but is not required.

4.6.4.1.3.2 Allowable Headwater

The allowable headwater is the depth of water that can be ponded at the upstream end of the culvert during the design condition, as measured from the culvert inlet invert.

The allowable headwater depth shall be limited by the following conditions:

1. Headwater does not cause upstream property damage;
2. Headwater does not increase the 100-year flood elevation, as mapped by NFIP;
3. During a design storm event, the water surface shall be a minimum of 18 inches below the shoulder of the road at the point where the culvert crosses, or the low point of the road grade where the water would overtop the road;
4. Headwater depth shall not exceed 1.5 times the diameter or height of the culvert barrel;
5. Headwater depth shall not be such that stormwater flows to other ditches or terrain, which permit the flow to divert around the culvert.
6. In most instances, the roadway overtopping may be treated as a broad crested weir.

7. The maximum overtopping depths during a 100-year storm event for various street classifications are as follows:

<u>Classification</u>	<u>Max Depth at Crown</u>	<u>Max. Velocity</u>
Local/Collector	1 ft.	6 fps
Arterial/Highway	No Overflow	No Overflow

4.6.4.1.3.3 Tailwater Conditions

Tailwater is the water into which a culvert outfall discharges. Culvert design shall be based on tailwater conditions that could reasonably be anticipated during the design condition.

1. If an upstream culvert outlet is located near a downstream culvert inlet, the headwater elevation of the downstream culvert may establish the design tailwater depth at the upstream culvert.
2. If the culvert discharges into a lake, pond, stream, or other body of water, the maximum water elevation of the body of water during the design storm may establish the design tailwater elevation at the upstream culvert.

4.6.4.1.3.4 Inlet and Outlet Control

Culvert hydraulic design shall consider both inlet and outlet control conditions. For a culvert operating under inlet control, the headwater elevation is governed by the inlet geometry. For an outlet control culvert, the inlet geometry, barrel characteristics and tailwater elevation all impact the headwater elevation.

Minimum culvert performance is determined by analyzing both inlet and outlet control for a given flow and using the highest resulting headwater.

1. Inlet Control
 - a. The following factors are considered when calculating inlet control headwater:
 - i. Inlet Area – cross sectional area of the culvert entrance face
 - ii. Inlet Edge – projecting, mitered, headwall, or beveled edges are common
 - iii. Inlet Shape – rectangular, circular, elliptical, or arch are common

- b. Nomographs for calculating headwater and flow capacity are found in the VDOT Drainage Manual.
- 2. Outlet Control
 - a. The following factors are considered when calculating outlet control headwater:
 - i. Manning's Roughness (n) – based on barrel material
 - ii. Barrel Area – cross section perpendicular to the flow
 - iii. Barrel Length
 - iv. Barrel Slope
 - v. Tailwater Elevation
 - b. Outlet control affects the hydraulic grade line of the flow through the culvert. To calculate the hydraulic grade line, reference the equations for velocity, velocity head, entrance losses, friction losses, and exit losses contained in the VDOT Drainage Manual.
- 3. For nomographs, cross sections, and pipe materials, see the VDOT Drainage Manual.

4.6.4.1.3.5 Culvert Velocity

- 1. Outlet velocity must be checked to assure that excessive erosion and scour problems will not occur.
- 2. Culvert outlet protection shall be provided in accordance with the standards and specifications for Outlet Protection and Riprap in the VESCH.
- 3. Culverts under roadways shall be provided with end sections or endwalls in accordance with the outlet protection requirements of the VDOT Drainage Manual.
- 4. Where a special design is needed to reduce outlet velocity, it shall be designed in accordance with VDOT standards.
- 5. The minimum velocity in a culvert barrel must be adequate to prevent siltation at low flow rates. At a minimum this velocity shall be 3 feet per second for a 2-year storm event.

4.6.4.1.4 Structural Design

All culverts shall be designed to withstand a HS-20 highway loading, unless it crosses under a railroad, in which case the culvert shall be designed for railroad loads. The structural design shall consider the depth of cover, trench width and condition, bedding type, backfill material, and compaction.

4.6.4.1.5 Materials

Culverts in public easements or rights-of-way shall be constructed of materials based on the following:

1. Culverts under a roadway in the right-of-way shall be VDOT approved materials.
2. Culverts under sidewalks, trails, etc., shall be reinforced concrete pipe (RCP) or high density polyethylene (HDPE).

4.6.4.1.6 Culvert Sizing and Cover

The minimum culvert size shall be 18-inch diameter.

Culverts shall meet all cover conditions required. Where the site conditions preclude the use of a single culvert barrel to meet the design flow conditions, multiple barrel culverts are acceptable.

The maximum length of a culvert shall be 300 feet. A culvert longer than 300 feet shall have manholes or junction boxes and shall fall under the requirements of DCSM section 4.6.5.

4.6.4.1.7 End Conditions

Headwalls and end sections shall normally be required on inlets and outlets, as described below.

4.6.4.1.7.1 Prefabricated End Sections

Prefabricated end sections, or flared end sections, provide for a better flow path, improving the design flow and headwater conditions.

Prefabricated end sections shall be provided for culverts from 18 to 36 inches in diameter, except:

1. Where culvert alignment exceeds 20 feet in vertical elevation change or culvert slope exceeds a 2:1 slope, a standard concrete headwall shall be provided instead of a prefabricated end section.
2. Where a concrete headwall is provided.

4.6.4.1.7.2 Concrete Headwalls and Structures

Precast concrete headwalls shall be provided at all culvert inlets and outlets, unless other end conditions are allowed, as stated above.

Precast concrete headwalls shall meet the requirements of the VDOT Road and Bridge Standards and VDOT Road and Bridge Specifications.

Wingwalls may be required in conjunction with headwalls. Culvert pipes 48" or larger in diameter shall have concrete wingwalls. Wingwalls are generally used where the culvert is skewed to the normal channel flow or where the side slopes of the channel or roadway are unstable. Wingwalls shall meet the requirements of the VDOT Standards and VDOT Specifications. Wingwalls shall be set at an angle between 30 degrees and 60 degrees from the headwall.

Concrete aprons may be used at the entrance or the exit of a culvert. Aprons are typically used where high velocities or headwater conditions may cause erosion upstream or downstream of the culvert. An apron shall not protrude above the normal stream bed elevation.

Special design concrete slab end treatment, per VDOT Standards, may be used as a concrete end section.

4.6.4.1.8 Multiple Barrel Culverts

Multiple barrel culverts shall be allowed where single culverts cannot handle the design flow while meeting the required cover or headwater condition requirements. The design of multiple barrels should avoid the need for excessive widening of the upstream or downstream receiving channels.

The minimum spacing between culverts in a multiple barrel culvert design shall be that required to provide adequate lateral support and allow proper compaction of bedding material under the pipe haunches.

4.6.4.1.9 Culvert Skew

Where possible, culverts shall be installed parallel to the flow path. The maximum allowable skew shall be 45 degrees as measured from the line perpendicular to the roadway centerline.

4.6.4.1.10 Buoyancy

Verify that the culvert pipe, end sections, and concrete endwall structures will not fail under hydrostatic uplift conditions.

The buoyancy force consists of the weight of water displaced by the pipe and the fill material that is over the pipe (below the headwater depth). The force resisting buoyancy includes the weight of the pipe, weight of the water within the pipe, and the weight of fill material over the pipe.

Buoyancy is more likely to be a problem where:

1. Lightweight pipe is used

2. The pipe is on a steep slope (usually inlet control with the pipe flowing partially full)
3. There is little weight on the end of the pipe (flat embankment slopes, minimum cover, and/or no endwalls)
4. High headwater depths ($HW/D > 1.0$)

Suitable cover, footings, or anchor blocks may be required to ensure the culvert's integrity during design conditions.

4.6.4.1.11 Debris and Trash Racks

In general, trash racks or debris deflectors shall not be used where other site modifications may be made to prevent excessive trash or debris from entering the culvert. However, they may be required at specific locations by SID where large amounts of storm debris may be anticipated.

4.6.4.2 Installation

All culvert pipe, headwalls, end sections, outlets, and other peripheral structures shall be installed in accordance with VDOT requirements and the manufacturer's recommendations. The characteristics of the trench, bedding, and pipe material all impact the structural strength of the pipe system. The installed culvert conditions shall comply with the design assumptions and calculations.

4.6.4.2.1 Bedding Material

Bedding material and installation shall comply with the requirements of the VDOT Specifications.

4.6.4.2.2 Backfill

Backfill shall be suitable material and shall be placed and compacted in accordance with VDOT Specifications.

A minimum of 12" of backfill shall be placed over the top of a HDPE or corrugated metal pipe (CMP) culvert prior to placing pavement or other surface treatment.

4.6.4.3 Environmental Considerations and Aquatic Organism Protection

Where compatible with good hydraulic engineering, a culvert shall be located in "dry" conditions. Where this is not possible, the culvert shall be located to minimize impacts to streams or wetlands.

When a culvert is set in a perennial stream, the invert of the culvert shall be set below the normal flow line of the stream as required in the VDOT Drainage Manual. The grade of the culvert shall not exceed the grade of the natural stream in that section.

Where construction requires environmental permits, the applicant shall be responsible for obtaining all necessary environmental permits and complying with their requirements.

4.6.4.4 Maintenance Requirements

The Operator is responsible for maintenance of culverts until the termination of land disturbance as described in the VTAS&S.

4.6.5 Storm Drains

A storm drainage system consists of two or more interconnected pipes and one or more structures designed to intercept and convey stormwater runoff from specific storm event without surcharge. Storm drains collect and transport stormwater from a site primarily through the use of a closed pipe network. For the stormwater to be efficiently handled in a storm drain, the site must also have an efficient way to collect stormwater runoff and have it enter into the piped network. Once in the storm drain, the stormwater is routed to a discharge outfall.

Storm drainage systems include:

1. Inlets
2. Storm drain piping and structures that convey stormwater runoff to the outfall

This section defines criteria and restrictions that shall be used in designing and constructing storm drains. See the VDOT Drainage Manual for more in-depth information.

Profiles for all storm drains 12 inches in diameter and greater shall be provided on the site plans.

4.6.5.1 Design Methodology and Criteria

4.6.5.1.1 Computational Methods

Computations may be manual or by computer program.

Manual computations use design equations and nomographs. Results may be documented on VDOT work sheets.

1. Form LD-204, Stormwater Inlet Computations
2. Form LD-229, Storm Drain Design Computations
3. Form LD-347, Hydraulic Grade Line Computations

There are a number of computer programs available to design storm drainage systems. Any of these computer programs will be acceptable if their methodologies are based on the same equations and nomographs accepted by VDOT, and if they provide the same documentation of inputs, assumptions, and output as are contained on VDOT's work sheets.

Computational methods are explained in detail, including comprehensive design examples, in the VDOT Drainage Manual.

4.6.5.1.2 Hydrology

See DCSM section 4.6.2 for the methodology used to determine design flows. Calculations establishing the design flow shall be submitted with the Stormwater Management Plan. Design flows shall be based on the ultimate build-out of the project, or of the campus precinct in accordance with the Virginia Tech Stormwater Management Master Plan.

4.6.5.1.3 Design Flows

Inlets shall be designed for 10-year storm frequencies and intensities consistent with the VDOT Drainage Manual.

Storm drains shall be designed in accordance with DCSM section 4.6.2.

4.6.5.1.4 Measures to Convey Stormwater Runoff to Inlets

4.6.5.1.4.1 Curb and Gutter

Curb and gutter at the edge of pavements may be used to collect stormwater runoff from roadways. Curbing captures stormwater runoff and directs it to stormwater collection inlets while protecting adjacent properties from flooding and erosion due to sheet flow runoff from the impervious roadways.

A curb and gutter forms a triangular conveyance channel. When a storm occurs, the runoff from the road creates a spread of water from the curb. The curb and gutter must be designed to convey this flow and with associated drainage structures prevent the spread onto the roadway from impacting traffic. The spread width of flow is determined by using nomographs. For curb and gutter flow, a Manning's n value of 0.015 is used in the computational analysis.

Curb and gutter dimensions and design shall meet VDOT Standards.

4.6.5.1.4.2 Open Channels

Open channels may be used to collect site drainage and convey it to a storm drain inlet. Design requirements for open channels are covered in DCSM section 4.6.3.

4.6.5.1.5 Storm Drain Inlets

4.6.5.1.5.1 General

Storm drain inlets are used to collect stormwater runoff from roads, sidewalks, or low elevations during storm events and provide a method for conveying the stormwater into the storm drain system. This is usually accomplished by placing storm drain inlets at regular intervals or at key locations to intercept flows and control the stormwater spread width. The design criteria for limiting the spread of water on travel lanes is found in the VDOT Drainage Manual.

There are several different types of storm drain inlets that can be used to meet this purpose, and the designer shall choose the proper inlet structure based upon site conditions and design conditions to maximize the drainage efficiencies.

1. Curb
2. Grate
3. Slotted Drain/Trench
4. Combination

Stormwater management plans shall include a contour plan with sufficient contours shown to ensure positive drainage to an inlet. Inlet Volume Capacity Calculations are required with the Stormwater Management Plan submittal.

4.6.5.1.5.2 Curb Inlets

Curb inlets are vertical openings in the curb covered by a top slab. These inlets can convey large quantities of water, but also allow for large amounts of debris to enter the storm drain system.

Curb inlets shall be used to the maximum extent possible for pavement drainage.

4.6.5.1.5.3 Grate Inlets

Grate inlets are horizontal grates that are usually used in depressed medians or in other areas of low elevations. Grate inlets are often referred to as drop inlets or DIs. Grate inlets shall be pedestrian rated when installed in paved areas. Where they are used in pavement, inlet grates shall be bicycle safe.

4.6.5.1.5.4 Combination Inlets

Combination inlets combine both the vertical opening used by curb inlets and the horizontal grate used by grate inlets. These inlets are often used when the inlet chamber is required to be under the gutter or street pavement away from the sidewalk or other utilities. Combination inlets shall be avoided where possible. Where they are used, they must have bicycle-safe grates.

4.6.5.1.5.5 Trench Drain Inlets

Trench drain inlets are cast-in-place or precast concrete trenches covered by a grate that are used to intercept sheet flow.

4.6.5.1.5.6 Inlet Locations

Inlets shall be located to meet the design requirements of the VDOT Drainage Manual for maximum spread width. In addition, inlets shall be provided, regardless of contributing drainage area, as follows:

1. At sag points in the gutter grade.
2. Either side of sag point inlet (flanking inlets).
3. Upstream of median breaks, crosswalks, and street intersections.
4. Immediately upstream and downstream of bridges.
5. On side streets at intersections, where flow is approaching the main line.
6. Behind curbs, shoulders, or sidewalks to drain low areas or intercept concentrated flow.
7. At 1% cross slope upstream of cross slope reversals.
8. At any low elevation in the grade.

Inlets installed in pathways likely to be used by pedestrians or bicyclists shall be a pedestrian rated grate.

4.6.5.1.5.7 Access

All inlets shall have a removable grate or manhole cover to allow access for clean out.

4.6.5.1.5.8 Inlet Capacities

The capacities of each inlet type are contained in the VDOT Drainage Manual. Capacities are determined from equations or nomographs that are contained within the VDOT Drainage Manual. Documentation of inlet capacity shall be made on VDOT Form LD-204, Stormwater Inlet Computations or computer modeling output.

4.6.5.1.5.9 Separation of Pipes

Where two or more storm drains enter a concrete structure at or near the same elevation, a 6" minimum horizontal clearance must be maintained between the pipes. Additional clearance between pipes shall be provided if required to protect the structural integrity of the structure.

4.6.5.1.6 Storm Drain Pipes

4.6.5.1.6.1 Flow Capacity

Based on the size and slope of the storm drain, the design capacity for a pipe flowing full can be determined using Manning's equation.

$$Q = A \times 1.49/n \times R^{2/3} \times S^{1/2}$$

Where:

Q = Flow in the pipe (cfs)

A = Cross-sectional Area of the pipe (sq. ft.)

R = Hydraulic radius; for circular pipe flowing full, R = Diameter/4 (ft.)

S = Storm drain slope (ft./ft.)

n = Pipe roughness coefficient

The design flow capacity of a storm drain shall comply with the design frequencies set forth in the VDOT Drainage Manual. In a roadway underpass, or depressed section, where ponded water can only be removed through the storm drain system, a 100-year frequency storm event shall be used to design the storm drain at the sag point.

4.6.5.1.6.2 Storm Drain Slope

To deter the settling of debris and sediment in the storm drain pipe, the pipe shall be designed to ensure positive slope and maintain a minimum velocity of 3 feet per second during a 2-year frequency storm.

The maximum pipe velocity in any storm drain shall be 20 feet per second during a 10-year frequency storm to prevent excessive abrasion of the pipe and erosion at the discharge. If the pipe velocity exceeds 15 feet per second during a 10-year frequency storm, a reinforced concrete storm drain pipe is required.

Storm drains shall be sloped to meet the velocity requirement set in this chapter. Slopes greater than 16% shall be avoided if possible. If unavoidable, drop structures shall be utilized in steeper terrain. In addition, storm drains with slopes steeper than 16% must have anchor blocks for support.

4.6.5.1.6.3 Pipe Size

The minimum recommended conduit size for storm drainage pipe is 15-inch diameter or its equivalent for non-circular shapes. Where necessary, it will be permissible to use a 12-inch diameter pipe for laterals or initial pipe runs of 50 feet or less. Pipe size shall not be reduced along the direction of the flow, except as required for proper operation of stormwater management facilities.

4.6.5.1.6.4 Access

Regardless of pipe size, a cleanout access point, either an inlet, manhole, or junction box shall be provided at a maximum of every 300 feet of pipe.

4.6.5.1.6.5 Water-Tight Joints

The use of water-tight joints is encouraged to prevent infiltration of groundwater, and potential pollutants carried by contaminated groundwater, and to prevent settlement problems from occurring due to soil materials washing into storm drains.

SID reserves the right to require the use of water-tight joints in the following locations:

1. Culverts and storm drains under pavement, sidewalks, or concrete structures
2. Through stormwater “hotspots”
3. In areas where groundwater may be contaminated by pollutants
4. On steep slopes
5. Culverts

The following land uses and activities are designated as stormwater hotspots:

1. Vehicle salvage yards and recycling facilities
2. Vehicle fueling stations
3. Vehicle service and maintenance facilities
4. Vehicle and equipment cleaning facilities
5. Fleet storage areas (bus, truck, etc.)
6. Industrial sites (for SIC codes contact Virginia DEQ)
7. Marinas (service and maintenance areas)
8. Outdoor liquid container storage
9. Outdoor loading and unloading facilities
10. Public works storage areas
11. Facilities that generate or store hazardous materials
12. Commercial container nursery
13. Golf courses
14. Chemical storage
15. Dry cleaning operations

4.6.5.1.7 Determination of Hydraulic Grade Line

The hydraulic grade line represents the free water surface elevation of water in a pipe system. Where the hydraulic grade line is above the top of a pipe, the pipe is flowing under pressure. The hydraulic grade line in a manhole or other structure is the elevation to which water will rise.

Hydraulic grade lines shall be calculated and evaluated for all storm drains. The hydraulic grade line shall be calculated using VDOT methods and equations that are fully described in the VDOT Drainage Manual. Calculations shall be documented on VDOT Form LD-347, Hydraulic Grade Line Computations, or computer modelling output. The output shall be in the form of profiles showing the HGL in relation to the pipe and structures.

The hydraulic grade line shall not exceed any critical elevation during the design storm. Critical elevations include rising above the ground elevation at inlets or other structures, or reaching an elevation where storm flow could back up to cause flooding damage.

The calculation of the hydraulic grade line begins at the system outfall and proceeds upstream to each structure in the system. The calculation is based on the principal of conservation of energy as shown below and includes major and minor energy losses:

$$\text{HGL}_{\text{US}} = \text{HGL}_{\text{DS}} + H_f + H_m$$

Where:

HGL_{US} = Elevation of hydraulic grade line at the upstream structure

HGL_{DS} = Elevation of hydraulic grade line at the downstream structure

H_f = Pipe friction loss

H_m = Summation of minor head losses (junctions, bends, etc.)

Major head losses are attributable to friction losses within the pipe.

Minor head losses include losses from:

1. Junctions
2. Exits
3. Entrances
4. Bends in Pipes
5. Access holes
6. Conflict pipes
7. Plunging flow
8. Expansions and contractions
9. Appurtenances such as weirs, diverters, valves and meters

4.6.5.1.7.1 Outfall Conditions

The hydraulic grade line starts at the system outfall. At this point the hydraulic grade line shall be the actual tailwater elevation or the elevation of 0.8 times the diameter of the outlet pipe, whichever is higher. If the system discharges into a detention or retention pond, the hydraulic grade shall start at the 10-year water surface elevation.

4.6.5.1.7.2 Pipe Friction Losses

The friction slope is the energy slope for that run of pipe. The friction slope is determined by inserting pipe information and design flow into Manning's equation and solving for S (slope). The total friction head loss in the run of pipe is the friction slope multiplied by the length of the run.

Where the hydraulic grade line falls below the crown of the pipe, the elevation of normal flow is the hydraulic grade line.

4.6.5.1.7.3 Junction Losses

Junction head losses are the summation of entrance (H_i), exit (H_o), and bend losses (H_{Δ}). When calculating junction losses it is important to use actual flow velocities. If pipes are flowing partially full, then partially full velocities are used.

1. Entrance (Expansion) Losses

Entrance loss at a junction is given by:

$$H_i = K_e (V_i^2 / 2g)$$

Where:

H_i = Entrance head loss

K_e = Entrance loss coefficient. $K_e = 0.35$

V_i = Velocity in the inlet pipe. Where more than one inlet pipe is present, use the velocity from the pipe that has the greatest momentum ($Q \cdot V$)

g = Gravitational acceleration constant, 32.2 ft./sq. sec.

2. Exit (Contraction) Losses

Exit loss at a junction is given by:

$$H_o = K_o (V_o^2 / 2g)$$

Where:

H_o = Exit head loss

K_o = Exit loss coefficient. $K_o = 0.25$, except that $K_o = 0.3$ when computing the loss leaving the initial inlet

V_o = Velocity in the outlet pipe

g = Gravitational acceleration constant, 32.2 ft./sq. sec.

3. Bend Losses

a. Bend losses at a junction are dependent on the angle between the inlet and outlet pipes. If the inlet and outlet pipe are in line with one another (no bend), the angle is 0 degrees and there is no bend loss. As the angle increases towards 90 degrees, the bend loss increases. Storm drain systems should not be designed with bend angles greater than 90 degrees. Where more than one pipe enters a junction at an angle, the H_{Δ} should be figured on all bends and the largest one used as the bend loss.

b. The bend loss is given by:

$$H_{\Delta} = K (V_i^2 / 2g)$$

Where:

H_{Δ} = Head loss at bend

K = Bend loss coefficient. K is determined by consulting Figure 9-9 in the VDOT Drainage Manual.

V_i = Velocity in the inlet pipe.

g = Gravitational acceleration constant, 32.2 ft./sq. sec.

4. Plunging Losses

Where surface inlet inflow is 20 percent or more of the total flow through a junction, or when a lateral pipe enters a junction with its invert elevation above the crown of the outgoing pipe and the flow in the lateral pipe is 20 percent or more of the total flow through the junction, the total head loss from the structure ($H_i + H_o + H_{\Delta}$) shall be multiplied by 1.3 (increased by 30 percent). This adjustment is cumulative with the adjustment for plunging losses.

5. Inlet Shaping

Inlet shaping refers to how the invert is shaped to provide smooth flow through the structure and is required in all manholes and inlets. When VDOT Standard IS-1, inlet shaping, is used in a structure, the total head loss from the structure ($H_i + H_o + H_{\Delta}$) shall be multiplied by 0.5 (decreased by 50 percent). This adjustment is cumulative with the adjustment for inlet shaping.

4.6.5.1.8 100-Year Conditions

Where there is the possibility of building structures flooding, conditions during the 100-year storm shall be analyzed to verify that all existing and proposed structures do not flood. Flow from the 100-year storm may be carried overland as well as by the storm drain system.

4.6.5.1.9 Materials

4.6.5.1.9.1 Structures

All stormwater structures (inlets, manholes, and junction boxes) located in public easements or rights-of-way shall be precast or cast-in-place concrete. All structures, frames, grates, and covers shall be in accordance with VDOT Standards and VDOT Specifications.

4.6.5.1.9.2 Storm Drain Pipe

Storm drain pipe in roadways shall be constructed of RCP. Storm drain pipe in sidewalks, trails, etc., shall be constructed of RCP or HDPE. CMP shall not be allowed.

4.6.5.1.10 Structural Design

All inlet structures, frames and grates; and pipes shall be designed to withstand a HS-20 loading, unless a pipe crosses a railroad, in which case the pipe shall be designed for railroad loads. The structural design shall

consider the depth of cover, trench width and condition, bedding type, backfill material, and compaction.

4.6.5.2 Installation

All inlets, pipes, and associated structures shall be installed in accordance with VDOT Specifications and the manufacturer's recommendations. The characteristics of the trench, bedding, and pipe material all impact the structural strength of the pipe system. The installed pipe conditions shall comply with the design assumptions and calculations.

4.6.5.2.1 Bedding Material

Bedding material and installation shall comply with the requirements of the VDOT Specifications.

4.6.5.2.2 Backfill

Backfill shall be suitable material and shall be placed and compacted in accordance with the VDOT Specifications.

Before passage of equipment, a minimum of 12 inches of cover shall be placed over the top of a storm drain pipe prior to placement of pavement or other surface treatment. Additional depth of cover shall be provided if recommended by the manufacturer.

4.6.5.2.3 Separation of Utilities

Where storm drains cross other utilities, at least 1 foot of vertical separation shall be provided. Where 1 foot of vertical separation cannot be provided, special provisions shall be made in the bedding and backfill to avoid settlement that could cause point loadings on the storm drain or other utility.

Waterlines and sewer lines shall not pass through a storm drain inlet or manhole.

4.6.5.3 Environmental Impacts

Construction or modifications to storm drains shall comply with all applicable laws and regulations. The applicant is responsible for procuring all necessary permits.

4.6.5.4 Erosion Protection at Outfalls

Erosion protection at storm drain outlets shall be provided in accordance with the outlet protection standards contained in the VESCH and the VDOT Drainage Manual.

4.6.5.5 Maintenance Requirements

The Contractor is responsible for maintenance of storm drains until the termination of land disturbance as described in the VTAS&S.

4.6.6 Stormwater Detention

Stormwater detention facilities are a means of attenuating increases in peak flow rates caused by land development. In addition to providing flood control, stormwater detention facilities can protect downstream channels from increases in erosion and may provide a measure of water quality treatment. This chapter addresses general requirements for detention facilities as they relate to attenuating peak flow rates.

When a storm event occurs, stormwater runoff enters the detention facility. The outlet structure allows a portion of the stormwater runoff to discharge from the facility, while the remainder of the stormwater runoff is temporarily stored. After the end of the storm, water continues to discharge from the facility until it is empty or the permanent pool elevation is reached.

Stormwater detention facilities, as listed in Virginia Stormwater BMP Clearinghouse and DEQ Stormwater Regulations, include:

1. Proposed Facilities (Under Part IIB)
 - a. Bioretention (Including Urban Bioretention)
 - b. Constructed Wetlands
 - c. Wet Ponds
 - d. Extended Detention Ponds
 - e. Underground Detention Facilities
2. State Existing Facilities (Under Part IIC)
 - a. Detention Basin
 - b. Enhanced Extended Detention Basin

An underground detention facility consists of pipes or manufactured underground chambers used to temporarily store stormwater runoff following a storm event, discharging it at a controlled rate through a hydraulic outlet structure to a downstream conveyance system. An underground detention facility is dry during non-rainfall periods.

In addition to detention, the design requirements specified by this chapter shall apply to ponds created as amenities, research ponds, and farm ponds.

4.6.6.1 Design Methodology and Criteria

4.6.6.1.1 Hydrology

See DCSM section 4.6.2 for methodology used to determine design flows.

4.6.6.1.2 Design Flows and Storage Volumes

To properly design stormwater detention facilities, a flow routing program shall be used with an appropriate elevation-storage-discharge relationship for the design storm events.

4.6.6.1.3 Detention Facility Locations

Stormwater detention facilities should not be constructed within a Federal Emergency Management Agency (FEMA) designated 100-year floodplain. If this is unavoidable, the facility shall comply with all applicable regulations under the National Flood Insurance Program, 44 CFR 59.

The following factors shall be addressed when siting a stormwater detention facility:

1. Geotechnical conditions, including soil conditions
2. Karst topography
3. Groundwater levels
4. Existing and proposed utilities
5. Aesthetic impacts on surrounding properties
6. Environmental impacts, including wetlands

Stormwater basins shall be located to minimize the aesthetic impacts to adjacent properties. Basins shall be set back from property lines a distance equal to the minimum width of the applicable required Source in accordance with Virginia Stormwater BMP Clearinghouse Specification No. 15.

Locate stormwater detention facilities to avoid collecting significant amounts of drainage from offsite areas.

All stormwater management basins shall be lined with either a clay liner or an impermeable HDPE liner.

4.6.6.1.4 Detention Basin Grading

Stormwater basins shall be graded to blend into the surrounding topography with the following conditions:

1. Basin side slopes shall be no steeper than 3H:1V.
2. Provisions shall be made for the long-term maintenance of basin slopes and periodic access for maintenance of the outlet structure and emergency spillway and removal of accumulated sediment and debris.
3. The maximum allowable depth of a stormwater detention basin shall be 15 feet, as measured from the top of the embankment to the lowest point in the basin.
4. The bottom of the basin shall be designed so that the entire bottom of the Extended Detention Basin is sloped at 1 percent to facilitate positive drainage to the outlet structure.

In addition to the above requirements, the following standards of practice should be used when designing a stormwater basin, to the extent possible:

1. In order to prevent short-circuiting of a stormwater basin's sediment storage areas, the length-to-width ratio of the basin should be a minimum of 2:1, with the flow entering the basin as far from the outlet structure as possible. A 3:1 ratio is desired where possible.
2. To minimize cut and fill, the long dimension of a stormwater basin should run parallel to the contours.

4.6.6.1.5 Embankments and Emergency Spillways

Embankments and emergency spillways shall be designed in accordance with the Earthen Embankment and Vegetated Emergency Spillway specifications on the Virginia Stormwater BMP Clearinghouse. A geotechnical study for the embankment and basin is required.

4.6.6.1.6 Outlet Structures and Release Rates

4.6.6.1.6.1 Stormwater Release Rates

Stormwater detention facilities shall be designed with an outlet structure to control the release rate of stormwater being held in the facility. Design release rates shall meet the requirements set forth in DCSM section 4.6.6.

Research ponds, farm ponds and ponds created as amenities shall be exempt from release rate requirements.

4.6.6.1.6.2 Outlet Structure Criteria

Outlet structures generally include a principal spillway and an emergency spillway. An outlet structure may take the form of combinations of risers, pipes, weirs, or orifices. The principal spillway is intended to release flow from the design storm events at the necessary controlled rate, without allowing flow to enter the emergency spillway. The sizing of the outlet structure shall be based on the results of the hydrologic routing calculations or model. Due to the tendency of clogging, the minimum orifice diameter shall be 3 inches. A basin drain shall be installed to allow for dewatering.

Outlets from stormwater detention facilities shall be designed to function without manual, electrical, or mechanical controls.

Where necessary, energy dissipaters shall be placed at the outfall to provide a non-erosive velocity from the facility to a channel. See DCSM section 4.6.7 for the design of outfall protection.

Where a stormwater basin with an earthen embankment does not have an emergency spillway, the principal spillway shall be sized to safely pass the flow from the 100-year storm without overtopping the embankment. In addition, the minimum diameter of the primary spillway inlet shall be 24 inches.

Freeboard for detention basin facilities are as follows:

1. 1' of freeboard for basins that have an emergency spillway that is measured from the calculated design water surface elevation to the top of the embankment; or
2. 2' of freeboard for basins that do not have an emergency spillway that is measured from the calculated design water surface elevation to the top of the embankment.

Where a stormwater basin has an outfall with an emergency spillway, the outfall shall be sized to safely pass the flow from the 10-year storm and the emergency spillway shall be sized to safely pass the 100-year storm. For a stormwater basin that does not have an emergency spillway, the outfall shall be sized to safely pass the flow from the 100-year storm.

For examples of design calculations of outlet structure orifices and weirs, see the VDOT Drainage Manual.

All riser structures shall be cast-in-place, precast concrete, or PVC unless a substitute material has been approved by SID. Standards for riser structures may be found in the VDOT Standards. Riser buoyancy calculations are required.

Outlet pipes shall be reinforced concrete pipe with rubber gasket watertight joints, shall have appropriate seepage control, and shall be installed on a concrete cradle from the toe of the pipe to the riser for the entire length of the outfall pipe. Concrete cradle shall be in accordance with the requirements of the VDOT Standards.

4.6.6.1.7 Landscaping

Stormwater basin embankments shall be stabilized. Plant selection and installation shall be in accordance with the standards of the Virginia Stormwater BMP Clearinghouse specifications. Trees and shrubs shall not be planted within a stormwater detention basin, nor on a stormwater basin berm, dam, or emergency spillway.

Native plants will be used to the maximum extent possible.

4.6.6.1.8 Underground Detention

4.6.6.1.8.1 Materials

All materials used in underground detention facilities shall be corrosion-resistant, consisting of reinforced concrete, corrugated HDPE pipe, or similar approved material.

4.6.6.1.8.2 Slope

Underground detention facilities shall be sloped to drain at a minimum floor slope of 1 percent.

4.6.6.1.8.3 Capacity

Underground detention facilities and other storm drainage system and facility components shall be sized such that the 100-year design storm may be routed through the drainage system and facilities with no damage to the surface property.

4.6.6.1.8.4 Accessibility and Maintainability

All underground detention facilities shall be designed to be readily accessible for periodic inspection and maintenance from the surface without the need to perform confined space entry.

Providing pre-treatment to remove sediments before or at the entrance of the underground detention facility to improve water quality and/or improve maintainability shall be included to the maximum extent practicable in the design.

4.6.6.1.9 Trash Racks

Outlet structures shall be equipped with an appropriate trash rack. The trash rack shall be in accordance with the VSWMH.

4.6.6.2 Environmental Impacts

Environmental impacts shall be carefully considered when designing stormwater detention facilities. Stormwater detention facilities shall be designed in accordance with MS-14. Proposing basins in low-lying areas with potentially environmentally sensitive areas requires careful consideration, coordination, approval, and permitting with SID and state and federal agencies to evaluate the suitability of constructing in these areas.

Environmentally sensitive areas include, but are not limited to wetlands, shallow marshes, jurisdictional waters, natural watercourses, wildlife habitat, etc., and may be protected by state and/or federal laws. With careful planning, it may be possible to incorporate wetland mitigation into the basin design.

Construction of stormwater basins or modifications to existing basins shall comply with all applicable laws and regulations. The applicant is responsible for procuring all necessary permits, such as U.S. Army Corps of Engineers and Virginia DEQ wetland permits, Virginia DEQ VPDES permits, etc., and providing SID with the permit documentation prior to beginning construction.

Detention facilities may be coordinated with a Virginia Tech regional stormwater management plan or the Virginia Tech Stormwater Management Master Plan.

4.6.7 Energy Dissipation

Outlet protection for culverts, storm drains, BMP outlets, and steep open channels is essential to prevent high velocity flows from eroding downstream channels and damaging drainage structures. Erosion problems at culverts or at the outlets of detention basins are a common occurrence. Determination of the flow conditions, scour potential, and channel erosion resistance shall be standard procedure for all designs.

Outlet protection can be a channel lining, structure, or flow barrier designed to lower excessive flow velocities and prevent erosion and scour.

Outlet protection shall be employed whenever the velocity of flow at a pipe or open channel outlet exceeds the erosive velocity of the immediate downstream reach.

Energy dissipation may take the form of the following:

1. Erosion control stone outlet protection.
2. Erosion control stone-lined channels
3. Riprap outlet basins
4. Concrete baffled outlets

4.6.7.1 Design Methodology and Criteria

4.6.7.1.1 Outlet Velocity

Where the outlet velocity from culverts, storm drain outfalls, or open channels is high, and channel or pipe modifications cannot adequately reduce the velocity, energy dissipation may be necessary. See the VDOT Drainage Manual and/or the VESCH for methodologies to determine design outlet velocities from open channels, culverts, and storm drains.

4.6.7.1.2 Erosion Control Stone

The most common form of energy dissipation is the use of erosion control stone at the outlet. Protection is provided primarily by having sufficient length and flare to dissipate energy by expanding the flow. The outlet velocities are computed for the 10-year discharge.

Where a pipe discharges into a channel, the apron shall extend across the channel bottom and shall extend up the bank to a depth of one foot above the maximum tailwater depth from the design storm event. The dimensional requirements of the erosion control stone apron shall be determined using the graphical curves in the VESCH.

Generally, the use of erosion control stone for energy dissipation is limited to a maximum velocity of 19 feet per second. Alternative means of energy dissipation shall be required where the discharge velocity is greater than 19 feet per second. Alternative means include riprap stilling basins or concrete baffled outlets. The use of alternative means of energy dissipation requires the approval of VDOT when located in a VDOT right-of-way.

4.6.7.1.3 Riprap Basins

A riprap outlet basin is a depressed area of riprap placed at the outlet of a high velocity culvert, storm drain or open channel. The riprap reduces the exit velocity by expanding the flow over the riprap length and width and forming a hydraulic jump.

For the design of riprap basins, refer to the VDOT Drainage Manual. Dissipator geometry may also be computed using the “Energy Dissipator” module that is available in the computer program FHWA HY8, Culvert Analysis.

4.6.7.1.4 Baffled Outlets

A baffled outlet usually consists of a concrete box structure with a vertical hanging concrete baffle and an end sill. Several variations of concrete baffled outlets have been published by VDOT and other state and local transportation and stormwater management agencies. Baffled outlets are usually used when very high exit velocities exist at piped or channel transitions. Baffled outlets function by dissipating energy through impact of the water hitting the baffle and through the resulting turbulence. A tailwater depth is not required for adequate energy dissipation, but will help smooth the outlet flow.

This type of outlet protection may be used with outlet velocities up to 50 feet per second.

Baffled outlets are not included in the state guidance handbooks. Hydraulic design procedures for baffled outlets may be found in the U.S. Department of Interior, Bureau of Reclamation, Design of Small Canal Structures, 1978.

4.6.7.1.5 Additional Energy Dissipators

For additional energy dissipators, refer to FHWA HEC No 14, Hydraulic Design of Energy Dissipators for Culverts and Channels.

4.6.7.2 Installation Requirements

Energy dissipators shall be installed and constructed according to all applicable FHWA, VDOT, and state requirements and recommendations.

4.6.7.3 Environmental Impacts

Construction or modifications to energy dissipation structures shall comply with all applicable laws and regulations. The applicant is responsible for

procuring all necessary permits, such as U.S. Army Corps of Engineers permits, Virginia DEQ wetland permits, etc.

4.6.7.4 Maintenance Requirements

The Operator/Contractor is responsible for maintenance of energy dissipation structures in accordance with VESCH standards until the termination of land disturbance as described in the VTAS&S.

4.6.8 Stormwater Pollutant Removal Practices

A wide variety of BMPs and general development strategies may be utilized to remove environmentally harmful pollutants from stormwater runoff. Allowable BMPs are listed on the Virginia Stormwater BMP Clearinghouse.

4.6.8.1 Stormwater Quality Requirements

Stormwater runoff generated from land disturbing activities shall be treated through best management practices designed to remove pollutants from the stormwater. The required pollutant removal shall be dependent on the land cover conditions.

For most projects, the BMPs will be designed to remove phosphorus from the stormwater runoff. Generally, when a BMP is efficient in removing phosphorus from the stormwater runoff, it is assumed that easier to remove pollutants such as heavy metals and total suspended solids have also been adequately removed.

When a site drains to more than one Hydrologic Unit Code (HUC), the pollutant load reduction requirements shall be applied independently within each HUC, unless reductions are achieved in accordance with a comprehensive stormwater management plan.

Where appropriate, additional pollutants may be required to be removed from the stormwater runoff based on the presence of stormwater hotspots (land use activities that generate highly contaminated runoff, as determined by SID). See DCSM section 4.6.5.1.6.5. These pollutants may include the following:

1. Total Suspended Solids, in areas with highly erodible soils.
2. Total Petroleum Hydrocarbons (TPH), fueling stations or areas with fuel-contaminated soil.
3. Heavy Metals, in areas with contaminated soils.
4. High temperature runoff.

Land disturbing activities shall also comply with all additional water quality requirements as indicated in the VTAS&S, current version.

Proposed Common Plan developments shall apply stormwater quality management criteria to the land development project as a whole. Individual projects in Common Plan developments shall not be considered separate land development projects in regards to water quality. Hydrologic parameters shall reflect the ultimate land development and shall be used in all engineering calculations.

Where stormwater quality requirements must be implemented, stormwater runoff must flow through appropriate BMPs before the water is discharged from the site.

4.6.8.2 Stormwater Quality Calculations

To meet the requirements of the VSMP regulations, the Virginia Runoff Reduction Method (VRRM) will be utilized to verify compliance. The VRRM water quality compliance worksheet is available on the DEQ website. This worksheet must be submitted in the Stormwater Management Plan. The average one-year rainfall depth shall be 43 inches.

4.6.8.3 Manufactured BMP Systems

A manufactured BMP system is a structural measure that is specifically designed and sized by a manufacturer to intercept stormwater runoff and prevent the transfer of pollutants downstream. Use of manufactured BMPs will only be allowed if the device is approved and listed on the Virginia Stormwater BMP Clearinghouse.

4.7 UTILITIES

Future subterranean utility improvements should be buried at a sufficient depth (typically 30 inches) to allow for regrading of nearby slopes without requiring relocation of the improvement. Grading operations shall not result in utilities being buried at an unreasonable depth without prior approval from Mechanical Utilities.

4.7.1 Manholes and Structures

4.7.1.1 References

The following ASTM standards provide specifications for this section:

A48 – Standard Specification for Gray Iron Castings

C443 – Standard Specification for Joints for Concrete Pipe and Manholes, Using Rubber Gaskets

C478 – Standard Specification for Circular Precast Reinforced Concrete Manhole Sections

4.7.1.2 Materials

1. General – Concrete manholes and utility structures shall be of precast construction. All concrete shall be rodded or vibrated to minimize honeycombing and assume water tightness. Items delivered and installed at the site shall be structurally sound and free from cracks or major surface blemishes.
2. Precast Concrete Manholes:
 - a. Precast manhole shall conform to ASTM C478 and the standard details referred to on the plans.
 - b. Minimum inside diameter shall be 48 inches unless noted on plans with minimum of 5-inch thick walls. All manholes shall have monolithic bases except as shown on the plans.
3. Manhole Steps: Plastic coated steps only shall be provided in all manholes and shall be on 12-inch minimum centers. Steps shall conform to OSHA requirements for manhole step detail.
4. Pipe:
 - a. Provision for indicated storm drainage pipe connections shall be made by means approved in VDOT Specification 302.
 - b. Sanitary sewer pipe connections shall be made with flexible watertight rubber connector fastened to the pipe with a stainless steel band. Connector shall be in accordance with ASTM C923.
 - c. All lines shall be grouted into place.
5. Frames and Covers: Frames and covers shall be of cast iron conforming to ASTM A48 for Class 30 Gray Iron and shall conform to VDOT (or watertight where indicated on plans) manhole cover and frame detail.
6. Concrete: Concrete used for shaping of manholes, channels, sidewalk, and miscellaneous work shall meet requirements of VDOT type A3 or C1.
7. Inlet Structures: Curb opening and grate opening inlets shall be provided as shown on the plans and shall conform to VDOT Specification 302. All inlets shall be precast and shall conform to the VDOT Road and Bridge Standards.
8. Steam Manhole:
 - a. Steam manholes shall be designed with sump pumps.
 - b. Steam manholes shall be designed with a drip leg that runs to a flash tank with a steam trap.
9. Steam Tunnel Junction Box: Junction box shall be VDOT modified JB-1.

10. Precast Steam Tunnel: Shall be VDOT Standard BCS-DT single box culvert. Laying lengths shall be 72" with dove-tail joints. Inside dimensions shall be 6' × 6'.
11. Invert Shaping: Unless shown otherwise on the plans, all inverts shall be shaped according to VDOT Standard IS-1, or invert shaping shown on the manhole detail.
12. Sanitary Sewer Drop Manhole: A drop stack is required when the difference between invert-in and invert-out of the pipes is 2 feet or greater.

4.7.1.3 Execution

1. Installation
 - a. Manholes: The subgrade and bedding for the monolithic base for the precast manhole shall be prepared similar to that for pipe. Invert shaping is required for all sanitary sewer manholes and for storm manholes where noted. The invert channels shall be formed with concrete as shown on the VDOT Standard Details MH-1 and MH-4 and shall be smooth and semi-circular in shape, conforming to the inside of the adjacent sewer section. Changes in direction of flow shall be made with a smooth curve of as large a radius as the size of the manhole will permit. The floor of the manhole outside of the channels shall be smooth and shall slope toward the channels not less than 2 inches per foot, nor more than 4 inches per foot.
 - b. Sanitary Sewer Manhole Joints: Joints shall be a double ring of butyl rubber rope caulk to form a watertight seal. Manhole frames, covers, and hatches shall also be set on a double ring of butyl rubber rope caulk. When leveling is required manhole frames shall be set level on a full bed of mortar to the proper grade prior to the application of the butyl caulk. Under no circumstances shall manholes or other structures be left in an incomplete condition such that surface water could enter into the sewer line.
 - c. Steam Tunnel:
 - i. Reinforced Concrete Inverted "U" Tunnel: Conduit foundation slab shall be minimum 4000 psi concrete reinforced with four #4 rebar spaced equally from edges. Tunnel top shall be a minimum of 5000 psi concrete. The rebar shall be set a minimum of 1.5" above the bottom of the trenches. No portion of the concrete base cross section shall be less than 6" thick. A 1-3/4" × 5-5/8" internal drain shall be provided throughout all runs. Slab surfaces shall be

seeded straight and to proper grade and pitched uniformly to drainage points. The foundation slabs and drain shall extend through the building and manhole walls. Bedding for the foundation slab shall be shown on the plans.

A mastic sealant shall be used at all base joints. The sealant shall be three-quarters of an inch in thickness. After installation of conduit, all exterior joints shall be sealed with grout to a smooth finish with no rough spots to cut the waterproofing membrane.

After all joints are sealed with grout and smoothed, a heavy coat of underground asphalt sealing compound shall be applied to all joints. A waterproofing membrane shall be installed over the entire conduit system. The membrane shall be 30 mils neoprene lining. At all separations of the lining a 6-inch overlay shall be used and sealed with a mastic sealant to a waterproof seal. The entire conduit system shall be made waterproof.

- ii. Walkthrough Steam Tunnel: Walkthrough steam tunnel shall be precast single box culvert in accordance with VDOT Standard BCS-DT, and shall be 6' × 6' interior. Bedding shall be 6 inches of VDOT #26 stone. A double ring of butyl rubber caulk shall be used at all joints. Waterproofing shall be as stated under reinforced concrete inverted "U" tunnel.

2. Tests

- a. Manhole Vacuum Testing: Unless otherwise approved by the A/E, manholes shall be tested by the vacuum method. Manholes shall be tested after assembly and after backfilling. The Contractor is encouraged to test the manhole prior to backfilling. Stub-outs, manhole boots and pipe plugs shall be secured to prevent movement while the vacuum is drawn. Installation and operation of vacuum equipment and indicating devices shall be in accordance with equipment specifications for which performance information has been provided by the manufacturer and approved by the Health Department. A measured vacuum of 10 inches of mercury shall be established in the manhole. The time for the vacuum to drop to 9 inches of mercury shall be recorded.
- b. The Construction Field Representative (CFR) shall observe manhole testing.
- c. Acceptance standards for leakage shall be established from the elapsed time for a negative pressure change from 10 to 9 inches of

mercury. The maximum allowable leakage rate for a four-foot diameter manhole shall be in accordance with the following:

Manhole Depth	Minimum Elapsed Time for a Pressure Change of 1 inch Hg
10 feet or less	60 seconds
> 10 feet, but < 15 feet	75 seconds
> 15 feet, but < 25 feet	90 seconds

- d. For manholes 5 feet in diameter, add an additional 15 seconds and for manholes 6 feet in diameter, add an additional 30 seconds to the time requirements.
- e. If the manhole fails the test necessary repairs shall be made and the vacuum test and repairs shall be repeated until the manhole passes the test or the manhole shall be tested in accordance with the standard exfiltration test and rated accordingly.
- f. If a manhole joint mastic is completely pulled out during the vacuum test the manhole shall be disassembled and the mastic replaced.
- g. It is not necessary to test storm drainage manholes.

4.7.2 Domestic Water Utility Distribution Piping

- 1. Waterline Materials
 - a. C151 – Ductile Iron Pipe, centrifugally cast in metal molds or sand lined molds. For water or other liquids.
 - b. C900 – Polyvinyl Chloride (PVC) pressure pipe, 4" through 12" for water.
 - c. C905 – PVC water transmission pipe, 14" through 36".
- 2. Water Main: At the Contractor's option, water lines 4" and larger shall be one of the following:
 - a. Polyvinyl Chloride Pipe: All PVC pipe shall meet or exceed the following requirements:
 - i. All pipe and fitting shall be made from PVC components as defined in ASTM D1784 and AWWA C 900.
 - ii. Pipe shall have a minimum 4:1 safety factor at its recommended maximum working pressure.
 - iii. Standard laying length of pipe shall be 20 feet.
 - iv. PVC pipe shall be SDR-18, Class 150.
 - v. Joints shall be push-on type; the basis of design shall be "Ring Tite," or equivalent with rubber rings conforming to ASTM 3139 and ASTM F477.

- vi. Lubricant: Lubricant for joints shall be that supplied by the manufacturer of the pipe being used. If PVC pipe is used, the lubricant for PVC pipe shall be used at joints with valves, fittings, hydrants, or other pipe materials. With PVC pipe, no lubricant harmful to polyvinyl chloride plastic shall be used.
 - b. Ductile Iron Pipe: All ductile iron pipe (DIP) for sewer or water installation shall meet or exceed the following requirements:
 - i. Pipe shall be the diameter shown on the drawings.
 - ii. Pipe shall be Class 350 in accordance with AWWA C150.
 - iii. Pipe shall be cast in accordance with AWWA C151.
 - iv. Pipe shall be cement lined in accordance with AWWA C104.
- 3. Water Lines: Water lines 3" shall be ductile iron and shall meet the following requirements:
 - a. Pipe shall be the diameter shown on the drawings.
 - b. Pipe shall be Class 350 in accordance with AWWA C150.
 - c. Pipe shall be cast in accordance with AWWA C151.
 - d. Pipe shall be cement lined in accordance with AWWA C104.
- 4. Water lines 2" and smaller shall be CTS with brass compression fittings.
- 5. All water lines and chilled water lines shall have a #12 AWG solid copper tracer wire attached to the line. The tracer wire shall be brought into the valve box with enough slack to allow removal of the end of the wire for connection to tracing equipment.
- 6. There shall be no gripper gaskets on restraining joints.
- 7. Hot Water Supply and Return (HWS and HWR) in manholes and/or tunnels
 - a. 2 ½" and Larger:
 - i. Pipe – ASTM A53B, Type E, galvanized, electric resistance welded, schedule STD.
 - ii. Fittings – ASTM A234 Grade WPB/ANSI B16.9, Schedule STD, seamless, galvanized.
 - iii. Flanges – Class 150, galvanized.
 - b. Special Considerations:
 - i. After wire brushing the final pass and while the pipe is hot, apply zinc spray. The basis of design for zinc spray shall be ThermaCote Galvanize.
 - ii. Provide chlorine for cleaning piping and flush per local regulations. Test prior to putting in service per local regulations.

4.7.3 Water Valves

1. Valve Boxes: Adjustable cast iron boxes of suitable diameter, length, and design shall be furnished and installed for all buried valves excluding post-indicator valves. Boxes shall be three-piece screw type, with #6 round base (#8 for 8" valves). Valve boxes shall be in accordance with Standard Detail VB-1.
2. Valve installation:
 - a. Valve stems shall be oriented for accessibility.
 - b. Valves shall be installed so no forces are transmitted to the valve through the piping or valve boxes.
 - c. Flushing: All valves and appurtenances shall be flushed clear of all foreign material after installation.
 - d. Field test all valves and appurtenances for proper operation, proper adjustments, binding, scrapings, and other defects. Check all valves and boxes for high quality.
 - e. A valve box shall be provided for every valve. The valve box shall not transmit shock or stress to the valve and shall be centered and plumb over the wrench nut of the valve, with the box cover flush with the surface of the finished grade or as directed by the engineer.
 - f. Water pipe lines shall be protected against joint pulling or thrust damage by suitable mechanical joint restraint devices at all joints, fittings, and all other critical points. Mechanical joint restraint shall be incorporated in the design of the follower gland and shall include a restraining mechanism which, when actuated, imparts multiple wedging action against the pipe, increasing its resistance as the pressure increased. Flexibility of the joint shall be maintained after the burial. Glands shall be manufactured of ductile iron conforming to ASTM A536-80. Restraining devices shall be of ductile iron heat treated to a minimum hardness of 370 BHN. Dimensions of the gland shall be such that it can be used with the standardized mechanical joint bell and tee-head bolts conforming to ANSI/AWWA A21.11/C111 and ANSI/AWWA A21.53/C153 of latest revision. Twist-off nuts, sized same as tee-head bolts shall be used to insure proper actuating of restraining devices. The mechanical joint restraint shall have a working pressure of at least 235 psi with a minimum safety factor of 2:1. The basis of design for the grip ring shall be Romac and Romac style 611 for bell joints.

4.7.3.1 Domestic Water Valves

Gate Valves: For domestic water, valves shall be cast iron body, resilient seated with reinforced rubber seat ring or permanently bonded disc, and machined seating surface, brass or bronze non-rising stems, and shall comply with AWWA C509. All valves shall have right-hand threads.

A post indicator valve shall be installed on all buildings that are fully sprinkled. The post indicator valve shall be a resilient seal valve (N.R.S.), open left. The basis of design for the post indicator shall be Mueller or approved equal.

4.7.3.2 Chilled Water Valves

Gate Valves: For chilled water lines, valves shall be cast iron body, resilient seated with reinforced rubber seat ring or permanently bonded disc, and machined seating surface, and brass or bronze non-rising stems. All valves shall have right-hand threads.

4.7.4 Water Utility Metering

1. Water meters up to 2" shall be:
 - a. Zenner (performance) Multi-Jet type Magnetic Drive cold water meter Nitro1 with encoder type Register with Itron quick connect, or
 - b. Badger Meter Recordall Disc Series positive displacement meter with HR-E High Resolution Encoder, or
 - c. Mueller Systems 500 Series Magnetic Drive Positive Displacement Disc meter with Mueller Systems ME-8 encoder.
2. Water meters 2" and larger shall be:
 - a. Zenner (performance) Bronze Turbine Meter with encoder type register with Itron quick connect, or
 - b. Badger Meter Recordall Turbo Series direct coupled turbine meter with HR-E High Resolution Encoder, or
 - c. Mueller Systems Hersey HbMAG electromagnetic flow meter with integral register and an Itron 100W Endpoint (ERT) module with an Itron in-line connector cable.
3. Encoder types shall be specific to the water meter selected:
 - a. Zenner (performance) meters shall have an Itron 100W Encoder with an inline connector, part #ERW-0771-202, Utility ID#181 for Virginia Tech.
 - b. Badger meters shall have a Badger HR-E High Resolution Encoder with an in-line connector.

- c. Mueller Systems 500 Series meters shall have a Mueller Encoder Eight (ME-8) with an in-line connector. Mueller Systems Hersey HbMAG meters shall have an Itron 100W Endpoint (ERT) module with an Itron in-line connector cable.

4.7.5 Fire Hydrant

The basis of design for the fire hydrant shall be Mueller Super Centurion 4½" Pumper connection and 2-2½" hose nozzles, or equal approved by the University.

4.7.6 Field Quality Control

4.7.6.1 Testing Water Lines Excluding the Fire Line

Test pressures shall be 150 psi unless otherwise noted. Testing shall begin on the first valved section of line within ten days after its completion. The pressure and leakage tests shall be conducted concurrently for a duration of two hours.

Leakage shall be defined as the quantity of water that must be supplied into the valved pipe section to maintain pressure within 5 psi of the specified test pressure. The allowable leakage shall not exceed the values given in table labeled Allowable Leakage per 1,000 Feet of Pipeline.

The valved section of the pipe under consideration shall be slowly filled with water and brought to the specified pressure by means of a pump. Before supplying the specified test pressure, all air shall be expelled from the pipe. The Contractor shall supply taps for expelling air. Testing shall not begin until at least seven days after the last concrete anchor has been poured on the section of line being tested (if high early concrete is used, two days). The CFR shall observe all leakage tests.

If the pipe fails to meet test requirements, all leaks shall be repaired and defective pipe repaired or replaced at the Contractor's expense. The test shall be repeated until satisfactory results are obtained. The Contractor shall be charged for all retests at the normal rates for inspection services.

Allowable Leakage per 1,000 Feet (305 m) of Pipeline (gph)												
Average Test Pressure	Pipe Size											
psi	2	3	4	6	8	10	12	14	16	18	20	24
200	0.21	0.32	0.43	0.64	0.85	1.06	1.28	1.48	1.70	1.91	2.12	2.55
175	0.20	0.30	0.40	0.59	0.80	0.99	1.19	1.39	1.59	1.79	1.98	2.38
150	0.00	0.00	0.00	0.00	0.00	0.00	0.00	0.00	0.00	0.00	0.00	0.00

If the pipeline under test contains sections of various diameters, the allowable leakage will be the sum of the computed leakage for each size.

4.7.6.2 Testing Fire Line

1. Flushing of Piping: Underground mains and lead-in connections to system risers shall be flushed thoroughly before connection is made to system piping in order to remove foreign materials which may have entered the underground main during the course of the installation or which may have been present in existing piping. The minimum rate of flow shall not be less than the water demand rate of the system, which is determined by the system design, or not less than that necessary to provide a velocity of 10 feet per second (3 m/sec.), whichever is greater. For all systems, the flushing operations shall be continued for a sufficient time to ensure thorough cleaning. When planning the flushing operations, consideration shall be given to disposal of the water issuing from the test outlets.
2. Hydrostatic Test Requirements: All new private fire service mains shall be tested hydrostatically at not less than 200 psi (13.8 bar) pressure for two hours. The amount of leakage in piping shall be measured at the specified test pressure by pumping from a calibrated container. For new pipe, there shall be no allowable leakage at the joints.

The CFR shall observe all leakage tests and flushing operations. If the pipe fails to meet test requirements, all leaks shall be repaired and defective pipe repaired or replaced at the Contractor's expense. The test shall be repeated until satisfactory results are obtained. The Contractor shall be charged for all retests at the normal rates for inspection services.

4.7.7 Sanitary Sewer Piping

At the Contractor's option, sewer pipe shall be one of the following materials, unless otherwise shown on the plans:

1. Polyvinyl Chloride Pipe: All PVC shall be PVC SDR 35 or PVC Schedule 40.
2. Ductile Iron Pipe: All DIP shall meet or exceed the requirements of AWWA C104, C150, and C151.

For procedures for testing non-pressure plastic pipe sewer lines, the Contractor shall follow the latest version or revision of ASTM F 1417-11a(2019).

4.7.8 Chilled Water Distribution

4.7.8.1 Underground Piping

1. Pipe material shall be PVC Pressure Pipe AWWA C900/C905, DR14 rated for 305 psi working pressure for sizes 4" through 12", DR18 rated for 235 psi working pressure for sizes 14" through 30", and DR21 rated for 200 psi for 36".
2. The system design maximum pressure shall be 150 psi and the hydro test pressure shall be 200 psi.
3. The basis of design for pipe joints shall be push joint with mechanical restraints equal to EBAA Series 1900 or Series 2800. Restraints shall be ASTM A536 ductile iron and designed for use with AWWA C900/C905 piping. Restraints shall be coated with a corrosion protective coating for direct burial use. Pressure rating of the restraint and fasteners shall be equal to or greater than that of the pressure rating of the piping system. All bolts and nuts shall be low alloy steel with corrosion protective coating.
4. Pipe fittings shall be ductile iron mechanical joint type manufactured in accordance with the latest revisions of AWWA C110/A21.10 and AWWA C111/A21.11 and rated for 250 psi working pressure. AWWA C153 compact fittings are not allowed.
 - a. Pipe fittings shall be designed to provide positive restraint against end-wise separation due to thrust through the use of mechanical restraints. The basis of design for pipe fittings shall be EBAA Iron Series 2000PV or equal. The pressure rating shall be a minimum of 250 psi. All restraints shall be provided with a factory-applied corrosion protective coating.
 - b. All bolts and nuts shall be low alloy steel with corrosion protective coating.
 - c. All gaskets shall be SBR.
 - d. Piping connection at point of entry to structures shall be made with a factory flange on the underground piping and not a set screw type (uni-flange) or gripping wedge type (mega-flange) flange or flange adapter.

4.7.8.2 Direct Buried Butterfly Valves

1. Valves shall conform to latest revision of AWWA C504. Valves shall be tight closing and rubber-seated. Valves shall be bubble-tight at the rated pressure in either direction, and shall be suitable for throttling service

and operation after long periods of inactivity. Valves shall be rated for 200 psi non-shock working pressure-minimum. Valves shall be designed for direct buried application.

2. Valves shall be cast iron body ASTM A126B, Class B, restrained mechanical joint (AWWA C151/ANSI 21.11) or flanged (ANSI B16.1) ends. Valves shall be furnished complete with joint accessories (bolts, nuts, gaskets and glands).
3. The resilient seat shall be capable of mechanical adjustment in the field and field replacement.
4. Valves shall be hydrostatically and leak tested in accordance with AWWA C504.
5. Valves shall be complete with grease-packed buried service gear operator and shaft extensions with centering disk located on shaft to within one foot of finished grade and soil pipe.

4.7.9 Steam Distribution Tunnel

4.7.9.1 Pre-Cast Materials

1. Concrete shall conform to ASTM C478 and as follows:
 - a. Compressive Strength: 5000 psi minimum at 28 days.
 - b. Air Content: 4% minimum.
 - c. Cementitious Materials: Minimum of 564 lb./cu. yd.
 - d. Course Aggregates: ASTM C33. Sound, Crushed, Angular Granitic Stone only. Smooth or rounded stone shall not be used.
 - e. Fine Aggregates: ASTM C33. Free from organic impurities.
 - f. Chemical Admixtures: ASTM C494. Calcium chloride or admixtures containing calcium chloride shall not be used.
 - g. Air Entraining Admixtures: ASTM C260.
2. Reinforcing steel shall be ASTM A615 grade 60 deformed bar, ASTM A82 wire, or ASTM A185 welded wire fabric.
3. All reinforcing steel used in underground steam system structures including but not limited to manholes, pre-cast tunnel covers, tunnel slab, etc., shall be galvanized.
4. Lift loops shall be ASTM A416 steel strand. Lifting loops made from deformed bars shall not be allowed.

4.7.9.2 Pre-Cast Components

1. Lifting inserts, holes, and devices shall comply with OSHA Standard 1926.704. Lift holes and inserts shall be sized for precision fit with lift

devices and shall not penetrate through structure wall. Lifting devices shall be provided by Precast Manufacturer.

2. Joints shall be sealed internally between tongue and groove and additionally around external perimeter of the joint.
3. Components shall be designed in accordance with ACI, ASTM C890.
4. Rectangular subgrade components shall be designed and manufactured in conformance with ASTM C913.

4.7.9.3 Waterproofing

1. Waterproofing for this section shall apply to all underground structures, precast and poured-in-place.
2. Provide a multilayer waterproofing sheet membrane system rated for buried service.
3. The waterproofing membrane shall have the following minimum properties:

Puncture Resistance	169 lb., FTMS 101B
Tensile Strength	4000 psi
Elongation	700%
Resistance to Hydrostatic Head	150 ft - zero leakage
Coefficient of Permeability	2.7×10^{-13} cm ³ /cm ² /sec
Packaging	4' × 24' rolls
Thickness	170 - 200 mils

4. The waterproofing membrane shall be protected from backfill by a layer of non-woven polypropylene or as recommended by the membrane manufacturer. Unless recommended otherwise by the membrane manufacturer, the protective layer shall have an approximate weight of one-half pound per square yard.

4.7.10 Steam (LPS and HPS), Condensate, and Pumped Condensate Valves

1. Manufacturers: Kitz, Powell, Crane, Edwards, Milwaukee, Williams, Adams, Zwick, Yarway, or approved other.
2. Gate Valves
 - a. 2" and Smaller – steel body, rising stem, threaded ends, solid wedge, stainless steel trim, bolted bonnet, OS&Y malleable iron hand-wheel, minimum Class 600 Non-rising stem valves are not acceptable.
 - b. 2½" and Larger – steel body, rising stem, flanged ends, OS&Y, bolted bonnet, 13% CR steel wedge, hard-faced steel or stellite seat, stainless

- steel trim, stainless steel stem, malleable or ductile iron hand-wheel, Class 300, designed in accordance with ASME B16.34.
- c. Provide all valves with removable insulating blankets.
 - d. Valves and gaskets shall use no components containing asbestos.
3. Triple Offset Valves (High Pressure Steam Service)
- a. Triple offset valves are only to be used where gate valve use would otherwise result in excessive sizing of manholes or access. Unless there is a significant cost savings.
 - b. 12" and Larger – Class 300, quarter turn, metal to metal seated, incorporating “inclined conical” geometry creating a torque seating operation. Valves shall provide bi-directional bubble tight shut-off and be designed in accordance with ANSI/ASME B16.34 and B31.3.
 - c. Valve bodies shall be double flanged, cast steel, able to withstand induced pipe loads without distortion and effect on the movement of the disc. Valves shall be complete with blow out proof stem.
 - d. Valve disc shall be 316 stainless steel. Disc attachment to the shaft shall be by means of parallel keys. Disk to shaft attachment by use of pins is not allowed.
 - e. The valve shaft shall provide adequate strength to operate the valve at full rated design conditions. Shaft shall be one piece. A thrust bearing shall be provided to absorb thrust in both directions and provide blowout protection. The shaft diameter shall be reduced at the actuator connection so as to put the weakest point outside the valve above the packing.
 - f. The seal ring shall consist of laminations of 316 SS and graphite. The seal ring shall be secured by means of a retainer to insure no movement or flexing. Retainer bolting on internal rotating parts is not allowed. No leakage behind the seat ring is allowed.
 - g. The packing gland shall be provided with a minimum of four studs for precision adjustment and compression of the packing. Packing shall consist of a minimum of five packing rings suited for the pressure and temperature rating of the valve.
 - h. Valves will incorporate solid metal, press fit shaft bearings which are sealed from the ingress of particulates or contaminants. Sufficient differential hardness between the shaft and bearing surfaces shall be provided to insure smooth, non-galling rotation.
 - i. Valve actuators shall be provided with self-locking gears. The actuator mounting bracket shall be rigidly pinned to the body and centered by machined register between bracket and body.

- j. Valves shall be tested in accordance with ASME B16.34-1996 and API598-1996. Valves shall be factory tested for seat leakage from both sides of the disc. Provide test certifications with each valve.
 - k. Valve machined surfaces shall be protected with anticorrosive coatings prior to shipment.
 - l. All steam and condensate valves shall be provided with removable insulating blankets.
4. Ball Valves (Condensate Only)
- a. 6" and Smaller: ASTM A216 WCB steel body, flanged, stainless steel ball, full port, PTFE seat, stainless steel stem, two-piece construction, ANSI class 150, Apollo 88A-200 series, Milwaukee F20CS150 series, Nibco F-515-CS-F-66-FS series or Kitz 150SCTBZM (C) or approved equal.
 - b. 8" and Larger: gate valves as specified above, provide Class 150 for condensate valves in lieu of Class 300 for steam.
 - c. Provide rotary hand wheel operators with gear actuators and with adjustable position stop and position indicators. Size hand wheel operators with no higher than 40 lb. rim pull at full valve pressure rating.
 - d. Provide valve neck extensions with sufficient length to allow for insulation where insulation blanket.
 - e. All steam and condensate valves shall be provided with removable insulating blankets.
5. Check Valves
- a. 2½" and Smaller: A 105 forged carbon steel body, horizontal globe, threaded ends, series 400 stainless steel renewable disc and seat, ANSI Class 600.
 - b. Provide check valves at steam condensate lines at outlet of all traps. Install check valve between trap and gate valve.
6. Globe Valves
- a. 2" cast steel, flanged, union bonnet, stainless steel plug disc and seat rings, malleable iron hand-wheel, Class 300, conforming to ASME B16.34, Powell Fig. 3031 or equal.
 - b. Install 2" globe valves in bypass lines around each main steam valve. Position valve handle accessible and locate valve in bypass such that it will not interfere with operation or maintenance of the main steam valve.
7. Drain Valves
- a. Gate valve for steam or ball valves for condensate as specified above. Provide drain valves on each side of steam valves. Provide drain valve on condensate on each side of take offs from main. Drain valves shall be provided with short threaded nipple and cap.

- b. Provide drain valves at all low points of piping systems for complete drainage of systems.

4.7.11 Steam Pipe and Fittings

4.7.11.1 General

1. Description
 - a. Use only new material, free of defects, rust and scale, and guarantee for services intended.
 - b. Use material meeting the latest revision of ASTM specifications as listed in this specification.
 - c. Follow local codes if they require other types of pipe or joints.
 - d. Use only long radius elbows having a centerline radius of 1.5 pipe diameters unless otherwise indicated.
 - e. Manufacturer, pressure class, size and heat code of each fitting and flange shall be permanently identified on its body in accordance with MSS SP-25.
 - f. Where size for a pipe segment is not indicated, the pipe segment size shall be equal to the largest pipe segment to which it is connected. Transition to smaller size shall occur on the side of fitting where smaller size is indicated.
 - g. Unless otherwise indicated, fittings and accessories connected to pipe shall be of the same material as the pipe.
 - h. Unless otherwise indicated, construct piping for highest pressures and temperatures in respective system in accordance with the latest revision of the applicable sections of the ASME Code for Pressure Piping, ANSI/ASME B31.1, including the following: B31.1 Power Piping (All Piping).
2. Pipe welding:
 - a. Welding shall be done using only the following processes:
 - i. Shielded Metal Arc Welding (SMAW)
 - ii. Gas Tungsten Arc Welding (GTAW)
 - iii. Gas Metal Arc Welding (GMAW)
 - iv. Flux Cored Arc Welding (FCAW)
 - v. Submerged Arc Welding (SAW)
 - b. Unless otherwise stated, fabrication, installation, inspection, examination and testing shall be in accordance with ASME B31.1, as applicable.
 - c. Backing rings (chill rings) or consumable inserts are not allowed.

3. Weld Examination Procedures:
 - a. 100% of the steam and condensate field welds on underground piping installed under this contract will be inspected and tested by non-destructive examination. Weld inspection will be paid for by the University with project funds using a third party testing agency.
 - b. Approximately 10% of the welds on steam and condensate pipes in manholes and tunnels installed under this contract will be inspected and tested by non-destructive examination. Weld inspections will be paid for by the University with project funds using a third party testing agency. Coordinate weld inspections with the VT PM.
 - c. Any failure of a weld will require re-inspection of the failed weld at the Contractor's expense. The piping vendor shall test each factory weld and provide weld reports during construction when pipe is delivered to the Contractor.
 - d. All tests shall be performed by an AWS-CWI (American Welding Society Certified Welding Inspector) selected and contracted by the University.
 - e. All steam and condensate butt welds to be tested as specified above, shall be tested by means of radiography or ultrasound. The criterion for pass/fail of this test will be as defined in the latest edition of the ASME B31.1 Power Piping code.
 - f. 10% of steam and condensate socket weld connections shall be tested by means of dye penetrate, magnetic particle analysis, radiography, or ultrasound by University's testing agency and paid for by the University with project funds. The criterion for pass/fail of this test will be as defined in the latest edition of the ASME B31.1 Power Piping code.
 - g. The firm providing the testing services shall determine prior to pipe joint fit up if the area of radiography exposure is:
 - i. Completely inside the construction fence or tunnel.
 - ii. Beyond the construction fence and not impacting adjacent buildings.
 - iii. Beyond the construction fence and impacting adjacent buildings.
 - iv. If the area of radiography exposure is determined to impact areas outside of the construction fence, contact the VT PM for coordination of signage, barricades and monitoring.
 - h. In the rare occurrence where radiography cannot be used to test a weld due to site restrictions the weld may be visually inspected by an

AWS-certified welding inspector provided that all the following conditions are met.

- i. The VT PM and A/E must agree that a radiographic test cannot be reasonably achieved.
 - ii. The pipe joint fit up must be inspected prior to welding by an AWS-CWI.
 - iii. All welding passes must be inspected by an AWS-CWI including the root pass, hot pass, and all fill and cover passes.
 - iv. If any of these steps are bypassed, and radiography cannot be utilized to verify the joint integrity, then the joint will be rejected outright and it will be replaced at the Contractor's expense. The replacement joint will be subject to the same testing requirements.
 - v. All initial testing will be funded by the University through the project funds.
 - vi. All repairs and re-examination of repaired welds will be at the Contractor's expense.
4. Welder Qualifications:
- a. Each welder and welding operator must qualify by passing the required procedure test before performing any project welds. Submit copy of Manufacturer's Record of Welder or Welding Operator Qualification Tests as required by Section IX of ASME Boiler and Pressure Vessel Code for all welding procedures to be performed by the welding operator.
 - b. Qualification tests for each welder shall be the responsibility of the Contractor. Welder qualifications must be current. If qualification test is more than 6 months old, provide record of welding continuity for each welder.
 - c. Record of welding continuity is intended to show that welder has performed welding at least every 6 months since the date that welder qualification test was passed for the submitted welding procedure specification.
 - d. Record of welding continuity shall include, at a minimum, the following:
 - i. Welder's employer name and address
 - ii. Date Welder Qualification Test was passed
 - iii. Dates indicating welding continuity
 - e. Welders shall be qualified as required by B31.1, as applicable. In addition, there shall be an independent witness of welder tests. That

- witness shall be a representative of an independent testing laboratory, or the UBO's/Engineer's Inspector, or a consultant approved by American Welding Society Certified Welding Inspector.
- f. Test segment shall be 2" nominal pipe size with wall thickness within range of WPS for each pipe material specified in this Section. Test position shall be arranged in "6G position." In addition to above test requirement, welding operator shall perform test on coupons which qualify for all piping sizes and wall thickness used on this project.
 - g. Engineer reserves the right to test work of any welder employed on project, at Contractor's expense. If work of the welder is found to be unsatisfactory, the welder shall be prevented from doing further welding on project.
5. Weld Record:
For all welding within the scope of ASME B31.1 Power Piping, submit to Engineer for approval and administrative procedure for recording, locating, monitoring, and maintaining the quality of all welds to be performed on the project. This quality control document record shall include but not be limited to: drawings and schedules identifying location of each weld by individual number, identification of welder who performed each weld by individual welder's name, stamp number, date, and WPS used.
6. Pipe Certification
- a. Certification is required for all pipe within the scope of ANSI/ASME B31.1. Submit certification papers, as outlined below, within 30 days of delivery of pipe to project site.
 - b. Type E or S Pipe: Furnish manufacturer's mill certificates (material test report) including dimensions, heat numbers, chemical analysis and tensile test results for pipe shipped to project site.

4.7.11.2 Products

- 1. High Pressure Steam (HPS) in Manholes and/or tunnels.
 - a. 2" and Smaller:
 - i. Pipe – ASTM A53B or ASTM A106B, Type S, black steel, seamless, schedule 80.
 - ii. Fittings – ASTM A105/ANSI B16.11, 3000 lb. forged steel, socket weld.
 - iii. Flanges – Class 300, refer to unions and flanges in this section.

- b. 2½" and Larger:
 - i. Pipe – ASTM A53B or ASTM A106B, Grade B, Type E or S, black steel, ERW or seamless, schedule 40.
 - ii. Fittings – ASTM A234 Grade WPB/ANSI B16.9, schedule standard, seamless, carbon steel butt weld fittings.
 - iii. Flanges – Class 300, refer to unions and flanges in this section.
- 2. Condensate (CPD), High Pressure Condensate (HPC), and High Pressure Return (HPR) (in manholes and/or tunnels)
 - a. 2" and Smaller:
 - i. Pipe – ASTM A53B or ASTM A106B, Type S, black steel, seamless, schedule 80.
 - ii. Fittings – ASTM A105/ANSI B16.11, Grade 2, 3000 lb. forged steel, socket weld.
 - b. 2½" and Larger:
 - i. Pipe – ASTM A53B or ASTM A106B, Grade B, Type E or S, black steel, ERW or seamless, schedule 80. Extra heavy is not allowed.
 - ii. Fittings – ASTM A234 Grade WPB/ANSI B16.9, schedule 80, seamless, carbon steel butt weld fittings. Standard weight or extra heavy is not allowed.
 - iii. Flanges – Class 150, refer to unions and flanges in this section.
- 3. HPS, CPD, and HPR (Direct-Buried Underground)

Direct-Bury Underground steam pipe shall only be used for laterals from the steam main to serve a single building. Direct-Bury steam pipe shall not be used for steam mains. Direct Bury Underground steam pipe shall not be used in any circumstance when crossing an active roadway.

 - a. General:
 - i. All underground steam and condensate shall be engineered drainable, dryable type. Contractor fabricated piping and fittings are not allowed. No metal components shall be exposed to earth.
 - ii. The high pressure piping design shall be based on 125 psig superheated steam at 600 °F. The condensate piping line shall be based on 125 psig at 250 °F.
 - iii. All straight sections, fittings, anchors and other accessories shall be factory prefabricated to job dimensions, and designed to minimize the number of field welds. The design shall be computer analyzed by the piping system manufacturer to determine stresses and movements of the service pipe and to ensure that the system design is in strict conformance with

ANSI B31.1 latest edition, and stamped by a registered professional engineer licensed in the state of Virginia. The analysis shall include piping and structures inside the manholes.

- iv. For projects with Direct-Buried Underground piping the piping manufacturer shall provide on-site technical assistance during installation of the piping for the minimum days stated below. The factory representative shall be a factory trained technician to witness requirements outlined in the installation portion of this standard.
 - 1. Projects with less than 100 linear feet of piping - minimum of 5 days
 - 2. Project with 100 linear feet or more of piping - minimum of 15 days
 - v. All underground piping shall have a #12 AWG solid copper tracer wire attached to pipes and extended into vaults, tunnels, or manholes.
- b. Pipe Support Guides:
- i. Piping shall be spaced and supported at a maximum of 10 foot intervals in conduit by insulating support-guides and to permit pipe to expand and contract freely without stress or wear on pipe or insulation as well as provide for drainage and free air circulation.
 - ii. All sleeve type expansion joints shall employ piping guides to insure proper pipe alignment.
- c. Expansion loops, moment guided, ells and tees.
- i. Prefabricated ells, loops and tees to be provided shall consist of pipe, insulation, and conduit conforming to the same pipe and welding specifications as specified before herein for straight runs. Tees, anchors, elbows and other fittings shall be factory connected and prefabricated to straight sections whenever shipping requirements permit. All fittings shall be designed with adequate space to account for pipe expansion.
 - ii. Expansion loops to be of proper design in accordance with stress limits indicated by ASME Code for pressure piping, District Heating Section. Install loop piping in conduit suitably oversized to accommodate the calculated pipe expansion without damaging the insulation.

- iii. The piping system may be designed with both expansion loops and expansion joints. The piping system shall be designed to accommodate each type of expansion system by including moment guides as required for the piping system to function properly in conjunction with expansion joints.
 - iv. Cold springing or pre-stressing piping as a means for control of expansion in any portion of the steam system is not allowed.
- d. Anchors:
- i. All anchors on the steam line shall be designed to thermally isolate the carrier pipe from the anchor plate based on design conditions, to insure interface temperature on anchor plate to 200 °F. All steel anchor plates shall be isolated from the soil with a double layer of high ratio shrink wrap capable of withstanding 200 °F temperature. The pre-engineered pipe manufacture shall submit design engineering calculations with submittal on temperature interface. All anchor plate thickness shall be designed to accommodate the thermal expansion forces based on the design conditions. The new piping system may be designed with a combination of both expansion loops and expansion joints. Each anchor shall be designed to withstand the forces imposed by either means of expansion control.
 - ii. Concrete block to be cast over plate and conduit and to be large enough for firm anchorage into undisturbed trench sidewalls and/or bottom. Concrete block to be at least 36" in length and extend minimum of 12" beyond entire anchor plate. The piping vendor shall provide detailed instructions to Contractor for oversized anchors due to expansion joints. The Contractor shall provide oversized anchors as detailed by the piping vendor.
- e. End Seals and Gland Seals:
- i. Terminal ends of conduits inside manholes shall be equipped with end seals consisting of steel bulk head plate welded to pipe and conduit. Where there is no anchor within 5'-0" of terminal end, conduits shall be equipped with gland seals to end of conduit. End seals or gland seals to be equipped with drain and vent consisting of packed stuffing box and gland follower mounted on steel plate welded to end of conduit. Ends seals or gland seals to be equipped with drain and vent

- openings located diametrically opposite on vertical centerline of mounting plane and to be shipped to job site with plugs in place. Terminate conduits 4" beyond inside face of manhole or building walls to protect any exposed piping insulation from damp-wall condensation.
- ii. All end and gland seals shall be reinforced with 24" long galvanized steel sleeve at the sealing surface to prevent compression of the outer jacket and insulation from modular wall sealing devices. The protection sleeve shall be minimum 6 gauge thickness and shall be outside of the HDPE jacket. Where the galvanized steel sleeve stops on the outside of the manhole, the sleeve shall be shrink wrapped to the HDPE jacket and sealed water tight.
 - iii. All end seals and gland seals inside manholes, shall be thermally isolated based on design conditions to insure that the outer steel conduit is maintained below 200 °F. The pre-insulated pipe manufacturer shall submit engineering design calculations on the temperature interface at the terminations.
- f. Field Joints:
All field joints shall consist of field installed mineral wool insulation banded with stainless steel bands on the carrier pipe, field applied 10 gauge connector sleeve on the inner conduit, field applied foam insulation, polyethylene heat shrink wrap and split HDPE jacket at a minimum. All field joint materials and methods shall be provided by and approved by the piping manufacturer.
- g. Service Pipe (Steam Carrier Pipe):
Internal piping for all pipe sizes shall be ASTM A106B, Schedule Standard, Type S, seamless, carbon steel. All joints shall be butt-welded. Straight sections shall be supplied in 40-foot or random length with 6" of piping exposed at each end for field joint fabrication where possible. Fittings shall be ASTM A234 Grade WPB/ANSI B16.9, Schedule Standard, seamless, carbon steel butt weld fittings.
- h. Service Pipe (Condensate Carrier Pipe):
Internal piping for all pipe sizes shall be ASTM A106B, schedule 80, Type S, seamless, carbon steel. All joints shall be butt-welded. Straight sections shall be supplied in 40-foot sections or random length with 6" of piping exposed at each end for field joint fabrication where possible. Fittings shall be ASTM A234 Grade WPB/ANSI B16.9, Schedule 80, seamless, carbon steel butt weld fittings.

- i. Service Pipe Insulation:
Insulation shall be mineral wool insulation fabricated in half or V-Groove insulation sections. The insulation shall be secured to the pipe by stainless steel bands. Insulation thickness shall be as specified herein with a thermal conductivity of not more than 0.33 at 200 °F mean temperature. The insulation shall be installed such that joints are staggered preventing a continuous joint between the carrier pipe and the inner conduit.
 - j. Inner Conduit:
10 gauge for conduits 26" and smaller. 6 gauge for conduits above 26". All conduit shall be either electric resistance welded pipe conforming to ASTM A-135 or electric fusion welded pipe conforming to ASTM A-139. Conduit shall be finished in prime coat finish. Where field welds and connections are made, Contractor shall field install prime coat finish.
 - k. Inner Conduit Insulation and Outer Jacket:
 - i. Conduit insulation shall be factory-applied polyurethane foam, having density of 2.0 to 3.0 pounds per cubic foot for all straight lengths and fittings. The insulation thickness shall be 1" minimum. The urethane foam shall meet ASTM C591 with the following minimum characteristic K factor equal to 0.14, density of 2 pcf and a closed cell content of 90% to 95%.
 - ii. The outer jacket shall be HDPE with a minimum wall thickness of 150 mils.
 - l. System Description:
 - i. The underground conduit system shall consist of the following at a minimum:

Carrier Pipe	Insulation (Mineral Wool)	Nominal Outer Conduit
12" HPS	4.5"	26"
8" CPD	1.5"	14"
1" HPR	1.0"	6"
 - ii. All piping inner conduit shall be insulated with 0.75" polyurethane foam insulation with HDPE outer jacket as specified above.
 - m. Manufacturer: Ravanco model Insul-800, Thermacor model Duo-Therm 505, or Perma Pipe model Multi-Therm 500.
4. Unions and Flanges
- a. Unions: 2" and Smaller: Forged steel, ASTM A105 Grade 2, ASME B16.11, socket weld, 3000 lb. WOG with steel to steel seats.

- b. Flanges:
 - i. 2" and larger: ASTM A105, ANSI B16.5, hot forged steel, welding neck pattern. Slip-on pattern are not allowed. Bore dimension of welding neck flange shall match inside diameter of connected pipe.
 - ii. Use raised face flanges for mating with other raised face flanges with self-centering flat ring gaskets. Use flat face for mating other flat face flanges with full face gaskets.
 - iii. Flange pressure class indicated in respective piping service is minimum required. Mating flange pressure class shall match pressure class of device connected to such as valves and piping specialties.
- c. Flange Gaskets:
 - i. Gasket material to be asbestos free and suitable for pressure temperatures and fluid of piping system. Non-metallic gaskets shall be in accordance with ANSI/ASME B16.21 and ASTM F104. Unless otherwise indicated or recommended by manufacturer, gaskets shall be with 1/16" thick.
 - ii. Service Temperature (250 °F thru 800 °F) – Basis of design is Flexitallic Style CG, Flexible graphite filler, 304 SS winding, carbon steel centering ring, 0.175" thickness. Acceptable manufacturers are Flexitallic, Garlock, and Lamas.
- d. Bolting:
 - i. Bolts, bolt studs, nuts and washers shall have zinc plated finish. All bolts, bolt studs, nuts and washers in contact with soil shall be stainless steel.
 - ii. Thread shall be in accordance with ANSI/ASME B1.1, Class 2A tolerance for external threads and Class 2B tolerance for internal threads. Threads shall be coarse- thread series except that alloy steel bolting 1½" and larger in diameter shall be 8 pitch thread series.
 - iii. Threaded rods are not allowed as fastening elements.
 - iv. For all service temperatures, use alloy steel bolts or stud bolts conforming to ASTM A193, Grade B7 or B16, with nuts conforming to ASTM A194, Grade 2H.
 - v. No stainless steel bolts to be used for above ground steam applications.

4.7.11.3 Execution

1. General
 - a. Remove foreign materials before erection. Ream ends of piping to remove burrs.
 - b. Install piping parallel to existing tunnel or new manhole walls and at such locations as to not obstruct access or egress. Install piping to allow adequate service space for equipment and piping specialties. Install vertical piping plumb. Where interferences develop in field, offset or reroute piping as required to clear such interferences. In all cases, consult drawings for exact location of ladders, or access openings or other details before installing piping.
 - c. Provide anchors and expansion loops so that piping may expand and contract without damage to itself, equipment or other structures.
 - d. Mitered elbows, welded branch connections, notched tees and “orange peel” reducers are not acceptable. Unless specifically indicated, reducing flanges and reducing bushings are not acceptable.
 - e. Unless otherwise indicated, use fittings as specified in DCSM section 4.7.11.2 for elbows, tees, reducers, etc.
 - f. Basis of design for fittings shall be “Weldolets” and “Sockolets” (as appropriate for outlet size). “Weldolets” with outlet size 2½ to 4 inches and “Sockolets” with outlet size 2 inches and smaller may be used for branch takeoff up to one-half diameter of main. Manufactured tees shall be used where a takeoff is greater than 6 inches. Use “Sockolets” where socket weld fittings are specified. Materials of “Weldolets” and “Sockolets” shall match material of piping.
 - g. Install drains throughout systems to permit complete drainage of entire system. This includes, but is not limited to, all low points, bases of all risers and at each branch take-off.
 - h. Install all valves and piping specialties, including items furnished by others, as specified and/or detailed.
 - i. For piping within the scope of ANSI/ASME B31.1 Power Piping, transfer piping material specification and “Heat Number” to each segment of pipe prior to cutting.
2. Welded Pipe Joints:
 - a. Inspect pipe and pipe fittings for roundness before they are fit-up or set in place.

- b. Properly clean and prepare pipe base material before fit-up. Verify joint land and bevel.
 - c. Preheat pipe base material as required by the welding procedure specification. Temperature of pipe material must be a minimum of 60 °F before welding.
 - d. Properly align and adjust joint as required by welding procedure and thickness of material. Verify tolerances after tacking sequencing.
 - e. Use weld material diameter as procedurally required for type and thickness of work being done.
 - f. Properly store all welding materials.
 - g. Clean all tacks before welding out. Remove all slag after each pass by grinding to avoid slag inclusion.
 - h. Weld reinforcement shall be in accordance with Chapter V of ANSI/ASME B31.1.
 - i. Brush each weld free of rust and paint with rust resistant product that matches piping surface color.
 - j. For piping within the scope of ANSI/ASME B31.1, each weld shall be permanently marked by welder performing the weld. Each welder shall sign and date the field welding log record for all welds performed by the welder as indicated in DCSM section 4.7.11.1.
 - k. No chill rings allowed.
3. Flanged Joints:
- a. Clean flange surfaces and align flange surfaces parallel.
 - b. Gaskets shall fit concentrically without modification or centering so compression is equally distributed over entire gasket surface.
 - c. Lubricate bolts and run nuts down by hand.
 - d. By using torque wrench, tighten nuts in the proper sequence so gasket is compressed evenly, and to the appropriate torque specified by bolt manufacturer taking into account the type of lubricant used.
4. HPS, HPC, and HPR
- a. Pitch main downs at 1¼" per 10'-0" in direction of steam/condensate flow unless noted otherwise. Install drip traps at each rise and at horizontal termination of each steam main. Unless otherwise indicated, use eccentric fittings for changes in horizontal pipe sizes with fittings installed for proper condensate drainage (bottom of pipe straight). Concentric fittings may be used for changes in vertical pipe sizes.
 - b. For steam branch connection and run outs, use side or top 45° connection to main.

- c. For condensate branch connection to condensate main, use side or top 45° connection to main.
 - d. For condensate connection from steam main, use bottom connection to main.
 - e. In the event that the insulation and interior carrier pipe of the pre-engineered direct buried piping is subjected to flooding or is exposed to water, the Contractor shall provide dew point monitoring system, air compressors, desiccant dryers and other materials and equipment required for drying of the piping insulation prior to activation of the steam line. Air injected into the line for drying shall have a dew point of not more than -20 °F. All drying activities shall be approved and directed by the piping manufacturer.
5. Condensate Pumped Discharge (CPD)
- a. Pitch mains down at 1¼" per 10'-0" in direction of flow unless otherwise noted. In limited space situations and where specifically indicated on drawings, horizontal lines may be run dead level. Where two separate pump discharge mains join together, provide check valve in each line before tee. Provide gate valve between check valve and tee for line isolation in an accessible location.
 - b. In the event that the insulation and interior carrier pipe of the pre-engineered direct buried piping is subjected to flooding or is exposed to water, the Contractor shall provide dew point monitoring system, air compressors, desiccant dryers and other materials and equipment required for drying of the piping insulation prior to activation of the condensate line. Air injected into the line for drying shall have a dewpoint of not more than -20 °F. All drying activities shall be approved and directed by the piping manufacturer.
6. Piping System Pressure Tests
- a. Pneumatic testing procedures and safety measures are required to be reviewed with the VT PM prior to completing.
 - b. Steam Systems:
 - i. Coordinate pressure tests with the A/E and the VT PM at least 3 working days in advance of its occurrence and conduct tests in presence of the A/E and/or the University's representative.
 - ii. Conduct hydrostatic (hydro) test for carrier piping with test medium of water unless specifically indicated.
 - iii. Conduct a pneumatic test for the inner conduit with test medium of air unless specifically indicated.
 - iv. If leaks are found, repair with new materials and repeat test.

- v. Pressure tests may be made of isolated portions of piping systems to facilitate general progress of installation. Any revisions made in piping systems require retesting of affected portions of piping systems.
 - vi. No systems shall be insulated until it has been successfully tested. If required for additional pressure load under test, provide temporary restraints at expansion joints or isolate them during test. Minimum test time to be 4 hours plus such additional time as may be necessary to conduct examination for leakage.
 - vii. No pressure drop shall occur during test period. Any pressure drop during test period indicates leakage.
 - viii. Provide pumps, appropriately scaled and calibrated, gauges, instruments, test equipment, temporary piping and personnel required for tests and provide removal of test equipment and draining of pipes after tests have been successfully conducted.
 - ix. For hydrostatic tests, remove air from piping being tested by means of air vents or loosening of flanges. Measure and record test pressure at high point in system. Where test pressure at high point in system causes excessive pressure at low point in system, due to static head, portions of piping system may be isolated and tested separately to avoid undue pressure. However, every portion of the piping system must be tested at the specified minimum test pressure.
 - x. Pneumatic test for outer casing shall be performed using a medium of dry air using desiccant dryers or nitrogen as recommended by the pipe manufacturer. During the pressure test, each weld on the outer casing shall be soap bubble tested using a water/dishwashing liquid mix. Each joint shall be coated with the mix and visually inspected to insure no leaks.
- c. Conduct Pressure Tests with parameters indicated below:

System	Test Pressure	Remark
HPS and CPD Inner conduit	15 psig	PNEU
HPS and CPD	225 psig	HYDRO

7. Flushing and Cleaning of Steam and Condensate System
 - a. Contractor shall visually inspect internal portion of each length of pipe during installation. Remove all dirt and foreign matter prior to installing additional lengths.
 - b. Pull a pig through each pipe, max length of pull is 100 feet. This will require leaving the piping open at the ends for access for the pig. TIG weld root passes on piping connections to prevent slag buildup in final connections.
 - c. Fill piping with water and conduct the specified hydrostatic pressure testing and completely drain system to system low point(s).
 - d. Use portable pumping apparatus for continuous 24 hour minimum circulation of cold water detergent. The basis of design for detergent shall be Nalco 2567 cleaner or similar. Flush detergent clear with continuous draining and raw water fill for additional 12 hours or until all cleaner is removed from system. Replace strainers and reconnect all apparatus bypassed.
 - e. Sectionalize system to obtain minimum velocity of 4 fps flow velocity or as otherwise recommended by chemical provider. Provide temporary piping to connect dead-end headers at boiler and connection points as necessary. Flush bottoms of risers.
 - f. Provide temporary piping or hose to bypass any component, which may be damaged, unless acceptable means of protection are provided and subsequent inspection of hide-out areas takes place.
 - g. All cleaning and flushing shall be performed such that all debris will be pulled or flushed downhill.
 - h. Contractor shall provide access at all low points through valves, tees, flanges, etc., to facilitate the cleaning and flushing process. If temporary fittings or piping is required it shall be provided by the Contractor and removed by the Contractor after successful cleaning.
 - i. After flushing and cleaning is completed, Contractor shall provide necessary pipe and fittings required to complete the piping system. Each cleaned section of piping shall be capped and protected to keep mud, debris, water, etc., from entering the piping. If a piping section is left open or unprotected, or is found to be contaminated, it shall be re-cleaned prior to being filled and activated at no cost to the University.
 - j. Contractor shall provide all water for flushing and cleaning. Coordinate rental of fire hydrant meters with local fire department, or the utility owner.

- k. Contractor shall provide all temporary piping from water source to piping system and shall provide means for conducting cleaning water from underground piping system to the appropriate sewer (pumps, piping, hoses, tanks, etc.). Contractor to remove all temporary piping, pumps, hoses, etc., from site immediately after flushing has been completed.

4.7.12 Steam Piping Specialties

1. Pipeline Strainer
 - a. Manufacturers: Mueller Steam Specialty, Hoffman, Armstrong, Illinois, or approved equal.
 - b. Steam and Condensate System:
 - i. 2" and Smaller – full pipeline size, “Y” type, Class 300, steel, socket weld ends with removable screen caps. Screen caps to have socket weld blowdown connection.
 - ii. 2½" and Larger – full pipeline size, “Y” type, Class 300, steel, weld ends. Furnish strainer with bolted screen retainer and off-center socket weld blowdown connection.
 - iii. Steam Service Screens – constructed of monel with 20 mesh or 1/32" diameter perforation for sizes through 2" and 3/64" or 0.045" diameter perforation for sizes over 2" Net area of screen to be at least 4 times that of connected pipe.
 - iv. Installation – Install in the horizontal position, not in the down position.
2. Steam Traps
 - a. Manufacturers: Spirax/Sarco, Nicholson (Illinois), Armstrong, Hoffman, or Watson McDaniel.
 - b. Trap bodies and trim shall be suitable for pressure classification with which they are used, but not less than 250 psig working pressure.
 - c. Traps shall have side inlet and side outlet connections to allow for complete maintenance of the trap trim without removing it from the piping system. Traps shall have threaded end connections.
 - d. Unless otherwise indicated, size traps as scheduled. Minimum trap size is ¾" for all types.
 - e. Do not insulate thermostatic traps.
 - f. Inverted Bucket Traps: Cast Iron body with renewable cover, stainless steel bucket, and stainless steel valve mechanism assembly.
3. Pressure Gauges (Low Pressure Steam, High Pressure Steam, Pumped Condensate)

- a. Manufacturers: Ashcroft, U.S. Gauge, Marsh, Taylor, Trerice, Marshalltown, or Weiss equal to Trerice 700 Series.
- b. Minimum 4" diameter, liquid filled, 304 stainless steel case, glass window, bronze tube, brass socket, stainless steel movement, 1¼" NPT connection.
- c. Gauge accuracy shall be 1.0% full scale.
- d. Reading range of gauges shall be:

<u>Service</u>	<u>Scale Range</u>
Low Pressure Steam	30" mercury vacuum to 30 psig
High Pressure Steam	0 to 200 psig
Pumped Condensate	0 to 160 psig

- e. Coil Siphons: ¼" or ½" size, matching gauge pipe size, 1000 psig WP. Material shall match gauge pipe material.
- f. Gauge Piping: All gauge piping shall be schedule 40 black steel, minimum size ¾".
- g. Gauge Valve: Provide gate valves for steam, condensate and pumped condensate. See figure below.

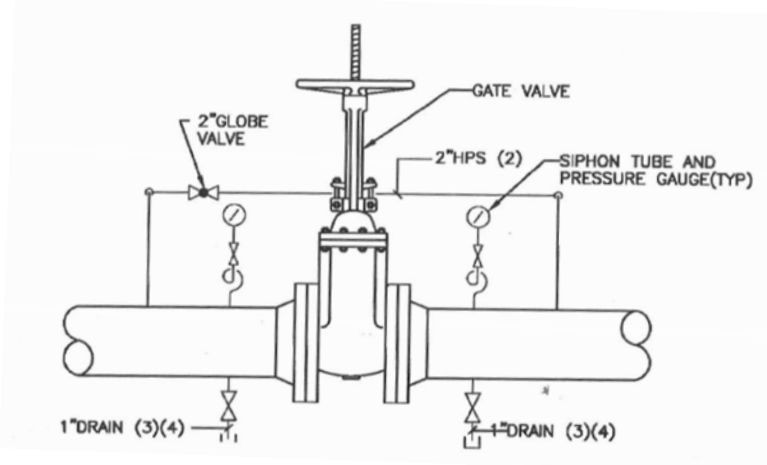

4. Expansion Devices

a. Expansion Joints (Slip Type):

- i. Manufacturers: Advanced Thermal Systems Type TP2, ADSCO Type RJ, Yarway Type W, or Hyspan equal to Advanced Thermal Systems Type TP2.
- ii. Slip type expansion joints to permit injection of self-lubricating packing under full line pressure. Internal and external guides to be integral with stuffing box. Provide outward limit stop to prevent disengagement of slip from body in event of main anchor failure.

- iii. Joints to be constructed from A-53 Grade B, Schedule 80, seamless carbon steel pipe with 150# flanged end connections. Slip joint to be ground and polished to 16 RMS and then plated with 1 mil of hard chrome applied over 1 mil of crack-free hard chrome. Internal and external guide surfaces in contact with chrome plated slip to have flexible nonmetallic Low Friction Inserts to prevent scoring or binding of slip (metal inserts are not allowed). Guide inserts shall be rated for 600 °F.
- iv. Packing ram cylinders shall be minimum of 2" diameter having internal acme thread and integral stainless steel shut off valve. Packing ram cylinders shall be welded to joint, threaded connections are not allowed. Stuffing box shall be fully packed with self-lubricating flake graphite injectable packing and reinforced graphite ring packing. Area of packing in contact with slip to be minimum of 15 times nominal pipe size. Injectable packing shall be asbestos free and rated for 1000 °F.
- v. Design joints for working temperature and pressure suitable for application, but not less than 150 psig, and continuous operating temperature of 600 °F.
- vi. Furnish minimum of 0.80 cubic inches spare injectable packing in plug form for each packing cylinder of each expansion joint.
- vii. Provide insulating blankets rated for 550 °F and damp and salt exposure conditions. Blankets shall have inner and outer protective cover and designed to allow for service of the packing cylinders without removal of the blanket. Insulating blankets shall be manufactured by the joint manufacturer. Field made insulation blankets are not allowed.
- viii. Expansion joints shall be provided with a minimum 5-year leak free warranty.
- ix. Contractor shall be responsible for pre-compressing joints to allow for difference between installation temperature and minimum design temperature.
- x. Anchors and guides shall be installed per the project documents and per the manufacturers guidelines prior to conducting piping system pressure tests or putting joints into service. Anchors shall be designed for cracked concrete.

5. Pipeline Strainers
 - a. Provide drain valve at each strainer blowdown connection with hose threaded adapter and cap. Valve size to be same as blowdown connection size.
 - b. Install strainers in steam system at inlet to steam traps and pressure reducing valves.
 - c. Orient strainers so that full screen flow is achieved and not blocked by condensate accumulation.
 - d. Install drain valve in each blow-off connection.
6. Steam Traps
 - a. Install steam traps at locations where end of main drips are required. Provide steam main drip/traps at intervals not to exceed 400 feet and anywhere a low spot is created.
 - b. Install traps to gravity flow to trap in accordance with trap manufacturer's guidelines.
 - c. Unless specifically shown, do not lift condensate from discharge of any trap without written permission of VT PM.
 - d. Support traps weighing over 25 pounds independently of connecting piping.
 - e. High pressure condensate shall not be put directly into low pressure or piped condensate lines.

4.7.13 Steam Distribution Pipe Insulation

1. Definitions: This section applies to pipe installed in a steam tunnel.
2. Manufacturers: Owens-Coming, Pittsburgh Coming, Schuller International (Manville), Knauf or Manson similar to product indicated except where product of another manufacturer is specifically identified for special type of insulation.
3. Insulation:
 - a. Fire retardant, moisture and mildew resistant, vermin proof, and suitable to receive jackets, adhesives and coatings as indicated.
 - b. Glass fiber insulation, where indicated, shall be of inert inorganic material, non-corrosive to mechanical surfaces.
 - c. Insulating cement shall have a dry density of no more than 38 lb./cu. ft. and thermal conductivity of 0.63 at 400 °F mean temperature.
 - d. Filling and finishing cement shall have a dry density of no more than 24 lb./cu. ft. and thermal conductivity of 0.74 at 500 °F mean temperature.

- e. Type G Insulation (Cellular Glass): 100% cellular glass cells with no organic material, noncombustible, 0.00 perm-inch permeability, 8.5 lb./cu. ft. average density, compression strength 100 psi, and thermal conductivity of not more than 0.36 at 50 °F mean temperature. The basis of design shall be Pittsburgh Corning FOAMGLAS® or approved equal.
 - f. Type M insulation (Mineral Wool Pipe Covering): Mineral fiber pre-molded pipe insulation, in accordance with ASTM C-547, Type II, Grade A, nominal 8 lb./cu. ft. density, water resistant, non-wicking, suitable for continuous temperature through 1200 °F, thermal conductivity not more than 0.31 at 200 °F and 0.41 at 400 °F mean temperature, Fibrex Coreplus 1200, Roxul1200, or IIG MinWool-1200.
4. Jackets
- a. Jackets puncture resistance based on ASTM-D-781 test methods. Vapor barriers perm ratings based on ASTM E-96 procedure A.
 - b. Type A-1 Jacket:
 - i. Factory fabricated 0.016" thick, ASTM B209, Type 3003 embossed aluminum jacket, complete with integral longitudinal Pittsburgh Z-Lock seam.
 - ii. Fitting covers to be factory fabricated from not lighter than 0.024" thick, type 3003 aluminum.
 - c. Type P-1 Jackets: Heavy-duty, fire retardant material with glass fiber reinforcing and self-sealing lap. Jacket shall have neat, white Kraft finish suitable for painting, with beach puncture resistance of 50 units minimum. Vapor barrier shall be 0.0005" aluminum foil adhered to inner surface of jacket. Permeance shall not exceed 0.02 perm. Cover jacket with 30# builders felt. Builders felt shall be secured every 18 inches with stainless steel wire or stainless steel bands.
5. Metal Bands and Wires
- a. Aluminum bands to be 0.5" × 0.020" up to 48" O.D. and 0.75" × 0.020" over 48" O.D.
 - b. Stainless steel bands to be 0.5" × 0.015".
 - c. Stainless steel wires to be 16 gauge.
6. Removable Insulating Blankets
- a. Custom designed removable, reusable, flexible, blanket thermal insulation system.
 - b. Acceptable Manufacturers: Thermal Energy Products, Inc., Advanced Thermal Corp. and Remco Technology, Inc.

- c. Removable insulation system shall be custom designed for each individual item to provide close contour fit. Overlapping seams and gaps are not acceptable.
- d. Removable insulation shall be designed to overlap adjoining pipe insulation by 2 inches.
- e. Insulation: Minimum 2" thick, 2.4 lb./cu. ft. density, 1000 °F thermal insulating wool.
- f. Interior and Exterior Fabric: 17.5 oz./sq. yd. silicone rubber coated fiberglass cloth.
- g. Securement: Blanket seams shall be closed with buckle and strap assembly (D-ring closure).
- h. Identification tagging: Label each removable insulation device with 304 stainless steel tag with raised letters.

7. Execution

Applications: Provide Insulation and jackets as indicated in the following schedule. The schedule applies to both exposed and concealed applications unless noted otherwise:

Service	Jacket Type	Insulation Type	Insulation Thickness According to Pipe Size		
			1" to 2"	3" to 4"	5" and Larger
HPS and CPD in Manholes	A-1	G	2½"	3"	3"
HPS in Existing Tunnel	P-1	M	2½"	3"	3"
CPD and HPR in Existing Tunnel	P-1	M	1½"	2"	3"
HPR in Manholes	A-1	G	1½"	-	-
HWS and HWR in Existing Tunnel	P-1	M	N/A	1½"	2"

8. Installation – General

- a. Install all products with good workmanship, with smooth and even surfaces. Use full length factory furnished material where possible. Does not use scrap piecing.
- b. Apply insulation only on clean, dry surfaces, after all rust and scale have been removed and testing of systems has been completed. Do not insulate any section of system which must be pressure tested until after it has been successfully tested. Any removal and reinstallation to correct system defects, prior to end of guarantee period shall be accomplished at no expense to University.
- c. Install insulating materials with necessary joints and terminations, to permit easy access and removal of equipment sections where inspection or frequent service or repair is required, and to allow for expansion.

- d. Provide beveled terminations at all name plates and un-insulated fittings.
 - e. Make longitudinal joints in jackets, where possible, facing toward wall or ceiling.
 - f. Apply insulation to each pipe individually. Common insulation applied for adjacent pipes will not be accepted.
 - g. Unless otherwise indicated, pipe insulation shall be continuous through not-rated walls and floors.
9. Type G insulation (Cellular Glass): Install cellular glass in strict accordance with manufacturer instructions.
10. Type A-1 Jacket:
- a. Unless otherwise indicated, install shields (A-1 jacket) around all insulated pipe and fittings within manholes and tunnels. Seal water and vapor tight at terminations.
 - b. Longitudinal overlap shall be at least 2" wide with vapor barrier sealant.
 - c. Secure jacketing with ¾" wide 0.020 stainless steel or aluminum strapping and wing seals on maximum 18" centers.
11. Piping, Valve, and Fitting Insulation
- a. Install removable insulating jackets on the following devices:
 - i. All steam valves 4" size and larger
 - ii. All condensate valves 4" size and larger.
 - b. Apply insulation to pipe, and fittings with butt joints and longitudinal seams closed tightly. Valves and expansion joints shall have removable insulation blankets as specified.
 - c. Laps on factory applied jackets shall be 2" minimum width firmly cemented with lap adhesive, or be pressure sealing type lap.
 - d. Where terminations of pipe insulation are required, insulation shall have tapered ends, built up and finished as specified for fittings.

4.7.14 Electrical Utilities

4.7.14.1 Typical Outdoor Pad Mounted Construction Standards

This standard is for use concerning areas where outdoor pad mounted equipment is acceptable. The following standards will apply for the electrical service installation based upon the size of the service installation.

4.7.14.1.1 Small Size – Electrical Service

- 1. Defined:
 - a. There is one transformer.
 - b. There is NOT a secondary connection cabinet.
 - c. There are less than 6 secondary conductors per phase.

- d. Secondary conductors are not longer than 125 feet.
2. General / A/E Requirements:
- a. At the pad mounted transformer location, the Virginia Tech Electrical Service (VTES) requires a high voltage primary selective switch. The switch will be an S&C PMH-9 source automatic transfer switch or S&C PMH-9 manual switch depending on building needs. VTES requires 8 feet minimum of working space on the switch and fuse compartment sides and 3 feet of working space on the control sides of the switch. Refer to the drawing of a typical PMH-9 switch pad layout in the VTES details located in the VT Design Standard Detail Library.
 - b. VTES requires 8 feet minimum of working space on the front of the transformer. Refer to the drawing of a typical transformer pad layout in the VTES details located in the VT Design Standard Detail Library. Working space provided through gates or double door openings is acceptable to VTES. If working space is through a gate, the gate shall be provided with hasp mechanism for a padlock supplied by VTES. Gates on double doors shall swing clear of working space if access for other personnel, such as generator maintenance, is needed to the area. More than one gate may need to be provided with the appropriate lock/keying for other personnel besides VTES.
 - c. Utility metering will be at the transformer location. Metering at a dedicated transformer can be done in the transformer secondary compartment if the installation is six or less 500 MCM Copper, (or 600 MCM Aluminum), or smaller conductors per phase in the building service and the conductors must not be longer than 125 feet. This requirement excludes any conductors for site lighting and temporary service referenced below.
 - d. A/E is responsible for VTES equipment layout, pads, and required clear working space around VTES provided equipment. Crane or line truck access for VTES equipment shall be identified and reserved in VTES equipment layout plan. The maximum equipment weight is based on line truck capabilities. Consult VTES to determine the current equipment capabilities.
 - e. Any required ESC Plan shall be part of the project documents and in accordance with the VTAS&S. The permitted site plan shall include the route from the existing primary distribution system to the location of the new service equipment.

3. Contractor Requirements:
 - a. If a contractor has been selected and approved by VTES to build the electrical installation, this section describes the requirements for that construction.
 - b. The Contractor is responsible for bringing the secondary concrete encased service duct bank and conductors from the building back to the transformer location.
 - c. The Contractor is also responsible for the high voltage switch pad and transformer pad, including conduit install per VTES layout drawing. Coordination between the Contractor and VTES is required. Contact VTES for specific pad details, conduit routing, and required sizes.
 - d. The transformer and high voltage switch pads shall have a fiberglass box pad installed in conjunction with the concrete pads. The fiberglass pads create a well under the transformer and high voltage switch. The fiberglass box pads will be provided by VTES for contractor installation. Box pads shall be VTES field coordinated with the Contractor during pad construction. The top of the fiberglass box pads shall be level and flush with the top of the concrete pad.
 - e. The high voltage switch shall have two ground rods in opposite corners inside the switch well. Refer to the switch pad layout detail in the VTES details located in the VT Design Standard Detail Library.
 - f. The transformer pad shall have a ground rod located in the high voltage compartment area. Refer to the transformer pad layout detail in the VTES details located in the VT Design Standard Detail Library.
 - g. The Contractor shall provide and install a service to be used to serve future temporary functions or events in the transformer service area. One 2-inch schedule 40 PVC conduit with service conductors from the transformer's low voltage compartment to a 200 amp fused disconnect shall be provided. The electrical disconnect shall be rated as NEMA 3R for outdoor installations and can be located on a wall or rack. The conduit shall be provided and installed by the Contractor. Conduit shall be capped to prevent debris from entering conduit until electrical install has been completed.

- h. The Contractor is responsible for all conduits used with metering and SCADA related to installations particularly at the transformer and switch pads. See conduit requirements and drawings in the VTES details located in the VT Design Standard Detail Library. Consult VTES with any questions on specific requirements.
 - i. All conduit stub-ups shall be plumb and conduit shall be spaced sufficiently to allow installation of couplings and locknuts. All conduits shall have caps placed on the conduits, but not glued, prior to pouring concrete. Conduits shall be free of foreign objects including gravel and concrete. VTES may require a validation of clean conduit through the use of pulling a mandrel through the conduit as needed. Pull strings shall be installed in conduits.
 - j. The Contractor shall be responsible for all hardscape and landscaping remediation along the primary duct bank path.
 - k. The Contractor is responsible for all installation and usage charges for temporary power associated with the project. Estimates are provided per each request.
 - l. Any required ESC Plan shall be part of the project documents and in accordance with the VTAS&S. The permitted site shall include the route from the existing primary distribution system to the location of the new service equipment.
4. VTES Requirements:
- a. All primary work, primary conductors, primary duct bank, high voltage switch, transformer, and metering are normally provided and installed by VTES and shall be paid for by the project. See DCSM section 4.7.14.5 for more details.
 - b. Termination of the contractor-installed secondary feeder conductors on the transformer will be completed by VTES. The Contractor shall install the secondary cables and VTES will terminate the cables at the transformer's secondary compartment.

4.7.14.1.2 Large Size – Electrical Service

- 1. Defined:
 - a. At least one transformer.
 - b. At least one secondary connection cabinet.
 - c. There are more than 6 secondary conductors per phase.
 - d. Secondary conductors may be longer than 125 feet.

2. General / A/E Requirements:
 - a. At the pad mounted transformer location, VTES requires a high voltage primary selective switch. The basis of design for transfer switches shall be S&C Electric Company products. The switch will be an S&C PMH-9 source automatic transfer switch or S&C PMH-9 manual switch depending on the building needs. VTES requires 8 feet minimum of working space on the switch and fuse compartment sides and 3 feet of working space on the control sides of the switch. Refer to the drawing of a typical PMH-9 switch pad layout in the VTES details located in the VT Design Standard Detail Library. An S&C Vista switch is an acceptable alternative. Vista switches may require venting. Consult with VTES prior to installation.
 - b. VTES also requires 8 feet minimum of working space on the front of the transformer. Working space provided through gates or double door openings is acceptable to VTES. If working space is through a gate, the gate shall be provided with a hasp mechanism for a padlock supplied by VTES. Gates on double doors shall swing clear of working space if access for other personnel, such as generator maintenance, is needed to the area. More than one gate may need to be provided with the appropriate lock/keying for other personnel besides VTES.
 - c. Secondary connection and metering cabinets located adjacent to the transformer are needed if there are multiple metered services provided from the transformer. If a service requires more than 6 conductors per phase, (excludes site lighting service and temporary service conductors) then secondary connection and metering cabinets are also needed. The secondary connection cabinet is 42" W × 42" D × 53" H. Metering will be installed at or near this secondary cabinet location. VTES requires 5½ feet of working space on the two sides of the cabinet that has doors. Refer to the typical layout drawings in the VTES details located in the VT Design Standard Detail Library.
 - d. A/E is responsible for VTES equipment layout, pads, and required clear working space around VTES provided equipment. Crane access for VTES equipment shall be identified and reserved in the VTES equipment layout plan.
 - e. Any required ESC Plan shall be part of the project documents and in accordance with the VTAS&S and shall be the responsibility of

the project. The permitted site plan shall include the route from the existing primary distribution system to the location of the new service equipment.

3. Contractor Requirements:
 - a. The Contractor is responsible for bringing the secondary concrete encased service duct bank and conductors from the building back to the secondary connection cabinet location.
 - b. Should site logistics or other concerns cause the project team to desire the Contractor to perform portions of the primary duct bank installation work, VTES will entertain this option.
 - c. The Contractor is responsible for the high voltage switch pad, transformer pad, and secondary connection cabinet pad. Coordination between the Contractor and VTES is required. Contact VTES for specific pad details.
 - d. The transformer, secondary connection cabinet, and high voltage switch pads shall have a fiberglass box pad installed in conjunction with the concrete pads. The fiberglass pads create a well under the transformer, secondary connection cabinet, and high voltage switch. The fiberglass box pads will be provided by VTES for contractor installation. Box pads shall be VTES field coordinated with the contractor during pad construction. The top of the fiberglass box pads shall be level with the top of the concrete pads.
 - e. The transformer pad shall have a ground rod located in the high voltage compartment area. Refer to the drawing of typical transformer pad layout in the VTES details located in the VT Design Standard Detail Library.
 - f. The secondary connection cabinet pad shall have a ground rod located inside the cabinet area. Refer to the drawing of typical pad layout in the VTES details located in the VT Design Standard Detail Library.
 - g. The high voltage switch shall have two ground rods in opposite corners inside the switch.
 - h. The Contractor shall provide and install a service to be used to serve future temporary functions or events in the transformer service area. One 2-inch schedule 40 PVC conduit with service conductors from the transformer's low voltage compartment to a 200 amp fused disconnect shall be provided. The electrical disconnect shall be rated as NEMA 3R for outdoor installations

and can be located on a wall or rack. The conduit shall be provided and installed by the Contractor. Conduit shall be capped to prevent debris from entering conduit until electrical install has been completed.

- i. The Contractor is responsible for all conduits for metering and SCADA in the transformer and switch pads. See conduit requirements in the VTES details located in the VT Design Standard Detail Library.
 - j. All conduit stub-ups shall be plumb and conduit shall be spaced sufficiently to allow installation of couplings and locknuts. All conduits shall have caps placed on the conduits, but not glued, prior to pouring concrete. Caps prevent debris from entering the conduits. All conduits shall also have pull strings attached.
 - k. All conduit stub-ups shall be plumb and conduit shall be spaced sufficiently to allow installation of couplings and locknuts.
 - l. The Contractor shall be responsible for all hardscape and landscaping remediation along the primary duct bank path.
 - m. The Contractor is responsible for all installation and usage charges for temporary power associated with the project.
 - n. Any required ESC Plan shall be part of the project documents and in accordance with the VTAS&S. The permitted site shall include the route from the existing primary distribution system to the location of the new service equipment.
4. VTES Requirements:
- a. All primary feeder work, primary conductors, primary duct bank, high voltage switch, transformer, metering, and secondary connection cabinet are normally provided by VTES and paid for by the project.
 - b. VTES will provide conductors from the transformer to the secondary connection cabinet and terminate the secondary conductors on the utility transformer end and all conductors in the secondary connection cabinet.
 - c. All metering equipment including the meter, current transformers (CTs), and potential transformers (PTs) will be provided and installed by VTES.
5. Conduit Requirements for Pad Mounted Service Transformer, Related Metering, and SCADA:
- a. The Contractor shall provide one 1½-inch schedule 40 PVC conduit from the transformer secondary compartment, (or secondary

connection cabinet if used), to the meter location for metering. The meter location shall be within 30 conduit feet of the transformer, (or secondary connection cabinet if used), the motor location must be readily accessible to the transformer and secondary cabinet to facilitate testing. The meter can be wall or rack mounted. For 480 volt services, the PTs will be mounted in an Aluminum 24" L × 24" W × 10" D and NEMA 3R rated junction box under the meter.

- b. The Contractor shall provide one 1-inch schedule 40 PVC conduit from the high voltage switch to the meter location for SCADA controls. For an automatic source transfer switch this shall be from the control compartment. For a manual switch this shall turn up just outside one of the fuse compartments with a second conduit stubbed into the switch well. Utilize a NEMA 3R junction box to join the two conduits into a complete raceway. Refer to the drawing of typical pad layout in the VTES details located in the VT Design Standard Detail Library.
 - c. If a lighting pedestal/control is installed, one 1-inch conduit shall be extended from the SCADA location to the lighting pedestal. Refer to the drawing of typical pad layout in the VTES details located in the VT Design Standard Detail Library.
 - d. The primary duct bank installed by VTES will have one 2-inch conduit for SCADA communication that will extend to the meter location.
 - e. All conduit stub-ups shall be plumb and conduit shall be spaced sufficiently to allow installation of couplings and locknuts. All conduits will be capped but the cap will not be glued prior to pouring concrete.
6. Exceptions for Outdoor Pad Mounted Construction Standards for Small Scope Projects
- a. New small services including but not limited to traffic lights and steam tunnel service as well as services installed in farm areas and services installed from existing transformers must be coordinated with VTES.
 - b. Concrete pads for the high voltage switch and transformer shall be installed by VTES or the contractor depending on the scope of the project.
 - c. All 3-phase services up to 200 amps and 240-volt single phase service up to 400 amps will be metered with socket based meters.

- d. PTs and CTs are required for all 480 volt services. Metering shall be located near the transformer or near the load.
- e. Depending on the scope of the project, VTES or the Contractor may provide and install service conduit and conductors.
- f. If VTES determines that concrete encased secondary duct bank from the transformer to the service entrance equipment is required, then it shall be provided and installed by the Contractor.
- g. If a switch or transformer is required, VTES requires 8 feet minimum of working space on the switch compartment sides of this switch, 8 feet minimum on the fuse compartment sides and 3 feet of working space on the control sides. VTES requires 8 feet minimum of working space on the front of the transformer. Refer to the drawing of typical transformer pad layout in the VTES details located in the VT Design Standard Detail Library. Working space provided through gates or double door openings is acceptable to VTES. If working space is through a gate, the gate shall be provided with hasp mechanism for a padlock supplied by VTES. If access for other personnel is needed to the area, such as generator maintenance, provide another gate with appropriate lock and keying.

4.7.14.2 Outdoor Below Ground Vault Construction Standards

If an outdoor below ground vault is provided, the requirements and installation will be similar to the pad mount standards with the following additions.

- 1. General / A/E Requirements
 - a. The bottom of the vault must be above the floodplain.
 - b. There shall be a low point well and sump pump with associated drain piping, power, and float controls. Sump pump shall be wired to an emergency circuit.
 - c. Access at grade level, if the vault is built into a bank with a door through the wall, or a stairwell is preferred.
 - d. If ladder access is required then a safety railing around the entrance is required. If the top of the ladder is flush with grade, engineered hand holds or retractable ladder extensions are required.
 - e. Natural or mechanical ventilation shall be provided to maintain a 40 °C maximum ambient for the equipment. If access is via ladder, mechanical ventilation will be required with local control at the point of entry.

- f. A minimum of one light shall be on the building emergency circuit with a switch at the point of entry. If there is minimal natural lighting available when the door is closed then lighting shall be provided to meet the NEC.
 - g. Metering shall be wall mounted.
 - h. Provisions shall be made for a 48" H × 36" W × 12" D clear wall space for mounting VTES-supplied SCADA and metering equipment. We require a minimum of a 36-inch clear working space in front of the SCADA and metering equipment, for a total of 48-inch depth space from wall.
2. Contractor Requirements
- a. At least two ground rods shall be installed in opposite corners of the vault.
 - b. Construction of vault will be by the Contractor and shall include conduits for metering, SCADA, lighting, 120-volt receptacle, and sump pump circuit.
 - c. VTES requires at least one receptacle to be fed from the building emergency circuit in the SCADA/meter area. If the building emergency circuit is not available, a normal power fed receptacle is acceptable. Label the receptacle and identify the source of power.
 - d. VTES must approve drawings for any outdoor below grade vaults prior to construction. Consult with VTES as needed.

4.7.14.3 Indoor Vault Construction Standards

For areas where the transformer will be located in the building the following sections will apply for the electric service installation.

4.7.14.3.1 Manhole and Duct Bank

- 1. General / A/E Requirements
 - a. All duct banks shall be inspected by VTES before the Contractor pours concrete.
 - b. The concrete encased duct bank will contain four 5- or 6-inch conduits for the primary. Please note that older legacy duct bank connections may require four 4-inch conduits. However, 5- or 6-inch conduits are typically preferred. Refer to the drawing of a typical duct bank layout in the VTES details located in the VT Design Standard Detail Library. Consult with VTES to determine the proper size for the installation location. The conduits will

extend from the manhole to the appropriate compartments of the high voltage switch.

- c. A secondary duct bank will contain two 6-inch conduits. The ducts shall extend from the manhole to an area outside but adjacent to the low voltage compartment of the transformer. Refer to the drawing of a typical duct bank layout in the VTES details located in the VT Design Standard Detail Library.
 - d. The Contractor shall provide and install a minimum 8 ft. by 8 ft. by 6½ ft. high (inside dimensions) manhole within 10 feet of the outside of the building. Refer to the drawing of a typical manhole layout in the VTES details located in the VT Design Standard Detail Library.
 - e. Any required ESC Plan shall be part of the project documents and in accordance with the VTAS&S. The permitted site shall include the route from the existing primary distribution system to the location of the new service equipment.
2. Contractor Requirements
- a. VTES will typically build all concrete encased duct bank for the primary cables. However, in cases where VTES has authorized a Contractor to build concrete encased duct bank, the following requirements shall be achieved. All duct bank construction must be approved by VTES prior to any build activities through the use of complete drawings supplied by the Contractor and/or A/E firm. In such cases, the following general requirements would need to be met. Other requirements may also be noted after the drawing review. Refer to the drawing of a typical duct bank layout in the VTES details located in the VT Design Standard Detail Library.
 - b. The Contractor shall provide and install a minimum 8 ft. by 8 ft. by 6½ ft. high (inside dimensions) manhole within 10 feet of the outside of the building per VTES standards.
 - c. The Contractor shall provide and install a concrete encased duct bank from the manhole into the room, (vault), in the building containing the high voltage switch and transformer.
 - d. VTES is responsible for installation of the primary cable and termination on the transformer and on the load break elbows in the manhole. If a contractor has been authorized to install cabling, VTES power line worker(s) must be present during the installation. Consult with VTES prior to construction.

- e. The concrete encased duct bank will contain four 5- or 6-inch conduits for primary as determined by VTES. The conduits will extend from the manhole to the appropriate compartments of the high voltage switch.
 - f. The duct bank will also contain one 2-inch conduit for SCADA communications that will extend from the manhole to the SCADA cabinet.
 - g. The secondary duct bank shall also contain ducts of the size and number needed for a conductor equivalent to the building secondary service size. These ducts will extend from the manhole to an area outside but adjacent to the low voltage compartment of the transformer.
 - h. There shall also be one 2-inch duct from the manhole to temporary a service disconnect. See DCSM section 4.7.14.3.6.
 - i. All ducts shall have pull strings installed.
 - j. All conduit stub-ups shall be plumb and conduit shall be spaced sufficiently to allow installation of couplings and locknuts. All conduits shall be capped, but not glued prior to pouring concrete.
 - k. All duct banks shall be inspected by VTES before contractor pours concrete. All conduits must be free of foreign objects. VTES may require and specify a mandrel pull to be witnessed by VTES personnel to avoid foreign objects in the conduit.
 - l. Any required ESC Plan shall be part of the project documents and in accordance with the VTAS&S. The permitted site shall include the route from the existing primary distribution system to the location of the new service equipment.
3. VTES Requirements:
- a. VTES will provide duct bank and primary conductors to the manhole outside the building.
 - b. The manhole must have a ground installed in opposing corners of the manhole per VTES standards. Refer to the drawing of a typical manhole layout in the VTES details located in the VT Design Standard Detail Library.
 - c. VTES will provide load break junction points in the manhole. A four-way junction is the minimum requirement. Larger junctions may be required, consult with VTES.
 - d. VTES will also require cable racking per VTES standards. Consult with VTES for further details.

- e. VTES will also provide and install the utility metering as further described below. (See DCSM section 4.7.14.5 for more details).

4.7.14.3.2 Vault

A vault shall be provided and is the responsibility of the Contractor as part of the project:

1. Sufficient site to accommodate medium voltage switch, transformer, metering, SCADA equipment, and associated clear working space.
2. Ventilation sufficient to maintain a maximum 40 °C temperature on a day with maximum 30 °C outdoor temperature while the transformer is operating at full FA loading. Ventilation controls shall be at the point of personnel entry and fed from the building emergency circuit.
3. A minimum of one light shall be on the building emergency circuit. The light switch shall be at the point of entry.
4. At least one receptacle in the SCADA/meter area shall be on the building emergency circuit.
5. The basis of design for keyed access from the exterior of the building shall be Best Lock. VTES Best Lock is preferred because VTES personnel will not have building keys. Consult with VTES and the VT key shop on the lock series.
6. VTES requires an 8-foot minimum working space in front of the switch and transformer compartments that contain high voltage terminations or that would have exposed live parts when doors are open. VTES will accept a portion of this working space being available through double doors or rollup doors in the vault wall. Refer to the drawing of typical switch and transformer pad layouts in the VTES details located in the VT Design Standard Detail Library.

4.7.14.3.3 Medium Voltage Switch Requirements

The medium voltage switch shall meet the following specifications:

General / A/E Requirements

1. The switch shall be a utility grade switch with visible break. Vacuum circuit breakers that require racking out to witness the visible break are not acceptable. Commercial grade medium voltage interrupter switches meeting IEEE C37.22 are not acceptable due to the limitations of mechanical and electrical endurance capabilities.
2. The medium voltage switch shall be a primary selective switch. Manual or automatic operation of the switch will depend on the needs and requirements of the building.

3. Preferred switching shall be an air insulated load break style switch.
4. Transformer protection provided by this switch shall be fusing or vacuum interrupters. The basis of design for fusing shall be S&C SMU-20 power fuses or McGraw Edison type NX current limiting fuses with clip mounting, (mounting code 5 up to 30 amps, mounting code 6 for 50 through 100 amps), to match fusing stocked by VTES. Type NX fusing may also be used on transformers up to and including 1500 kVA. Vacuum interrupters shall have TCC curves which simulate these fuses.
5. Source-transfer switches driven by stored-energy operators are preferred.
6. Switches shall have de-couplers to permit exercising of the switch operators without affecting the positions of the switches.
7. One 24 VDC rated auxiliary contact to indicate the position of each switch shall be provided.
8. An empty 2-inch conduit from the compartment containing the terminal connection for the auxiliary contacts shall be extended to the SCADA/meter area and into the SCADA cabinet.
9. All medium voltage switch compartments shall have a ground rod installed in the equipment pad.
10. For automatic source transfer switches the transfer from one source to the other shall be accomplished in no more than 10 cycles plus any relay time delay for coordination. The transfer control shall be totally self-contained for programmed control of all switching functions associated with the automatic source transfer. Voltage sensors for sensing and control power shall be integral to the switchgear. The transfer control shall contain a "ready" indicator and corresponding auxiliary contact indicating that all controls and switches are ready for a transfer if a loss of source was sensed by the control.
11. The basis of design for source transfer switches and source transfer controls shall be S&C Electric Company products. For automatic operation, the switch shall be an S&C PMH-9 source transfer switch. Source transfer controls shall be S&C Micro-AT source transfer control. For manual operation, the switch shall be an S&C PMH-9 switch. An S&C Vista switch is an acceptable alternative. Vista switches may require venting. Consult with VTES prior to installation.
12. VTES requires 8 feet minimum of working space on the switch compartment sides of this switch and 3 feet of working space on the control sides. Working space provided through double door openings

is acceptable to VTES. Refer to the drawing of a typical switch pad layout in the VTES details located in the VT Design Standard Detail Library.

4.7.14.3.4 Indoor Building Transformer Requirements

The building transformer will be a dry-type vacuum pressure impregnated (VPI) or a cast coil transformer with the following specifications:

General / A/E Requirements

1. Applicable Standards: IEEE/ANSI C57.12.01, IEEE/ ANSI C57.12.50, IEEE/ANSI C57.12.91
2. The transformer shall be UL listed
3. kVA Rating and FA rating shall equal the building service size needs
4. Frequency: 60 Hz
5. Impedance: 5.75%
6. Windings: Aluminum or copper
7. Primary Voltage: 12.47 kV
8. Primary Taps: two 2.5% FCAN and two 2.5% FCBN
9. Primary Connection: Delta
10. Primary Termination: Air Terminal Chamber, (Standard ANSI Segment 2, or Segment 1 or 3 acceptable), for cable termination. Close coupling with the primary switch is not acceptable.
11. Secondary Voltage: 208 or 480 (as needed)
12. Secondary Connection: Grounded Wye
13. Secondary Termination: Air Terminal Chamber, (Standard ANSI Segment 4), for cable termination or close coupled with low voltage switchgear via flexible leads.
14. Application Location: Indoor NEMA 1
15. Sound Level: Standard
16. Winding Temperature Rise: 80 °C
17. Insulation system: 220 °C
18. Primary BIL: 95 kV minimum
19. Secondary BIL: 20 kV minimum
20. Forced Air Rating: AA/FA or AA/FFA
21. Digital three phase temperature monitor for fan control to provide local control and indication of temperatures and alarms with additional alarm output contacts for connection to utility SCADA system.
22. Surge arrestors: 15 kV distribution class arrestors shall be provided at the transformer high voltage terminals.

23. Provide IEEE/ANSI impulse testing in addition to standard tests.
24. VTES and the VT PM shall be provided with test reports including all standard IEEE/ANSI specified tests, impulse test, and loss evaluation.
25. The transformer pad shall have a ground rod located in the high voltage compartment area.

4.7.14.3.5 Utility Metering and SCADA Requirements

1. Provide utility metering compartment located ahead of the main service overcurrent device. All compartments containing unmetered conductors shall be lockable or sealable.
2. All bus shall be designed to withstand available fault currents.
3. The bus and current transformer mountings shall be designed so that each of the current transformers may be withdrawn from its mounting position directly through the access panel without disturbing any other current transformer or bus.
4. Provide IR type inspection windows in the compartment. Windows shall provide broadband transmission to support short, mid, and long wave IR cameras as well as visual inspections. Position windows so all CTs are visible from at least one window.
5. Provide metering accuracy CTs on all three phases, with polarity clearly marked. CTs shall have a 5-amp secondary and a primary rating equal to 50% of the transformer FA current rating. If this is not a standard CT rating then the next higher standard CT rating shall be used. CTs shall have a minimum rating factor of 2.0 at 30 °C. CT shall have a minimum 0.3B-0.5 accuracy and burden rating. CT shall have a CT manufacturer supplied shorting device as part of the CT. The shorting device shall be covered and capable of being sealed with a seal wire. This shorting terminal shall be accessible when the metering compartment is open. The CT shall be ABB type CLC or equivalent. All CTs that are not ABB shall be evaluated by VTES.
6. Provide CT mounting so rating information is visible from the IR inspection windows.
7. Provide phase to ground metering potentials for all three phases. Metering potentials shall be fused. For 480 volt services, provide metering accuracy PTs from phase to ground on all three phases. PTs shall have a ratio of 288:120 and a thermal rating of 500 VA at 30 °C and an accuracy rating of 0.3Y. The PTs shall be ABB type PPM or equivalent. All PTs that are not ABB shall be evaluated by VTES.

8. VTES will provide and install the utility meter, meter enclosure, and cabling from the utility metering compartment to the meter. Contractor is to provide a single 1½ inch conduit from the utility metering compartment to the area where the meter is mounted.
9. The meter location shall be within 30 conduit feet of the metering compartment to facilitate testing.
10. Provisions shall be made for clear wall space to accommodate 48" H × 36" W × 12" D VTES-supplied SCADA and metering equipment. VTES requires a minimum of a 36-inch clear working space in front of the SCADA and metering equipment with a total of 48 inches total depth off the wall.
11. SCADA and metering conduits from the outside primary duct bank and from the medium voltage switch will also terminate at the SCADA and metering cabinet location.

4.7.14.3.6 Additional Service for Temporary Functions

The contractor shall provide and install a service to be used to serve future temporary functions or events outside the building. A 200-amp fused disconnect suitable for use as service equipment, one 2-inch schedule 40 PVC conduit, and service conductors from the transformer's low voltage compartment to the disconnect shall be provided and installed by the contractor. Disconnect shall be rated as NEMA 3R, if located outdoors. Duct from the fused disconnect shall extend outside the building to the manhole nearest the building, and marked "VTES". Disconnect shall be labeled "VTES" and the working voltage shall be identified.

4.7.14.4 Primary Service Standards

For areas where the service will be at primary rated voltage, (12.47 kV), the following will apply for the electric service installation, (chiller plants and other similarly large services where a substation circuit is normally dedicated to the service).

4.7.14.4.1 Manhole and Duct Bank

1. General / A/E Requirements and Contractor Requirements
 - a. The contractor shall provide and install a minimum 8 ft. by 8 ft. by 6½ ft. high (inside dimensions) manhole within 10 feet of the outside of the building, for VTES use only. Refer to the drawing of

a typical manhole layout in the VTES details located in the VT Design Standard Detail Library.

- b. Electrical duct bank shall not be installed under site improvements (stairs, generators, etc.) to the maximum extent practical.
 - c. The contractor will provide and install a concrete encased duct bank from the manhole into the 15 kV switchgear in the building.
 - d. The duct bank will contain at least two 6-inch conduits for primary. They will extend from the manhole to the appropriate compartments of the high voltage switch. Refer to the drawing of a typical duct bank layout in the VTES details located in the VT Design Standard Detail Library.
 - e. The duct bank will also contain one 2-inch conduit for SCADA communications that will extend from the manhole to the meter location and into the SCADA cabinet.
 - f. All ducts shall have pull strings installed. All conduits will be capped, but not glued prior to pouring concrete. All ducts shall have documented mandrel pulls completed prior to installing pull strings.
 - g. Conduits shall be inspected by VTES prior to contractor pouring concrete.
 - h. Any required ESC Plan shall be part of the project documents and in accordance with the VTAS&S and shall be performed by the Contractor. The permitted site shall include the route from the existing primary distribution system to the location of the new service equipment.
2. VTES Requirements
- a. VTES will provide duct bank from the VTES system to the contractor installed manhole outside the building.
 - b. VTES will provide and terminate primary conductors on the high voltage switchgear.
 - c. VTES will also provide and install the utility metering.

4.7.14.4.2 Equipment Room Requirements (Project Responsibility)

General / A/E Requirements and Contractor Requirements

The equipment room shall be provided with the following, and is the responsibility of the project:

1. Ventilation sufficient to maintain a maximum 40 °C temperature on a day with maximum 30 °C outdoor temperature while the transformer is operating at full FA loading with local control at the point of entry.

2. A minimum of one light in the switchgear area shall be on the building emergency circuit.
3. At least one receptacle in the SCADA/meter area shall be on the building emergency circuit. The receptacle shall be labelled to identify the source of power (e.g., PANEL W CBR).
4. Room height shall be at least 2 feet greater than the transformer height and 4 feet greater than the switch height to support jacking and rigging.
5. Provision shall be made for an access path (doors, removable louvers, hallways, etc.) that would be required for the replacement of the switch and transformer. The access path must be wider than the transformer and/or switch (whichever is greater). Do not impede access paths to the equipment. Do not impede door swings. Proper clearance and escape pulls shall be maintained. Consult VTES as needed.
6. Where practical, all medium voltage equipment shall be physically separated (fencing with locking or non-locking gates or equivalent) from low voltage (below 600 volt) equipment per the NEC. At a minimum, yellow caution floor tape floor shall be applied to the floor to identify areas around medium voltage equipment. Warning signs shall be placed to denote this area in addition to the NEC required warning signs on the equipment. If permanent fencing is not installed, temporary fencing shall be provided for use to screen off the area when medium voltage maintenance work is occurring.

4.7.14.4.3 Medium Voltage Switchgear Requirements

A medium voltage circuit breaker shall be used as the service entrance equipment when dual services are required for reliability and maintenance. Typically, three medium voltage circuit breakers in a main-tie-main configuration shall be provided. Manual or automatic operation for transfer between services by these breakers will depend on the needs and requirements of the building. Other options for reliability and maintenance may also be considered by VTES.

The medium voltage circuit breaker shall have the following specifications:

1. Breaker shall have a racking type draw-out mechanism provided with remote racking capability.
2. Auxiliary contacts to indicate the position of each breaker shall be provided. An empty 1-inch conduit from each compartment containing

the terminal connection for the auxiliary contacts shall be extended to the SCADA/meter area and to the SCADA cabinet.

3. All breaker compartments shall have a bonded ground installed in the equipment pad.

4.7.14.4.4 Building Transformer Requirements

VTES will provide the transformer and will be responsible for the primary side of the transformer. The primary side of the transformer will be fully cabled, terminated, and connected by VTES.

Responsibility for the transformer secondary cabling will be split between VTES and the project. VTES will complete the transformer secondary terminations and connections. This work is completed at the transformer only and does not include either the building gear or the building electrical panels.

The secondary cable costs and the secondary cable pull-in shall be the responsibility of the project.

The building transformer(s) will be a cast coil transformer with the following specifications:

1. Applicable Standards: IEEE/ANSI C57.12.01, IEEE/ANSI C57.12.91
2. The transformer shall be UL listed
3. kVA Rating and FA rating shall equal the building service size
4. Frequency: 60 Hz
5. Impedance: 5.75%
6. Windings: Aluminum or copper
7. Primary Voltage: 12.47 kV
8. Primary Taps: two 2.5% FCAN and two 2.5% FCBAN
9. Primary Connection: Delta
10. Secondary Voltage: as needed
11. Secondary Connection: Grounded Wye
12. Application Location: Indoor NEMA 1
13. Sound Level: Standard
14. Winding Temperature Rise: 80 °C
15. Insulation system: 220 °C
16. Primary BIL: 95 kV minimum
17. Secondary BIL: 20 kV minimum
18. Forced Air Rating: AA/FA or AA/FFA
19. Digital three phase temperature monitor for fan control to provide local control and indication of temperatures and alarms with

additional alarm output contacts for connection to utility SCADA system.

20. Surge arrestors: 15 kV distribution class arrestors shall be provided at the transformer high voltage terminals.
21. Provide IEEE/ANSI impulse testing in addition to standard tests.
22. VTES and the VT PM shall be provided with test reports including all standard IEEE/ANSI specified tests, impulse test, and loss evaluation.
23. The transformer pad shall have a ground rod located in the high voltage compartment area.

4.7.14.4.5 Utility Metering and SCADA Requirements

1. General A/E Requirements and Contractor Requirements
 - a. Contractor is to provide 1½-inch conduit from the instrument transformer metering compartment to the area where the meter is mounted.
 - b. The meter location shall be within 30 conduit feet of the metering compartment to facilitate testing.
 - c. Wall space provisions shall be made for a 48" H × 36" W × 12" D cabinet(s) for mounting VTES-supplied SCADA and metering equipment. VTES requires a minimum of 36 inches of clear working space in front of the SCADA and metering equipment as well as 48 inches of total working depth. SCADA cabinet shall be mounted at 80 inches from the top of the cabinet to the finished grade.
 - d. SCADA and metering conduits from the outside duct bank and from the high voltage breakers shall terminate at the SCADA and metering cabinet(s) location.
 - e. All conduit stub-ups shall be plumb and conduit shall be spaced sufficiently to allow installation of couplings and locknuts. All conduits shall be capped, but not glued. Pull strings shall be installed into each conduit.
2. The following shall apply to the metering instrument transformers:
 - a. PTs and CTs shall be provided for utility metering. Provide test reports for these instrument transformers.
 - b. Provide metering accuracy CTs on all three phases. CTs shall have a 5 amp secondary and a primary rating equal to the transformer FA current rating. If this is not a standard CT rating then the next higher standard CT rating shall be used. CT shall have a minimum 0.15B-0.5 accuracy and burden rating. CT leads shall terminate on a shorting type terminal block. The terminal block shall be located in

a compartment that is user accessible without being exposed to primary voltage.

- c. Provide phase to ground metering potentials for all three phases. Metering potentials shall be fused. PTs shall have a ratio of 60:1, a BIL of 95 kV, and a minimum thermal rating of 500 VA at 55 °C including a minimum accuracy rating of 0.3Y.
- d. CTs shall not be used for any other function than VTES metering.
- e. PTs may be used for other functions if those functions are separately fused and do not affect PT accuracy. VTES prefers to not use PTs for other functions. Consult with VTES prior to using.

4.7.14.5 Primary Duct Bank and Manhole Work

1. VTES will provide and install the utility meter, meter enclosure, and cabling from the instrument transformer metering compartment to the meter.
2. VTES will normally install concrete encased primary duct bank at a depth to the top of the duct bank of 30 inches below finished grade. Finished grade must be established before work may commence.
3. The number of cells in the duct bank will vary based on the requirements of the project and considerations of future construction in the area. The minimum number of cells will normally be two 4-inch and one 2-inch conduits.
4. If due to site logistics or other concerns the project team desires that the contractor provides excavation for the primary duct bank facilities, VTES may consider this. VTES would normally perform construction of the duct bank and placement of manholes. In limited selected cases, VTES may elect to have the project install the primary duct bank facilities. If a contract crew other than VTES has been selected to construct a duct bank then VTES must be allowed ample time to review. Specifications from the A/E for the project. Duct banks shall be built to VTES specifications. In addition, a VTES employee(s) will observe and follow the progress of the construction. The A/E shall only use VTES specifications and specified materials for primary duct bank facilities. All materials shall be declared by A/E and approved by VTES prior to construction.
5. VTES will not allow contractors to enter or work on existing duct bank or manholes with energized 12 kV circuits.
6. Manholes provided and installed by VTES for most distribution circuits are 9' × 9' × 7.5' high for outside dimensions (8' × 8' × 6.5', inside

dimensions). For main line 1000 MCM conductors, the manholes are 13' × 9' × 7.5' high outside to allow room for splicing the larger conductors. Smaller manholes will not be approved by VTES for 1000 MCM conductors. In addition, pull pipes must be installed. Consult with VTES as needed.

7. VTES or the project contractor can remove hardscape as specified on the construction documents as necessary in order to install primary duct bank.
8. Replacement of hardscape and landscaping is the responsibility of the project.
9. Any required ESC Plan shall be part of the project documents and in accordance with the VTAS&S and shall be performed by the contractor. The permitted site shall include the route from the existing primary distribution system to the location of the new service equipment.

4.7.14.6 Temporary Construction Service

The contractor is responsible for applying for temporary service at the VTES office at 601 Energy Drive in Blacksburg, VA. The contractor is responsible for all charges for electrical energy consumption used by the temporary facilities. Temporary electric service will be provided by VTES from the nearest facilities with the required capacity. VTES will provide the metering for temporary services. Charges to the contractor for temporary facilities will be actual installation cost and estimated removal cost.

4.7.14.7 Roadway, Parking Lot, and Pedestrian “Hokie” Lighting

4.7.14.7.1 Light Pole and Fixture Installation

1. Contractor Requirements:
 - a. The contractor is responsible for providing and installing the concrete light pole bases and conduit with pull strings interconnecting. See the pole base detail in the VTES details located in the VT Design Standard Detail Library.
 - b. The feeds for the site lighting shall be brought back to the transformer location and terminate in the site lighting flip top enclosures.
2. VTES Requirements:
 - a. VTES provides and installs the poles, fixtures, controllers, and wiring.
 - b. VTES provides labor for termination of wiring.

4.7.14.7.2 Roadway and Parking Lot Lighting Details

1. Roadway and larger parking lots are lighted using 30 foot aluminum poles and a typical cobra head type fixture. New installations use a 70 watt or 140 watt LED cutoff fixture depending upon the project. The 30 foot cobra head lights have a multi-tap ballast (120/208/240/277 volts) or a 480 volt ballast. New installations with LED have a preferred voltage of 208 or 240 volts. The roadway fixture standard arm length is 6 feet, but up to 12 feet can be accommodated. If there is roadway or extensive parking lot lighting, separate metering may be required from the building service.
2. VTES maintains roadway, parking lot, and sidewalk pedestrian lighting. Since lighting on the campus is a safety and security issue and VTES receives after hour calls about lighting outages, any temporary or rerouting of lighting circuits shall be done by VTES. Doing so ensures VTES is aware of the routing and the condition of lighting circuits. Because lighting circuits often extend beyond the project limit, changes to circuits on the project site can affect lighting outside the projects defined boundaries. Coordination between the project, VTES, and the contractor are required for site lighting changes.

4.7.14.7.3 Pedestrian “Hokie” Lights

General / A/E Requirements: “Hokie” pedestrian lights are a 10 foot post-top styled pole. New installations are 50 watt LED lamps. Older Hokie installations are a 100 watt metal halide or high pressure sodium fixture. Typical “Hokie” light spacing along sidewalks is 70 to 80 feet with lights placed at or near intersections. The “Hokie” fixtures are typically installed on 120 volt circuits, but the LED lamps are rated for 120-277 volts. A small step down dry type transformer shall be used if supplied from a 480 volt system. Hokie lights are normally metered as part of the building service.

4.7.14.7.4 Led Lamp Color Rating

1. A 4000 K LED color temperature has been the standard to maintain uniformity across the campus. This matches well with the metal halide lights that are still being used.
2. Exceptions to “Hokie” or cobra head installations must be approved by OUP and VTPD.

4.7.14.7.5 Light Pole and Fixture Demolition

Contractor Requirements: The contractor will remove concrete bases and abandon lighting conduit.

VTES Requirements: VTES will remove the poles and fixtures.

4.7.14.7.6 Site Lighting Power Source Configuration

Consult with VTES for site lighting details.

4.7.14.7.7 Outdoor Transformer Installation

1. Contractor Requirements:
 - a. The contractor is responsible for supplying a NEMA 3R fused disconnect near the lighting controls that serves as the service disconnect for the site lighting, with one 2-inch conduit from the building transformer (or secondary connection cabinet if used) to the disconnect. One 2-inch conduit from the disconnect to the control pedestal shall be installed. Additionally, one 2-inch conduit from the lighting controls pedestal to the first light pole shall be installed.
 - b. All conduit stub-ups shall be plumb and conduit shall be spaced sufficiently to allow installation of couplings and locknuts. All conduits shall be capped, but not glued. All conduits shall have pull strings installed.
2. VTES Requirements:
 - a. VTES provides an outdoor pedestal mounted cabinet (27-inch wide, 18-inch deep, 30-inch tall and 50-inch tall when open) with a separate service from the transformer (or secondary cabinet) for lighting controls.
 - b. VTES shall provide, install, and terminate conductors for this service and provide and install the lighting controls. This allows VTES crews to maintain the lighting without needing access to the building and eliminates VTES's need for building keys.

4.7.14.7.8 Indoor Transformer Installation

1. Contractor Requirements:
 - a. For indoor or below ground vault type transformer installations, the contractor shall provide a photocell lighting controller/contactors in a wall mounted junction box in the vault with a separate service from the transformer.

- b. The photocell shall be exterior mounted, accessible, and shall be provided as well as installed by the contractor. A 1-inch conduit shall be installed from the photocell to the lighting controller.
 - c. The contractor is responsible for supplying a NEMA 3R fused disconnect near the lighting controls that serves as the service disconnect for the site lighting, with one 2-inch conduit from the building transformer, (or secondary connection cabinet if used), to the disconnect. One 2-inch conduit from the disconnect to the control pedestal shall be installed. Additionally, one 2-inch conduit from the lighting controls pedestal to the first light pole shall be installed.
2. VTES Requirements:
VTES shall provide, install, and terminate conductors for this service. This allows VTES crews to maintain the lighting without needing access to the building and limits VTES's need for other building keys.

4.7.14.7.9 General Site Lighting Requirements

1. Minimum conduit size shall be 2-inch schedule 40 PVC from the lighting controls to the first pole in the circuit and 1½-inch schedule 40 PVC for all lighting circuits beyond the first pole. Minimum conduit cover depth is 24 inches under paved areas and 18 inches otherwise. A ⅝" ground rod shall be placed in the concrete base so the ground rod stubs up 5" inside the base of the light. At least one conduit shall be stubbed out of each light base as a spare for future use.
2. See the light base detail in the VTES details located in the VT Design Standard Detail Library.
3. All hardscapes shall have conduits installed for crossing prior to concrete pour.
4. All hardscape and landscaping remediation are the responsibility of the project.

4.7.14.7.10 Lighted Building Sign

The lighted building sign can either be supplied from the building or from the nearest site lighting circuit. If the building is supplied from the site lighting, the sign shall be supplied from the nearest "Hokie" light with a ¾-inch schedule 40 PVC conduit. If the light is an existing "Hokie" light, VTES will remove the pole, drill the concrete base for the ¾-inch conduit, stub out the conduit for contractor extension, and re-install the "Hokie"

pole. VTES prefers lighted building signs to be supplied from the building service panel on a dedicated breaker.

Contractor Requirements: Contractor will extend the ¾-inch conduit from pole base to sign and leave a pull string in the empty conduit.

VTES Requirements: VTES will provide wiring and connect to the site lighting circuit.

4.7.14.8 Utility Manhole and Duct Bank Specifications

4.7.14.8.1 Manholes

1. Furnish and install precast concrete manholes as indicated on the drawings and specified hereinafter. The basis of design shall be equal to the model 880MH as manufactured by Smith Midland of Midland, Virginia. Please note that 1000 MCM cable installations require larger manholes (13' × 9' × 7.5'), see DCSM section 4.7.14.5.
2. Manholes shall have minimum inside dimensions of 8' W × 8' L × 6.5' H. Provide one manhole opening in the top center of the manhole with a diameter of 36". There shall be "knockout" duct windows on all sides to allow for the installation of the duct as detailed on the drawings and for any future installation.
3. Provide manhole reinforced to support highway truck traffic and conform to the Construction Materials Testing Institute Bridge Loading Specification No. H-20. Construction shall also conform to ASTM C857 and C858 pertaining to underground precast concrete utility structures.
4. Each manhole shall be equipped with pulling irons in the bottom near each side wall. Pulling irons shall be seven-strand ½-inch diameter steel rope with yield strength of 2709 kips or equivalent. Exposed portion shall be totally encapsulated in durable non-hydroscopic plastic material.
5. Manhole cover shall say "Electric" and shall be at least 30 inches in diameter, however 36 inches is preferred.
6. Manhole covers and collars for manholes shall be level with the finished grade. Furnish and install precast riser rings between manhole top and manhole cover collar as required for leveling with finished grade. Collars shall be securely fastened to the manhole vault per manufacturer's instructions.

4.7.14.8.2 Manhole Installation

1. Install manholes as indicated in the VTES Details located in the VT Design Standard Detail Library.
2. The hole to receive a manhole shall be dug to the proper depth to receive the manhole and cover plus 8 inches of crushed stone, (21A or 21B), in the bottom of hole. Manholes shall be set in place and inspected prior to backfilling. Stabilize and level the bottom of the manhole excavation with 8 inches of crushed stone. The excavation bottom should be level to within 1 inch side-to-side and end to end. VTES may require re-installation of the manhole vault if the installation is not level.
3. The excavation to receive the manhole shall be a minimum of 6" clear of manhole side in order to allow adequate backfilling and tamping of the earth fill along its side.
4. Place black mastic sealant strips, (provided from manufacturer), in the groove on the top of the wall prior to installing top to provide a water tight installation. VTES will require re-installation if mastic was not used.
5. Cover requirements: Install the manhole at least one foot below finished grade and no more than three feet below finished grade.
6. Install two 6-inch pull pipes into opposing faces of each manhole, per the manhole pull pipe detail in the VTES Details located in the VT Design Standard Detail Library. Coordinate installation with VTES. Install locating beacons in the ends of each pull pipe, under the 6-inch PVC conduit cap and below the surface.

4.7.14.8.3 Duct Bank Conduit and Associated Material

1. All underground conduit runs shall be standard 20-foot length utility Type EB-20 PVC conduit rated for encased burial and shall be encased in concrete. The latest edition of NEMA TC 6 and 8 PVC plastic utilities duct for underground installations standards shall apply. 10-foot lengths are not acceptable.
2. Duct shall be suitable for use with 90 °C rated conductors.
3. Use Schedule 40 PVC where exposed above ground or stubbed up poles.
4. Standard warning tape shall be 4-mil polyethylene 3-inch wide warning tape, red with black letters, imprinted with "CAUTION BURIED ELECTRIC CABLE BELOW".

5. All ducts entering manholes shall be fitted with end bells. Concrete flow through bases and spacers for ducts shall be used.
6. Duct spacers shall maintain a 2-inch separation between ducts and are required every 6½ to 7 feet (three sets per 20-foot length). Duct spacers shall be PVC. The basis of design for duct spacers shall be from GS Industries of Bassett's Underground Products base and intermediate spacer system or VTES approved equivalent are acceptable. Duct spacers shall meet VTES specifications. Otherwise, the duct bank may need to be rebuilt. Consult with VTES as needed.
7. As noted in Duct Bank Installation details, #4 rebar shall be installed (see DCSM section 4.7.14.8.4).

4.7.14.8.4 Duct Bank Installation

1. Work with extreme care near existing ducts, conduits, cables, and other utilities to avoid damaging them.
2. Cut the trenches neatly and uniformly. The walls of the trench may be used to form the side walls of the duct bank provided that the soil is self-supporting and the concrete envelope can be poured without soil inclusions. Forms are required where the soil is not self-supporting or in areas that have been dug wider than the normal trench.
3. Required depth of conduit from final grade to the top of the conduit in the conduit bank is 36" for primary, minimum. Less cover requires VTES review.
4. Provide one #4 rebar running longitudinal with the duct bank in each top and bottom corner approximately 3 inches from the edge of the concrete envelope. Provide one additional #4 rebar in the bottom for each additional foot of duct bank width over 1.5 feet. Additional rebar is to be evenly spaced across the width of the duct bank. Secure rebar with tie wire at every duct spacer. Rebar lengths shall overlap 2 feet minimum at the ends of the rebar (joints).
5. Reinforcing bars shall be used to stabilize the duct and spacers when the concrete is poured. These prevent the duct bank from "floating" up in the concrete. Drive #4 reinforcing bars through the inside edges of the duct spacers and at least 6 inches into the trench bottom, securing with tie wire. The top row of conduit shall be secured to the duct spacers with tie wire or a #4 rebar across the top shall be added and secured to the side stabilizing rebar with tie wire.
6. All bends shall be long sweep. The preference is to "bow" the conduit in long sweeps instead of installing conduit bend fittings. Where

fittings or heated bending of conduit are required, the minimum radius shall be 60 inches. Maximum total bends per run between manholes and pads shall be the equivalent of three bends at 90 degrees. As-built drawings shall show the size and location of any fittings or heated bends used. VTES must approve all drawings prior to construction.

7. Couple the ducts with proper PVC couplings. All couplings shall be glued prior to concrete encasement.
8. Unless indicated otherwise on the drawings, all conduit shall enter manholes at a 90 degree angle. Conduit shall enter the manhole window on the outermost sides of the window, (not in the middle). Conduits shall enter at the bottom windows of the manhole unless noted otherwise on the attached drawings.
9. Conduit runs that continue straight through a manhole shall enter and exit directly opposite each other, (no elevation or lateral changes), unless indicated otherwise on the drawings. Conduit runs that turn 90 degrees through the manhole shall be arranged so conduits enter and exit on diagonally opposite corners rather than the near corners. This facilitates pulling and racking of cable.
10. Concrete encasement: Provide a minimum of 3 inches of concrete on top and 3 inches on each side of duct in the duct bank. Vibration of the concrete during pouring will be required to ensure encapsulation of all the duct in the duct bank. Concrete shall be 4000 psi.
11. Refer to the typical duct bank detail in the VTES details located in the VT Design Standard Detail Library for a typical 15 kV duct bank installation and concrete encasement requirements.
12. After the concrete encased duct has sufficiently cured, the trench shall be backfilled and compacted to grade with earth. The standard warning tape shall be installed 12 inches above the duct bank during the backfilling. Contractor shall notify the VT PM and VT GIS for survey of installed duct bank.
13. Keep ducts clean of earth, sand, or gravel during construction, and seal with tapered plugs upon completion of each portion of the work.
14. Upon completion of the conduit installation or installation of direct buried ducts, a standard flexible mandrel shall be pulled through each duct to loosen particles of earth, sand, or foreign material left in the line. The mandrel shall not be less than 6 inches long, and shall have a diameter of no less than ½-inch less than the inside diameter of the

duct. Mandrel pulls shall be witnessed by VTES, prior to pouring concrete.

15. After the mandrel pull, a pull rope shall be installed in each conduit. It shall be plastic with 200-pound minimum tensile strength.
16. Duct and Conduit capping: Cap the ducts and conduits at building entrances, and at outdoor terminations for equipment, with a suitable preformed conduit cap to prevent the entrance of dirt and contaminants.
17. Connections to Existing Manholes: Due to energized conductors, the contractor shall not enter existing manholes. Stop the duct bank 20 feet outside the existing manhole leaving 2 feet of duct and rebar exposed (not concreted) and cap/plug the ducts.
18. VTES will connect the duct bank to existing manholes. When VTES has completed the duct bank connection, the contractor shall complete the concrete encasement of duct bank.
19. Partially Completed Duct Banks: During construction, wherever a construction joint is necessary in a duct bank, prevent debris such as mud and dirt from entering ducts by providing suitable conduit plugs. Fit concrete envelope of a partially completed duct bank with reinforcing steel extending a minimum of 2 feet back into the envelope and a minimum of 2 feet beyond the end of the envelope.
20. VTES shall specify the number, size, and configuration of ducts.
21. A VTES representative shall be present during the duct bank installation to inspect and review the quality of the installation. If poor workmanship is identified during duct bank installation, the VTES representative will notify the VT PM and the UBO, either of whom has the authority to stop work. The duct bank deficiency will be corrected before normal installation continues. Duct bank of deficient quality shall not be accepted and will be rebuilt.

4.7.14.9 Primary Relocation Work

Relocation of Primary Conductors:

1. VTES will perform any relocation of primary duct bank or other primary facilities required by the project. Requirements will be handled on a case-by-case basis and will be based upon VTES specifications. Consult with VTES as needed.
2. Routing or locations must be coordinated with VTES, OUP, and CC. The proposed layout shall be provided to VTES for development of any duct bank and pad requirements.

3. Any required ESC Plan shall be part of the project documents and in accordance with the VTAS&S and shall be the responsibility of the project.
4. Any hardscape or landscaping repair is the responsibility of the project.
5. A finished grade must be established prior to starting the project.

4.8 TRANSPORTATION

VDOT standards shall be followed for all road and trail design and construction. Projects shall use guidance from the Virginia Tech Parking and Transportation Master Plan and Appendix H: Transportation & Parking Project Review Checklist. All transportation signage shall follow VT Wayfinding Standards, VDOT, and the FHWA Manual on Uniform Traffic Control Devices (MUTCD).

All transportation routes shall be designed for the largest vehicles expected to access the site via that route.

The proposed curb radii shall be large enough for all traffic including tractor trailers, transit, and emergency vehicles. Turning movements and paths of the largest vehicle shall be shown on plans.

Designer and Contractor shall ensure smooth transition between all proposed and existing grades, to include asphalt, landscaping, concrete, etc.

In general, fire truck turning movements should follow the standard in the Transportation Details located in the VT Design Standard Detail Library.

4.8.1 Transportation Construction and Equipment – Vehicle Barriers

When roadway guardrail is needed, timber wooden guardrail should be used equal to Blue Ridge Parkway type; see the standard in the VT Design Standard Detail Library.

4.8.2 Alternative Transportation Items

The need for and quantity of bike racks, bike shelters, and bike hubs shall follow the DCSM and the VT Bicycle Parking Master Plan. Location of bike racks shall be reviewed and approved by VT.

4.8.3 Crosswalks

1. Crosswalks shall use “continental” style pavement markings and cross roads perpendicular to the vehicle traffic flow.
2. Crosswalks shall use the following lighting specifications:
 - a. The basis of design for the pole shall be HAPCO part no: HAP30971P30 – 20' Decorative Alum Pole Hokie Brown w/ 8' Single Arm for Over Head

Tear Drop Fixture. See the crosswalk light standard in the VT Design Standard Detail Library.

- b. The basis of design for the luminaire shall be HAPCO part no: HAP80911P30 – Adjustable Luminaire Adapter for Antiques Lighting SB33 Fixture. See the crosswalk light standard in the VT Design Standard Detail Library.
3. In general, crosswalks shall follow the standard in the Transportation Details located in the VT Design Standard Detail Library.
4. Detectable warning surfaces (truncated domes) shall follow the standard in the Transportation Details located in the VT Design Standard Detail Library.
5. All crosswalk slopes shall meet ADA standards.

4.8.4 Site Work Exterior Improvements – Road Crosswalks Pavement Markings

1. Road crosswalks should follow VDOT and MUTCD standards, more specifically the continental style crosswalk.
2. The width of the crosswalk thermoplastic should be at least 6 feet wide, wider in high pedestrian volume areas.
3. All trail design and construction should follow American Association of State Highway and Transportation Officials (AASHTO) standards.
4. Trail width is 10-foot paved width with 3-foot grass shoulders.
5. All plans are to be reviewed by OUP.

4.8.5 Vehicular Access and Parking

4.8.5.1 Traffic Signage

1. All exterior signage that is intended for traffic control should meet VDOT standards and follow Appendix F: Campus Wayfinding Guidelines.
2. All signs related to transportation are to be approved by the Virginia Tech Transportation Planning Engineer.
3. All exterior signage should follow Appendix F: Campus Wayfinding Guidelines where applicable.
4. All exterior signage should follow Appendix F: Campus Wayfinding Guidelines materials standards and mounting methods to insure proper maintenance.
5. All parking signage should be purchased through the Virginia Tech Sign Shop.
6. The transportation and parking checklist is a guide for the A/E to use to ensure common problems are addressed. See Appendix H: Transportation

& Parking Project Review Checklist. The transportation and parking checklist is a guide for the A/E to use to ensure common problems are addressed.

All transportation signage shall follow the requirements from Appendix F: Campus Wayfinding Guidelines, VDOT, and MUTCD. In general, ADA Parking Signs should follow the standard in the Transportation Details located in the VT Design Standard Detail Library.

4.8.5.2 General Parking Requirements

Parking Requirements: Parking on the Virginia Tech campus in Blacksburg is regulated for all vehicles. Virginia Tech Parking Services strictly enforce parking regulations (regulations at: www.parking.vt.edu). Violations of parking regulations could result in parking tickets, wheel booting, or vehicle towing.

Loss of existing parking spaces shall be minimized. Total number of parking spaces lost shall be shown on plans at each plan review stage. Reduction of parking spaces shall be incorporated into the project budget. Replacement parking will be billed to the project. There will be no charge for parking spaces restored at the conclusion of the project.

1. Parking spaces shall be delineated by 4-inch striping.
2. All parking spaces shall be 8.5' × 18'.
3. Striped out areas next to ADA parking shall be 8.5' × 18'.
4. Parallel ADA spaces shall be avoided if possible.
5. Parking lot curbing shall be VDOT standards.
6. Service vehicle parking spaces shall be included. Project specific requirements shall be coordinated with Parking Services via the VT PM.
7. In general, typical parking spaces should follow the standard in the Transportation Details located in the VT Design Standard Detail Library.
8. In general, parking wheel stops should follow the standard in the Transportation Details located in the VT Design Standard Detail Library.
9. In general, bike parking should follow the VT Bicycle Parking Master Plan and the standard in the Transportation Details located in the VT Design Standard Detail Library.

4.8.5.3 Minimum Standards for Parking

The following minimum parking space dimensions and minimum numbers of spaces are standards for use in the design of state parking decks, parking garages and parking lots. Parking configurations and aisles widths shall be

designed to provide adequate maneuvering and safe circulation for all vehicles. Consideration shall be given to increasing the sizes of spaces and aisles for short duration parking and/or high turnover rates. Protection of columns, walls and posts with parking signage shall be considered by the use of wheel stops, bollards, or guard rails of contrasting color.

1. Stalls in Parking Decks, Parking Lots, and Garages Utilizing Self-Parking:
 - a. For standard cars, maintain a minimum width of 8'6", a minimum length of 18', and a minimum area of 153 sq. ft.
 - b. For accessible spaces, refer to the ADA Standards for Accessible Design, latest edition. Locate the accessible parking spaces to minimize the distance to accessible exits, routes to accessible buildings, and exposure to crossing traffic.
2. Parking Space Planning and Minimum Number of Spaces:

This policy applies to all new buildings, additions and changes in use or occupancy. Buildings which undergo major renovations shall comply to the greatest extent possible.

All projects that renovate or alter accessible facilities shall provide an adequate number of parking spaces for physically disabled people. An adequate number of parking spaces means a number of accessible spaces that complies with the ADA Standards for Accessible Design, latest edition. These parking spaces shall be located closest to the nearest accessible entrance on an accessible route and no more than 250 feet from the accessible entrance.

Parking plans may be developed for an entire campus, facility or complex which addresses the total parking spaces available for all buildings and their associated use groups. Where insufficient parking is provided on site, the parking plan shall address the availability of offsite parking for the occupants and guests to the building or facility.

For purposes of calculating employees/students, their number is equal to the number of workstations or the maximum number of employees/students in a shift. For mixed use occupancies, the total number of parking spaces shall be allocated proportionally to the individual groups which the parking lot or structure is intended to serve.

4.9 SITE GRADING

1. The Contractor shall bring the site to final grade and full stabilization to comply with the VTAS&S.

2. Prior to grading, topsoil should be stripped and stockpiled for reuse where feasible.
3. Slopes designated as mowable lawn may not exceed 3:1 slope.
4. Planted areas shall have a maximum slope of 2:1 with approved soil holding landscape material.
5. Paved areas should be graded to positively drain (1% min. for concrete and asphalt, 2% for unit pavers and other materials) but within the specifications outlined in the ADA standards.
6. Lawns should be graded to minimum slope of 2% to achieve positive drainage.
7. Grading for project should seek to balance cut and fill on-site.

CHAPTER 5 - BUILDING

5.1 ENERGY EFFICIENT DESIGN

The A/E shall use ASHRAE Standard 90.1 and this section for energy efficient design.

5.1.1 Energy Metering

5.1.1.1 Electricity (Digital Energy Meters)

1. Application: Substations and building primary switchgear shall have power quality meters. Building submeters shall have energy meters. All meters shall have a local display of demand and totalized consumption.
2. Connectivity: All installations shall be digitally integrated into the Building Automation System (BAS) via MODBUS/IP or BACNet/IP protocols or be directly accessible over the University Ethernet for energy management use. At a minimum, apparent power, reactive power, real power, and energy shall be mapped to the BAS/Data Management system. Consumption reading in the BAS/Data Management shall match the meter's local display.

The contractor shall be responsible for proper installation of the meter and for enabling energy consumption calculations during construction before the service is turned on. Temporary meters for construction use will be supplied by the VTES metering department without connection to the BAS and will be read monthly.

3. Approved Meters:
 - a. Power Quality Meters:
 - i. Square D CM4000, PM870, or equivalent
 - ii. ION 7650/7550 series
 - iii. GE PQM II series
 - b. The basis of design for energy meters shall be:
 - i. Square D energy meter or equivalent
 - ii. ION 6200 series

5.1.1.2 Chilled Water and Heating Hot Water

1. Application
 - a. Transit-time ultrasonic flow meters may be used on all pipe types and shall be used for services greater than 6 inches. Services at or below 6 inches may use Teflon-lined magnetic flow meters. A calibrated pair

of temperature sensors for energy meters shall be installed in thermo wells on the chilled water supply and return line.

- b. If meters are installed in the mechanical rooms, they shall have a converter and a local display mounted in the same room. When meters are installed on the lines in the tunnels or crawl spaces which are not easily accessible, these meters shall have a remote converter mounted in the nearest mechanical room. The manufacturer's specification must be met for maximum allowable distances between the sensor (meter) and the convertor.
 - c. For existing buildings, meter technology and size selection shall be based upon actual volumetric flow rate in the pipes, the allowed permanent pressure loss, and the "minimum straight run" availability. Minimum and maximum flows in the pipes shall be estimated using the design cooling load data, pump curves or field measurements.
 - d. For new construction, design documentation and meter submittal package shall include tabulated values of the min/max flow in the line and the allowed maximum pressure drop across the meter.
 - e. Ultrasound flow meters shall have 15 unobstructed pipe diameters of straight pipe upstream and 5 pipe diameters downstream unless specified otherwise by the manufacturer.
 - f. All meters shall provide a Turndown Ratio of 50:1 or more.
 - g. All meters shall provide an accuracy of 1.0% or less for the whole range of volumetric flows supported by the meter.
 - h. All meters shall have ability to measure the volumetric flow rate and calculate instantaneous and totalized cooling demand.
2. Connectivity
- a. All installations shall be digitally integrated into the BAS via MODBUS/IP or BACNet/IP protocols or be directly accessible over the University Ethernet. Totalization, flow and Btu rates, and diagnostic data shall be mapped into the BAS or a Data Management Platform. Meters shall calculate and display energy consumption without BAS/Data Management support. Totalization values in the BAS/Data Management shall match the meter's local display.
 - b. The Contractor shall coordinate with the Commissioning Authority and shall be responsible for proper installation of the meter and for enabling energy consumption calculations during construction before the service is turned on, unless instructed otherwise. The Office of Energy Management will estimate consumption during construction

using design maximum values when the utility is in service and meter data is not available.

3. Approved Meters:
 - a. Ultrasonic flow/energy meters:
 - i. Flexim FLUXUS series
 - ii. Siemens SITRANS FUS series
 - iii. Spire TP series
 - iv. Dynasonics TFX series clamp-on (for < 2" CHW services)
 - b. Magnetic flow meters:
 - i. Toshiba LF-series
 - ii. Johnson-Yokogawa ADMAG series
 - iii. Siemens SITRANS FM series

5.1.1.3 High Pressure Steam

1. Application
 - a. Meters shall be spring-loaded, variable area type for applications up to 12 inches. For service sizes greater than 12 inches, in-line or insertion vortex shedding meters shall be used. In general, all meters shall have at least 15 unobstructed pipe diameters of straight pipe upstream and 5 pipe diameters downstream of meter installation unless recommended otherwise by the manufacturer.
 - b. Ceramic-lined electromagnetic flow meters shall be installed for steam condensate and must be approved by the metering department when a steam flow meter cannot be installed. Condensate meters shall have ability to measure the flow in both directions.
 - c. If meters are installed in the mechanical rooms, they shall have a converter and a local display mounted in the same room. When meters are installed the tunnels or crawl spaces which are not easily accessible or when the environment in the said locations is harsh, these meters shall have a remote electronics located in the nearest mechanical room. The manufacturer's specification must be met for a maximum allowable distance between the sensor (meter) and the convertor.
 - d. For existing buildings, meter technology and size selection shall be based upon the actual steam load in the building and the properties of steam. The following parameters have to be estimated or measured for every location prior to meter selection:
 - i. Steam quality (saturated vs superheated)
 - ii. Steam pressure (psig)

- iii. Steam temperature (°F)
 - iv. Steam volumetric flow Min and Max (cu. ft./sec.)
 - v. Steam velocity Min and Max (ft./sec.)
 - vi. Turndown Ratio = V_{\max} / V_{\min}
- e. For new construction, engineering design documentation and meter submittal package shall include tabulated values for the above parameters and the maximum allowed pressure loss.
 - f. In the instances when there is a need to install a meter of smaller diameter compared to the diameter of the line, the section of the pipe of a required length shall be downsized using two eccentric reducers to avoid condensate accumulation in the pipe.
 - g. In the instances when minimum straight pipe run requirements are not met, an upstream flow straighteners shall be utilized.
 - h. All meters shall have ability to calculate the instantaneous and totalized volumetric, mass and Btu flow rate of steam.
 - i. All meters shall provide a Turndown Ratio of 50:1 or more.
 - j. All meters shall provide an accuracy of 1.0% or less for the whole range of volumetric flows supported by the meter
2. Connectivity
- a. All installations shall be digitally integrated into the BAS via MODBUS/IP or BACNet/IP protocols or be directly accessible over the University Ethernet. Totalization, flow and Btu rates, and diagnostic data shall be mapped into the BAS or a Data Management Platform. Steam meters shall calculate and display energy or mass flow rate demand and total consumption without BAS/Data Management support. Condensate meters shall calculate and display volumetric flow demand and consumption.
 - b. The contractor shall be responsible for proper installation of the meter and for enabling energy consumption calculations during construction before the service is turned on, unless ordered by the Director of Utilities. The Utilities department will estimate consumption during construction using design maximum values when the utility is in service and meter data is not available.
3. Approved Meters
- a. Spring-loaded variable area meters: Spirax-Sarco Gilflo, ILVA, or DIVA series
 - b. Vortex meters (Insertion and Inline):
 - i. EMCO Vortex-PhD series
 - ii. Spirax-Sarco V-Bar series

- iii. Spirax-Sarco VLM10 series
 - iv. VorTek PRO-V series
 - v. Sierra Instruments Innova-Flo series
- c. Magnetic meters for condensate flow measurements:
 - i. Toshiba LF-series
 - ii. Johnson-Yokogawa ADMAG series
 - iii. Siemens SITRANS FM series
- d. The basis of design for flow computers shall be:
 - i. Spirax-Sarco M800 series
 - ii. KEP SuperTROL series

5.1.1.4 Low Pressure Steam

1. Application
 - a. Care shall be exercised while selecting meters for Low Pressure steam applications. Steam meters shall be selected in the way to avoid excessive permanent pressure loss across the meter which is accomplished by selecting meters with low minimum velocity requirement. The permanent pressure drop across the meter shall not exceed 1 psi at the design flow conditions.
 - b. Transient time ultrasonic and turbine style meters may be utilized for LP steam measurement applications. In general, all meters shall have at least 15 unobstructed pipe diameters of straight pipe upstream and 5 pipe diameters downstream of meter installation unless recommended otherwise by the manufacturer.
 - c. Ceramic-lined electromagnetic flow meters shall be installed for steam condensate and must be approved by the metering department when a steam flow meter cannot be installed. Condensate meters shall have ability to measure the flow in both directions.
 - d. If meters are installed in the mechanical rooms, they shall have a converter and a local display mounted in the same room. When meters are installed the tunnels or crawl spaces which are not easily accessible or when the environment in the said locations is harsh, these meters shall have a remote electronics located in the nearest mechanical room. Manufacturers' specification must be met for a maximum allowable distance between the sensor (meter) and the convertor.
 - e. For existing buildings, meter technology and size selection shall be based upon the actual steam load in the building and the properties

of steam. The following parameters have to be estimated or measured for every location prior to meter selection:

- i. Steam quality (saturated vs superheated)
 - ii. Steam pressure (psig)
 - iii. Steam temperature (°F)
 - iv. Steam volumetric flow Min and Max (cu. ft./sec.)
 - v. Steam velocity Min and Max (ft./sec.)
 - vi. Turndown Ratio = V_{\max} / V_{\min}
- f. For new construction, engineering design documentation and meter submittal package shall include tabulated values for the above parameters and the maximum allowed pressure loss.
 - g. In the instances when there is a need to install a meter of smaller diameter compared to the diameter of the line, the section of the pipe of a required length shall be downsized using two eccentric reducers to avoid condensate accumulation in the pipe.
 - h. In the instances when minimum straight pipe run requirements are not met, an upstream flow straighteners shall be utilized
 - i. All meters shall have ability to calculate the instantaneous and totalized volumetric, mass, and Btu flow rate of steam.
 - j. All meters shall provide a turndown ratio of 30:1 or more.
 - k. All meters shall provide an accuracy of 1.0% or less for the whole range of volumetric flows supported by the meter
2. Connectivity
- a. All installations shall be digitally integrated into the BAS via MODBUS/IP or BACNet/IP protocols or be directly accessible over the University Ethernet. Totalization, flow and Btu rates, and diagnostic data shall be mapped into the BAS or a Data Management Platform. Steam meters shall calculate and display energy or mass flow rate demand and total consumption without BAS/Data Management support. Condensate meters shall calculate and display volumetric flow demand and consumption.
 - b. The contractor shall be responsible for proper installation of the meter and for enabling energy consumption calculations during construction before the service is turned on, unless ordered by the Director of Utilities. The Utilities department will estimate consumption during construction using design maximum values when the utility is in service and meter data is not available.

3. Approved Meters
 - a. The basis of design for transient time ultrasonic insertion meters shall be GE Panametrics GS868 series
 - b. The basis of design for insertion style turbine meters shall be:
 - i. Spirax-Sarco RIM 20
 - ii. VorTek Turbo Pro-T series
 - c. Magnetic meters for condensate flow measurements:
 - i. Toshiba LF-series
 - ii. Johnson-Yokogawa ADMAG series
 - iii. Siemens SITRANS FM series
 - d. The basis of design for flow computers shall be:
 - i. Spirax-Sarco M800 series
 - ii. KEP SuperTROL series

5.2 THERMAL AND MOISTURE PROTECTION DESIGN STANDARDS

5.2.1 Waterproofing and Drainage for Subsurface Structures

No state buildings for human or equipment occupancy shall be designed with building systems (such as ductwork) or basement floor levels below the water table. Varying degrees of subsurface water content require the following minimum waterproofing and drainage techniques.

5.2.2 Soils with Little or No Obvious Water Content

1. Waterproof walls and provide any suitable waterproofing protection board.
2. Provide perforated type drainage pipe with gravel surrounding.
3. Backfill with suitable material that has some porosity.

5.2.3 Damp to Wet Soils with No Obvious Water Source

1. Waterproof walls and provide protection board. Note: If geotechnical type drainage board is used, protection board may not be required.
2. Provide perforated type drainage pipe and (if necessary) surround with full height gravel to the underside of the impervious soil or material. An approved geotechnical type drainage board may be used in lieu of the full height gravel at the contractor's option.
3. Provide impervious soil or material at finish grade.

5.2.4 Walls or Floors Below the Groundwater Table

Delete the lowest floor or space below the highest calculated groundwater table possible, or raise the level of the lowest top of floor structure above the top of

the highest calculated groundwater table possible, and follow the waterproofing techniques listed above.

5.3 CONCRETE

1. All exposed vertical concrete edges are to be ¾" chamfered and ½" round over flatwork.
2. All control joints shall be sawcut.
3. LEED documentation shall be included in the shop drawing submission as required by LEED approach for project.
4. Reinforcing bars shall be placed at re-entrant corners, slab penetrations, and embedded assemblies to restrain concrete cracking.
5. Slab-on-grade floors in buildings shall have a minimum thickness of 4 inches.
6. Hardener treatment is required for all interior floors subject to heavy, impact, and/or rolling loads.
7. A sealer is required for all interior floors. Verify sealers, hardeners, and additives are compatible with curing and finish floor requirements.
8. Slip resistant surfacing (having a DCOF of 0.42 or better) shall be specified for all ramps, stair treads, and landings when not covered with flooring materials. The method and details of providing a slip resistant surface shall be indicated in the construction documents (e.g., broom finish, exposed aggregate, or coating).
9. Building interior concrete surfaces to be painted shall not receive a rubbed finish.
10. All defects, form irregularities or honeycomb shall be repaired immediately upon form removal.
11. Anything attached to flatwork must be epoxy-anchored. Mechanical anchors are not acceptable. The intent is to prevent concrete from cracking due to water getting into perimeter of the fastener holes. This is for fasteners that are not loaded in tension.
12. Epoxy anchors shall not be used for overhead installations or members that are loaded in constant tension.

5.3.1 Architectural Concrete

The OUP shall be consulted on the selection of all exterior materials, including precast architectural concrete.

1. Architectural precast concrete is specified under this section for color consistency of the exposed exterior surfaces. The architectural precast concrete design mix produced by the following manufacturer is to establish an "or equal" design standard and not a required proprietary product.

2. The color produced by the following mix design is to be the standard precast color and finish for new construction unless otherwise noted by OUP.
3. OUP may require a different color/finish if a match of existing precast concrete, cast stone, or limestone is to be part of the work, such as for an addition to an existing building.
4. Submittals: Prior to construction of the project mock-up wall, submit 12" × 12" architectural precast concrete sample(s) for preliminary color and finish design approval by OUP. The approved sample will be the basis for the color and finish of the precast sample(s) to be installed in the mock-up wall.
5. The basis of design for architectural precast concrete shall be:
 - a. Manufacturer: American Stone, Virginia LLC, Ladysmith, Virginia
 - b. Mix Design based on sample #3168A (exact proportions are subject to adjustment to obtain color and finish):

REFERENCE	MATERIAL	SOURCE	QUANTITY (lb./cu. yd.)
ASTM C33	Texas #7 Gravel	Lafarge	1678
ASTM C33	Texas C33 Sand	Lafarge	1570
ASTM C150	White Cement	Federal	658
ASTM C979-82	Yellow 50908 Pigment	Davis	10
ASTM C494	Sika 4100 water reducer	Sika	39 oz. +/-
ASTM C260	Sika AEA-14 air entrainment	Sika	5% +/- 1.5%
POTABLE	Water		263 +/-

- c. As an alternative to using the above referenced mix design supplier may match a physical precast sample provided by OUP.

5.4 EXTERIOR ENCLOSURE

The OUP shall be consulted on the selection of all exterior materials, including synthetic wood paneling. This also includes structures not attached to buildings (e.g., handrails).

The OUP shall be consulted on the selection of all exterior materials. When metals are used, zinc is the preferred material.

The use of metal panel in mechanical screening shall include articulation and refinement to break down scale.

5.4.1 Exterior Walls

5.4.1.1 Fire Walls: Abutting New Construction to Existing Structures

When an addition is needed adjacent to an existing state-owned building, and the existing building cannot accommodate the additional height and area limitations due to its construction type and use group, as an alternative to a traditional fire wall, Chapter 7 of the VCC now recognizes that two exterior building walls may be designed to function as a “double fire wall,” as defined in NFPA 221. Consideration shall be given to the structural stability and fire resistance of the exterior walls and door openings. Where door openings are provided, portals or vestibules designed to comply with NFPA 221 are acceptable.

5.4.1.2 NFPA 285 Acceptance Criteria in Exterior Walls

For the use of Exception No. 3 to section 2603.5.5 in the 2015 edition of the VCC, contact the UBO.

5.4.1.3 Intersection of Fire Resistance Rated Wall Assemblies with Lesser-Rated and Non-Rated Wall Assemblies

The 2015 VCC provides limited guidance for addressing how Fire Barriers (VCC 707), Fire Partitions (VCC 708), and Smoke Barriers (VCC 709) intersect with lesser-rated and non-rated exterior walls. At these conditions, the UBO applies and enforces the following requirements:

1. The gypsum board manufacturer(s) included in the listed fire resistance rated wall assemblies typically provide partition priority legends and installation details to address these conditions as well as instructions on how corners and tees are to be constructed. The UBO considers the manufacturer’s installation instructions to be a critical component for achieving a compliant fire resistance rated fire barrier, fire partition, or smoke barrier assembly. To the extent possible, the manufacturer's instructions shall be incorporated into the Working Drawings.
2. The VCC sections for fire barriers, fire partitions, and smoke barriers do not require the exterior walls of the separated fire compartments to be fire resistance rated. The rationale for this is based on fire exposure from outside of the building (not within the building). As a result, these sections do not adequately address the potential for in-building horizontal fire spread from one fire compartment to another where the interior wall assembly intersects with the exterior wall. The UBO applies

the following requirement to address this concern: where the fire barrier, fire partition, or smoke barrier assembly intersects and terminates at a lesser-rated or non-rated exterior stud wall, the assembly shall extend in its entirety to the inside face of the exterior wall sheathing.

3. As an alternative, VCC section 707.9 Voids at Intersections or 715.4.2 Exterior Curtain Wall/Vertical Fire Barrier Intersections may be applied, whereby the fire resistance rated wall assembly terminates at the interior wall sheathing of the exterior wall. In this arrangement, the intersecting stud cavities within the exterior wall shall be completely filled with an approved material, such as mineral wool. Conditions may vary from project to project, so consult with the UBO to determine the correct application of this alternate approach.

The following documentation for the design of fire resistance rated wall assemblies shall be provided at a minimum: 1) define the listed fire resistance rated wall assembly, 2) define the respective listed head-of-wall and bottom-of-wall joint systems, 3) provide the 'basis of design' gypsum board manufacturer's partition priority legend and related standard details for the proposed construction, and 4) include copies of the listings for the proposed fire resistance rated wall assemblies and joint systems in their entirety on the Working Drawings (see DCSM section 2.7.7.15.1).

5.4.1.4 Masonry/Hokie Stone

The OUP shall be consulted on the selection of all exterior materials. Unit masonry (e.g., brick, concrete masonry units, or faux stone) is typically not an acceptable exterior cladding material, in-particular for the campus core.

The OUP shall be consulted on all applications of Hokie Stone. In addition to the traditional Hokie Stone veneer, this includes all non-standard uses such as grade-b stone or polished stone.

1. Hokie Stone shall not be used for any horizontal surfaces.
2. Granite and slate shall not be used for pedestrian surfaces.
3. Weep holes shall be cellular vent type similar to Heckman No. 85.
4. Guide specifications for the use of Hokie Stone materials, applications, installation, execution, and accessories, refer to Appendix G: Hokie Stone Masonry Guide Specifications.

5.4.1.5 Wall Details

1. All parapet walls up to a 4'-0" height above roofing shall be flashed continuous from coping to roofing.
2. Fiberglass batt insulation shall be installed in such a manner as to eliminate exposed fiberglass in areas needing to be accessed for inspections and/or maintenance. Designs shall encapsulate fiberglass using foil or pre-applied backing, plastic, or gypsum board covering. Open-facing insulation is not allowed.
3. Fire caulking shall be from an approved manufacturer. Approved manufacturers include:
 - a. Hilti, Inc.
 - b. 3M Fire Protection Products
 - c. Dow
4. Exterior joint sealant in building elements shall be a silicon product. Approved manufacturers include:
 - a. Henry
 - b. Grace
 - c. Meadows
5. All through wall flashing shall be 16-ounce minimum copper or stainless steel. If stainless steel flashing is used, it shall be Type 304 Stainless Steel, meeting the requirements of ASTM A666, and shall be minimum of 0.018 inch (0.4572 mm) thick. Other metal or vinyl flashing shall not be used. All coping flashing shall be through wall type.
6. All flashing corners shall be pre-fabricated, or field fabricated with welded or soldered seams.
7. All vapor barriers shall be applied and protected per manufacturer's instructions.

5.4.2 Exterior Windows

1. OUP shall be consulted on all openings. These include, but are not limited to:
 - a. Windows for punched openings (especially in historic, legacy, or contributing-legacy buildings as identified in the campus master plan) – Use one of the thermally-broken windows selected by OUP as a basis of design.
 - b. Stick-built fenestration systems – Generally not an acceptable exterior fenestration system, especially for the campus core and at historic, legacy, or contributing-legacy structures.

2. Exterior glazing shall be insulating glass units meeting the following characteristics and performance criteria:
 - a. Passive Solar Low-E Insulating-Glass Units with Argon gas interspace content.
 - b. Outdoor lite and indoor lite shall be Class 1 (clear) float glass, annealed of Kind FT (fully tempered) as specified.
 - c. Low-E coating shall be pyrolytic on the second and third surface.
 - d. Visible Light Transmittance shall be 37 percent minimum.
 - e. Winter Nighttime U-Factor shall be 0.38 maximum.
 - f. Solar Heat gain Coefficient shall be 0.55 maximum.
3. Metal windows and storefront shall have thermal break frames and insulating glass.
4. Operable Sash: Unless impractical, it is recommended that operable windows be provided in areas that can create effective cross ventilation in the building if required due to failure of HVAC system. Operable sashes shall be provided with lockable operators. Operable windows in residence halls shall have window screens and first floor windows shall have safety screens.

5.4.3 Architectural Woodwork

Wood stairways, treads, nosings, and railings are acceptable.

5.5 ROOFING

5.5.1 Roofing Policy and Technical Standards

The provisions of this section shall govern the design of low-slope (roof slope less than 2:12), flexible membrane (built-up and single-ply) roofs. This section also governs the design of metal roofing systems to be used on University buildings.

This section provides criteria and qualifications for selecting full-time Roof Inspectors (DCSM section 8.3.4) and Roof Consultants/Inspection Services Providers (DCSM section 8.3.5). It also provides criteria for non-destructive evaluation (NDE) roofing surveys and criteria for drawings to accompany NDE surveys (DCSM section 5.5.3).

New or reroofing project working drawings and specifications shall be prepared by a licensed Virginia A/E. Procurement of these professional services is covered in the VT CPSM.

Assuming roofs are equal in other respects, low-slope roofs that shed water are more desirable than flat roofs that do not; and steep roofs are more desirable

than low-slope roofs. Economy, aesthetics, constructability and compatibility are valid considerations in evaluation and design of roof systems.

The A/E shall include form DGS-30-326, "Special Requirements for Low Slope Roofing Membranes," in the front end of the specifications and reference it in the low slope roofing membrane specifications. The A/E is responsible for selection and specification of the roofing membrane.

5.5.2 General

OUP shall be consulted on all roofing materials and roofing accessories. These include, but are not limited to:

1. Slate roof shingles – intent is to match historical samples in color, size, distribution, etc.
2. Standing seam metal roof – generally not an acceptable roofing material, especially for the campus core
3. Roof accessories and trim – copper or dark bronze coloration preferred (but subject to review).
4. Roof accessories and trim – if required; avoid residential looking gutters and downspouts

5.5.2.1 Preroofing Conference

A pre-roofing conference is required and shall be included in the Specifications as part of DGS-30-326, "Special Requirements for Low Slope Roofing Membranes." The conference shall be held before ordering roofing materials.

Representatives of the University (including the roofing inspector), A/E, General Contractor, roofing contractor, deck contractor, mechanical contractor, and roofing manufacturer shall attend.

Review of plans, specifications, flashing details, work scheduling, and workmanship standards is required. Problems and discrepancies shall be resolved.

A written record of proceedings shall be prepared and made part of the job record.

5.5.2.2 Guarantees

Guarantees and warranties for new construction or reroofing are included in the Specifications as part of DGS-30-326, "Special Requirements for Low Slope Roofing Membranes." Additional requirements, warranty period length, or University-approved waivers/exceptions may be specified by the

A/E in the roofing specifications. Identify the DGS form section being modified in the roofing specification.

5.5.2.2.1 Roofing Contractor's Guarantee

Provide the following roofing contractor's guarantee on the General Contractor Guarantee form:

"The roofing contractor shall guarantee materials and workmanship associated with the roofing, flashings, and sheet metal work incidental to the work required under the roofing subcontract, against defect due to faulty materials or workmanship for a period of two years from the Final Completion Date of the entire project. It is understood and agreed by all parties hereto that the responsibility of the roofing contractor under this guarantee form or any contract document, shall be in accordance with the roofing contractor's limited guarantee."

5.5.2.2.2 Owner's Agreement

Provide the following Owners Agreement on the Contractor Guarantee form:

"The University agrees, from the Final Completion Date of the entire project, to maintain the roof in accordance with the manufacturer's written requirements and also agrees to avoid damage to the roof surface by any parties under its control working or walking on the roof. The University recognizes its responsibility to inspect the roof semiannually."

5.5.2.2.3 Contractor's Guarantee for New Construction

The Contractor shall furnish, as a minimum, a manufacturer's 20-year total system material and labor warranty/guarantee with no monetary limitations (NDL, no dollar limit) from the Final Completion Date of the entire project. The contractor shall provide a workmanship warranty agreeing to maintain the entire roof system(s) in a completely watertight condition at no cost to the University for two years from the Final Completion Date of the entire project. Sheet metal flashing incidental to the roofing shall be covered under the manufacturer's warranty.

Exception: Roofs less than 5,000 sq. ft. in area and roofs on utility or unoccupied structures shall have a minimum 10-year total system warranty.

5.5.2.2.4 Contractor's Guarantee for Reroofing

The Contractor shall furnish, as a minimum, a manufacturer's 20-year total system material and labor warranty/guarantee with no monetary limitations (NDL, no dollar limit). The contractor shall provide a workmanship warranty agreeing to maintain the entire roof system(s) in a completely watertight condition at no cost to the University for two years from date of final acceptance. Sheet metal flashing incidental to the roofing shall be covered under the manufacturer's warranty.

Exception: Roofs less than 5,000 sq. ft. in area and roofs on utility or unoccupied structures shall have a minimum 10-year total system warranty.

5.5.2.3 NRCA Roofing Manual

Use the latest edition of the NRCA Manual as a guide in preparing plans and specifications for all new roofing projects and for reroofing projects to the extent practicable unless:

1. The NCRA Manual conflicts with provisions of this document, or
2. The A/E obtains approval from the University to use different details and provisions.

5.5.2.4 Bidding Roofing Systems

Specifications shall include bids for only one type of roofing system. For the purpose of bidding, KEE, NPB, PVC and TPO shall be considered one roofing system. Single-ply and multi-ply roofing systems shall not be bid as alternates.

5.5.2.5 Materials Certification

1. Materials Certifications shall be included in the Specifications as part of DGS-30-326, "Special Requirements for Low Slope Roofing Membranes," that the materials shall be labeled with ASTM certification numbers or other specified product certifications or the Contractor shall give to the A/E the roofing manufacturers certification that the roofing materials being furnished comply with specified ASTM and approved standards.
2. The owner's full-time roof inspector shall verify the materials received are as specified and in accordance with A/E approved shop drawings before roofing materials may be installed.

5.5.2.6 System Evaluation

The A/E responsible for roofing design shall evaluate and specify the roofing system(s) for:

1. Fire resistance rating
2. Wind uplift resistance (including roof system and sheet metal flashing components)
3. Warranty
4. Tear resistance
5. Attachment
6. Resistance to harmful local chemicals
7. Membrane compatibility with insulation
8. Type of membrane seams and joints

5.5.2.7 Single-Ply Membrane (SPM) Specifications

1. Specify SPM completely with latest listed ASTM and performance criteria.
2. SPM, if specified with either manufacturer or brand-name products, shall be specified with three manufacturers and three equivalent products.
3. The single-ply membrane manufacturer's representative shall check installation procedures at start-up and inspect the completed membrane installation.

5.5.3 Non-Destructive Evaluation Roofing Surveys

A non-destructive evaluation (NDE) survey uses infrared, nuclear, impedance moisture, electronic field vector mapping or electronic leak detection to locate unacceptable moisture within a roofing system.

An NDE survey is mandatory before a newly constructed roof may be accepted. Depending on the size and condition of an existing roof, a survey may or may not be required before the repair or replacement of a roof. The following outlines requirements for NDE surveys:

1. Equipment, subject to the University's approval, shall be equal to the following:
 - a. Infrared: A camera designed for the intended application and capable of taking thermograms. Instrument sensitivity shall permit recognition of areas of wet insulation as small as 6 inches on a side.
 - b. Nuclear: A nuclear hydrogen detection (NHD) meter used for the measurements of reflected neutrons that can be linked to the presence of water in the roofing system

- c. Impedance Moisture Survey: Scanner designed to detect and evaluate non-destructively comparative moisture conditions within roofing and waterproofing.
 - d. Electronic Field Vector Mapping (EFVM) or Electronic Leak Detection: Generator and receiver designed for the intended membrane leak detection used for roofing and waterproofing.
2. Operators of equipment shall be certified in the equipment used and licensed as required for by the survey protocol.
3. Surveys
- a. Infrared: Provide a complete survey of the roof or roofs. Outline all anomalies on the roof. Provide a thermogram showing the outlines and daylight photographs of all anomalies. Survey inspection procedures, reports, etc., shall be conducted in accordance with the requirements and procedures in ASTM C1153, “Standard Practice for Location of Wet Insulation in Roofing Systems Using Infrared Imaging,” except as otherwise noted in this section.
 - b. Nuclear: Provide a grid, comprising 5' × 5' grid unit, to completely cover the roof or roofs. Mark each grid intersection with spray paint. Take readings at the inter-sections and record them on a roof plan. Provide daylight photographs of area of anomalies. Survey inspection procedure, reports, etc., shall be conducted in accordance with the requirements and procedures of ANSI/SPRI/RCI NT-1, “Detection and Location of Latent Moisture in Building Systems by Nuclear Radioisotopic Thermalization,” except as otherwise noted in this section.
 - c. Impedance Moisture Survey: Provide a complete survey of all roof or waterproofing areas. Mark, number, and photograph all anomalies on the membrane surface. After field testing is complete submit a report with all anomalies located on a roof plan. Photographs of each anomaly shall be included in the report. Mapping shall be done in accordance with standard practices over the entire roof surface. Survey inspection procedures, reports, etc., shall be conducted in accordance with the requirements and procedures of ASTM D7954, “Practice for Moisture Surveying of Roofing and Waterproofing Systems using Non-destructive, Electrical Impedance Scan,” except as otherwise noted in this section.
 - d. Special Surveys using electrical conductance measurement methods to locate leaks in roofing systems – Electronic Leak Detection or Electronic Field Vector Mapping (EFVM): This system may be used on roof areas where full time roof inspector has noted that there is no detrimental moisture observed in the roof system during the daily observations.

Provide a complete survey of roof or waterproofing areas as directed. Mark, number, and photograph all anomalies on the membrane surface. After field testing is complete submit a report with all anomalies located on a roof plan. Photographs of each anomaly shall be included in the report. Survey inspection procedures, reports, etc., shall be conducted in accordance with the requirements and procedures of ASTM D7877, "Standard Guide for Electronic Leak Detection methods for Detecting and Locating Leaks in Waterproof Membranes," except as otherwise noted in DCSM section 5.5. Roof cores shall be taken at all leaks to determine the extent of damage by the leak if roof insulation is below the roof membrane and above the deck. Roof cores may be omitted if the roof inspector is to be present to observe the roof contractor's repair of the roof leak by opening roof and removing wet insulation. Wet insulation is determined in the field by the roof inspector. Fees for the roof inspector and retesting shall be paid by the contractor by change order to the contract. For Electronic Leak Detection, test the roof area on an area by area basis not to exceed 5,000 sq. ft. Readings taken with the receiver shall be done on a 24" × 24" grid pattern.

4. Core Samples

Because NDE surveys are not able to measure moisture in roofs directly (nuclear equipment responds to hydrogen emissions, infrared to heat changes), core samples to measure actual moisture content must be taken from surveyed roofs and correlated with NDE readings (see the exception below for roofs with no anomalies). The samples shall be taken as follows:

- a. One is required on roofs showing no anomalies.
- b. On all other roofs a minimum of one dry and one wet core shall be taken from each roof surveyed where anomalies are present. Additional cores are not required if the Consultant can show that moisture is not causing detected anomalies. The Consultant shall identify such anomalies and explain their cause in a written report to the University.
- c. As many cores as needed should be taken to verify non-destructive testing data results, but no more than five cores shall be taken from any roof area except as noted in the test protocol.
- d. Exception: If no anomalies are shown by the survey equipment and the University's full time roof inspector was present on the site during all roofing applications and had not noted any roofing applications where moisture was present in the form of rain, dew, mist or entrapped moisture the requirement for a minimum of one roof core into a newly installed assembly may be waived by the University.

5. Gravimetric Analysis
 - a. As soon as possible after samples are taken, core should be sealed in air tight containers and taken to a laboratory for analysis.
 - b. Analyze samples gravimetrically per ASTM D1864 to determine percent of moisture in any required core sample taken from new roofs and, unless waived for justifiable reasons, from existing roofs.
 - c. Identify all materials in the cores – surfacing, membrane (and number of plies), insulation, vapor barriers, adhesives, etc.
6. Moisture Conditions
 - a. The Surveyor shall correlate survey reading results with actual moisture conditions determined by core samples gravimetrically analyzed. The correlation shall be shown or tabulated on the drawings.
7. Report
 - a. The Consultant shall submit a written report explaining the problems.
 - b. Reports for existing roofs shall:
 - i. Identify and describe all anomalies.
 - ii. Identify and describe any visual survey defects that may be harmful to the roof.
 - iii. Give the causes for each anomaly and defect.
 - iv. Recommend alternate courses of corrective action for defects and anomalies harmful to the roof.
 - v. Provide the cost estimate for correcting the defects and anomalies.
 - c. Reports for new roofs where a design professional is providing construction administration services shall:
 - i. Identify and describe all anomalies.
 - ii. Identify and describe any visual survey defects that may be harmful to the roof.
 - iii. Give the causes for each anomaly and defect.
8. Drawings

The Consultant shall prepare drawings that include the following as a minimum:

 - a. Plans shall show all roofs surveyed.
 - b. State identification, title, date, and use of the building.
 - c. Name, address and phone number of VT PM.
 - d. Make, model and serial number of equipment used.
 - e. Name of operator and data analyst.
 - f. The survey technique used.
 - g. Condition of the roof surface at the time of the survey.

- h. Date, time and weather conditions at the time of the survey.
- i. Description of the roofing and waterproofing assembly.
- j. Provide an orientation north arrow and drawing scale
- k. Indicate the area of each roof and approximate overall dimensions
- l. All existing features, equipment, and roof penetrations of whatever nature (such as vents, stacks, drains, hatches, skylights, screens, railings, mechanical equipment, etc.) shall be accurately indicated and identified.
- m. Show and explain all roofing defects and anomalies.
- n. Delineate, for an infrared survey, moisture anomalies with contour lines; for a nuclear survey, show all grid point readings and define areas having unacceptable moisture by contour lines. Indicate where core samples were taken. Correlate nuclear grid point readings and infrared contour changes to percent of moisture. Dimension areas recommended for removal and locate them with respect to fixed identify-able features (such as parapets).
- o. Provide at least one detail section showing roof construction where core samples were taken; more if there are differences in construction from core to core. Identify surfacing material, membrane product, insulation type and thickness, vapor barrier if used, and deck construction.
- p. A statement shall be made of the basis for the unacceptable moisture content levels established for each material present. See survey protocols.
- q. Other information as required or listed in the survey protocol.

5.5.4 Reroofing

5.5.4.1 Roof Survey for Reroofing

Before reroofing a facility or making major repairs, the University shall procure a roof survey performed by an experienced and qualified inspection service. See qualifications for a roof consultant/inspection services provider in DCSM section 8.3.5 The roof survey shall use NDE moisture detection methods indicated in DCSM section 5.5.3. For roof repairs or replacement where asbestos materials may be present, an asbestos survey shall be performed and the findings reported in writing.

5.5.4.1.1 Exception

For roofs that are very small or that have reached an advanced stage of deterioration and where a roof survey does not appear cost effective, the University may request a waiver of the roof condition survey after determining the conditions by visual inspection. The request must be

accompanied by a roof plan sketch with features noted, a written description of the problems cross referenced to the plan, an approximate area of the roof, and photographs showing the conditions which support the request. An asbestos assessment is required.

5.5.4.2 Reroofing Requirements

If complete reroofing is required for over 25% of the roof area in a calendar year:

1. Provide secondary (emergency) roof drains in accord with the requirements for new construction.
2. Provide guarantees for new construction
3. Provide insulation in the roof covering assembly in accord with the requirements for new construction.

5.5.4.3 Reroofing – Secondary (Emergency) Roof Drains in Reroofing Projects

If secondary (emergency) roof drains are not a part of the existing construction, then secondary roof drains shall be provided as part of reroofing work. Structural calculations shall be submitted that demonstrate that the structure is adequate to sustain the accumulated water up to the elevation of the secondary roof drains in accord with ASCE 7, section 8.5. Scuppers are permitted.

5.5.5 Roof Load

The minimum design superimposed load for flat roofs and roofs with a slope of less than 4 inches per foot shall be as indicated on the follows. Generally, roofs in areas in and west of the Blue Ridge Mountains and the indicated areas of Northern Virginia shall be designed for a minimum design superimposed load of 30 pounds per square foot. Indicated areas east of the Blue Ridge Mountains shall have a minimum design roof superimposed load of 20 pounds per square foot for roof design. Greater live, snow, and/or combination loads shall be used where local experience, calculations, drifting or other conditions dictate.

5.5.5.1 Addition of Loads to Existing Structures

Prior to mounting any antennae, microwave dishes, HVAC equipment or other items on the roof of an existing building, the adequacy of the structural framing to support the additional live, dead, wind, and lateral loads shall be verified by a licensed structural engineer. Consideration must be given to deflection from the added load(s), to potential for vibration, to

potential for ponding water and to the consequences of overturning moments on stressed attachments and construction.

5.5.6 Low-Slope Membrane Roofing

The following requirements are generally applicable to all low-slope roofs. Contractor specific requirements for the items listed below are included in the Specifications as part of DGS-30-326, "Special Requirements for Low Slope Roofing Membranes."

5.5.6.1 Roof Slope

1. All new roofs shall slope $\frac{1}{4}$ " per foot, minimum, to drains.
2. Dead level valleys are unacceptable. Roof cricket valleys shall slope a minimum of $\frac{1}{8}$ " per foot unless impractical.
3. No ponding for any amount of time on new roofs is permitted.

5.5.6.2 Wind Uplift

Roof assemblies shall be designed to resist the uplift loads as calculated using the current VCC edition of ASCE 7 for field, perimeter, and corner conditions. Low slope membrane edge systems, except gutters, shall be designed and installed for wind resistance in accordance with ANSI/SPRI ES-1.

For additional information on wind design see the following:

1. Factory Mutual (FM) P7825
2. Factory Mutual (FM) Property Loss Prevention Data Sheet 1-29
3. Factory Mutual (FM) Property Loss Prevention Data Sheet 1-28
4. Single-Ply Roofing Institute (SPRI) SPRI RP-4 Wind Design Standard for Ballasted Single-ply Roofing Systems

5.5.6.3 Insulation

Unless otherwise required to comply with a Manufacturers roofing system or by University-approved waiver, insulation shall be as follows, except as noted:

1. C or R (per inch) factor
2. Two layers, if thickness permits
3. Staggered joints
4. Roof insulation securement shall be specified in the roofing specifications. Mechanically fasten the first layer to metal deck. Cold applied adhesives and/or low rise foam products are acceptable for the attachment of the first layer to concrete decks, and for attachment of

the individual insulation layers to each other contingent upon meeting FM I-90 wind uplift rating and the specified roofing material manufacturer's warranty.

5. Compatible Insulation: The A/E shall assure the University that the specified type of insulation has been investigated and is entirely compatible with contiguous, specified roofing materials.

5.5.6.4 Rooftop Equipment

1. See DCSM section 3.1 for safety requirements if rooftop equipment is required.
2. Comply with NRCA Roofing Manual recommendations including minimum height of equipment above the roof membrane when equipment is supported above the roof surface.
3. Design clearances and details for easy re-roofing.
4. Provide prefabricated walks to and around equipment that requires servicing; walks must not block roof drainage.

5.5.6.5 Approved Applicator

The roofing and base flashing applicator shall be approved by the materials manufacturer.

5.5.6.6 Roof Protection

1. Before moving equipment or materials over a roof, the University, General Contractor, roofing contractor, and any of their agents must inspect and document the roof conditions and protect the roof from damage during and following roofing work.
2. Movement of equipment and materials without roof protection shall be cause for the University, General Contractor, roofing contractor or A/E to stop work until protection is provided and any damage is corrected.
3. The University's roofing inspector shall record all such violations.

5.5.6.7 Acceptable Low-Slope Roofing Membranes

1. Roofs with slopes less than 4-in-12 pitch shall be black EPDM membrane with a minimum thickness of 60 mm.
2. Ballasted systems are not acceptable for new construction.
3. Existing Ballast systems shall be replaced with black EPDM with a minimum thickness of 60 mm.
4. All membrane roofs shall have a minimum of 20-year NDL warranty.
5. Mechanically fastened systems are not acceptable.

6. Service walkways shall be a minimum of 24-inches wide and appropriately located to service all rooftop equipment from the roof access point.
7. EPDM membrane shall be obtained from an approved manufacturer. Approved manufacturers include:
 - a. Carlisle
 - b. Firestone
 - c. Versico

5.5.6.8 Plaza Decks

Plaza decks, when constructed over occupied spaces, are considered to be roofs and shall use roofing membranes as indicated in DCSM section 5.5.6.7. Where plaza decks are accessible to personnel, implement the fall protection safety requirements in DCSM section 3.1.

5.5.7 Shingles

1. Natural Slate Shingles
 - a. Shall have a minimum thickness of ¼ inch.
 - b. Have a unit weight of not more than 900 pounds per square.
 - c. The basis of design for the color shall be Buckingham Black Slate or similar, as approved by OUP.
 - d. The length shall be 18 inches.
 - e. The width shall be 12 inches.
 - f. Shall match existing shingles if a renovation project where the entire roof is not replaced.
2. Simulated Slate Shingles
 - a. Shall have a minimum thickness of ¼-inch tapered.
 - b. The basis of design for the color shall be Ecostar™ Majestic Slate™ or similar, as approved by OUP.
 - c. The butt shape shall be a Standard Square Cut.
 - d. The length shall be 18 inches.
 - e. The width shall be 12 inches.
3. Synthetic Slate shall be considered as an alternative to Natural Slate, with materials to be reviewed and approved by the University. Synthetic Slate installation shall require a random mixture of similar dark colors to eliminate a homogeneous appearance.

5.5.8 Standing Seam Metal Roofing Panels

1. Size: nominal 16 inch coverage
2. Seam height shall be a minimum of 1½ inches with a maximum of 2 inches.

3. The panels shall be mechanically seamed for double locked side lap.
4. The use of stiffening ribs is acceptable.
5. All standing seam metal roofing shall be manufactured domestically.

5.6 ROOF DRAINAGE, EQUIPMENT, AND ACCESSORIES

5.6.1 Gutters and Downspouts

1. For copper gutters and downspouts there shall be a minimum of 16 oz./sq. ft. of copper.
2. All gutters shall have positive drainage to downspouts. Additional downspouts shall be added to maintain positive drainage in all gutters.
3. Downspouts shall tie directly to the underground storm drainage system.
4. Round profile downspouts are preferred.

5.6.2 Snow Guards

1. Snow guards are to be provided over all entrances with roofs that have a slope of 6-in-12 or greater.
2. Snow guards shall be mechanically fastened. The use of adhesively fastened snow guards is prohibited.
3. For renovations, consider structure strength before adding snow guards.

5.6.3 Rooftop Safety

Fall protection systems shall be permanently installed in new construction. Retrofit fall protection systems shall be installed in all roof replacement projects. See DCSM section 3.1 for more information.

5.6.4 Roof Hatches

1. Roof hatches are to be insulated to the same standard as the subject roof and provided with a hasp for a padlock.
2. Provide roof hatches with a hold-open mechanism.
3. Spring-loaded roof hatches are not acceptable.
4. Alternating tread devices to access hatches are not acceptable.

5.7 DOORS AND WINDOWS

5.7.1 Interior Doors

1. When interior doors are wood they shall be stain grade and solid core. Standard size shall be 3'-0" × 7'-0" × 1¾". All doors shall comply with ADA and ANSI 117 requirements.

2. Residence hall interior doors shall be solid wood style and rail construction with laminate veneer. Color shall be application specific and approved by the University.
3. Power operators shall be electro-mechanical. The basis of design manufacturer is Stanley.

5.7.2 Door Hardware

1. The basis of design for all locks and latches shall be Best 9 K3 series X15D lever design to accept Cormax 7 pin core.
2. University Key Shop shall provide all cores and keys that are to be paid for through the project and not the Contractor. A/E and/or Contractor shall provide an approved door and hardware schedule to the University Key Shop.
3. The basis of design for deadbolts shall be Best 82T series to accept Cormax 7 pin core.
4. The basis of design for all interior locks in residence halls shall be networked electronic locks Schlage AD400 series. Networked locks to be installed using wireless infrastructure.
5. The basis of design for networked locks shall be Schlage AD400CY70MTK x RHO x BD x 626 with Virginia Tech Custom Key with University Standard Cbord CS Gold Access Control System.
6. The basis of design for all removable mullions shall be lockable/key removable Von Duprin #KR4954/KR9954.
7. The basis of design for all door closers shall be cast iron cylinder with forged forearms and parallel arms with non-ferrous full covers, LCN 4040XP series.
8. The use of floor closers and concealed closers is prohibited.
9. The basis of design for low energy operators shall be LCN 9500 Senior Swing equipped with an electric strike or electric latch retraction.
10. The basis of design for all electric power transfers shall be Von Duprin EPT10.
11. The basis of design for all electric strikes shall be Von Duprin 6000/6300/6400 series.

5.7.3 Electronic Door Access Control

This section provides guidelines for the A/E's specification on Electronic Safety. These items are to be coordinated to meet the other requirements in the DCSM. The A/E shall schedule a meeting through the VT PM with the Hokie Passport Office, VTPD, and building occupants.

5.7.3.1 Selection of Electronic Door Hardware

Selection of electronic door hardware will vary depending on many factors, including building code, facility design and construction, architectural style, and safety.

While situations vary, the following general guidelines shall be followed when specifying electronic hardware:

1. Function shall be fail secure
 - a. Hardware provides free mechanical egress
 - b. No connection is required to building fire alarm system
 - c. Note that certain safety or fire code provisions may dictate the use of failsafe hardware and interconnection with the building fire alarm system for specific doors. These exceptions must be approved by the UBO.
2. Electrified locks, electric strikes, and electric trim shall be either 12 VDC or 24 VDC.
 - a. The University will provide filtered and regulated 12 VDC or 24 VDC to power electric strikes, locks, and trims.
 - b. Separate power supplies shall not be provided with the hardware.
 - c. Up to 16 low current strikes or trim devices can be operated from a single filtered power supply.
3. Electric latch retraction devices
 - a. These typically require a manufacturer-specific power supply. The high in-rush current dictates conductor size and maximum cable length to power supply.
 - i. Maximum cable length may dictate installation of the power supply near the door.
 - ii. The power supply must be accessible.
 - iii. Where possible, mount the power supply in the access control closet.
 - b. Power supplies require 120-volt AC cord and plug connection
 - c. Specify hardware which includes battery backup integral to power supply
4. ADA doors with automatic operators shall be equipped with electric strike or electric latch retraction device.
 - a. If pulls are desired on both leaves of double doors, both leaves shall receive electronic hardware (i.e., both doors unlock/unlatch on card swipe).

- b. If electric hardware is not desired on both leaves, the inactive leaf shall not be equipped with an exterior pull.
- c. Double doors with a single active leaf and one inactive leaf must be configured to ensure positive latching of the inactive leaf whenever the active leaf is closed and latched. The preferred solution is to equip the inactive leaf with automatic flush bolt(s) and door coordinator.
- d. Magnetic locks are discouraged due to increased safety concerns (connection to fire system, local physical bypass switch, etc.) and must be approved by the UBO.

In addition to standard electronic hardware which can be activated/controlled via relay contact closure or application of power, the basis of design shall be the following specialty products that are integrated with and fully configurable through CS Gold:

- 1. Schlage AD-300 networked wired locks
- 2. Schlage AD-400 networked wireless locks
 - a. Note: The Schlage AD-400 is currently the only wireless lock approved for use with CSGold.
 - b. PIMs should be programmed for Dynamic Control Switching (DCS) to reduce PIM to lock communications failure.

These specialty hardware options require far less door and frame preparation than standard hardwired installations, and can in some instances significantly reduce installation costs.

We recommend the Schlage AD series locks not be used on exterior doors because they are not as resistant to weather as the wired options.

5.7.3.2 Infrastructure

Infrastructure for electronic access control projects shall be provided by the A/E and shall include:

- 1. A dedicated location for installation of access controls
 - a. Preference is for a dedicated room/closet with:
 - i. Locking door with electronic hardware and card reader
 - ii. A minimum of 16 square feet available wall surface area shall be provide for buildings with 1 to 30 doors; buildings with 31 or more doors will require a minimum of 32 square feet. Any doors that are near this area will swing outward and away from this area.
 - iii. Controlled temperature and humidity

- iv. Minimum two each dedicated 120-volt 20-amp quad receptacle on emergency circuit with generator backup (if available). Facilities with large numbers of controlled doors or extensive use of latch retraction devices may require additional circuits or outlets.
 - v. Network (data) drop
 - vi. Open paths/sleeves to pull cable from controls to door locations
- b. Accommodation can be made for a less secure space, as long as access to the space is restricted (i.e., no general public) and meets the other requirements noted above.
2. Cable Path
- a. A closed and secure cable path (conduit, flex) from accessible ceiling to points of termination within the door and door frame. Sample sketches are located in the door access details located in the VT Design Standard Detail Library. These are representative sketches intended to convey preferred routes for cable and typical installation details for various components and local conditions. In addition to these line drawings, the points below shall be verified during design and construction.
 - b. In many instances access control cables use the same cable paths as NI&S network cables. Conduits, risers, and cable trays must be sized or added to accommodate the access control cables and not interfere with the NI&S network.
 - i. AC power shall not be run in the same conduit or junction box as low voltage access control cable.
 - ii. Proximity Infrared (PIR) sensors are no longer installed unless specifically required.
 - iii. Junction boxes shown in the sample sketches may be omitted if the following conditions are met:
 - 1. obtain prior written approval by the VT PM
 - 2. individual conduits can be stubbed above doors in a concealed but accessible ceiling.
 - 3. conduits are grouped in one location (no more than 12 inches between outermost conduits) to allow for splitting of the composite access control cable bundle and routing of the individual component cables to their points of termination within door and frame.

- iv. Conduit routed to door frame shall have the minimum number of wide radius bends required to reach the desired location. In no instance shall bends exceed 180 degrees without an intermediate (and accessible) junction box or pull “L”. Minimum conduit size to accommodate composite cable is 1 inch.
- v. Pull strings shall be installed from junction box (or stub-out above ceiling) to point of termination in all conduits.
- vi. Grouted frames shall be equipped with mortar boxes around electric hinges, electric power transfers, electric strikes, door contacts, etc.
- vii. Use of factory installed raceway within hollow metal frames is encouraged.
- viii. Where ADA operators are installed:
 - 1. A minimum of one ADA push button must be hardwired to the ADA operator.
 - 2. Card reader shall be installed adjacent to ADA pushbutton, and may share a common conduit run.
 - 3. ADA operators must be integrated with the access control system to allow access with valid credentials.
 - 4. Four more 18 AWG conductors are needed to be run to each ADA door to integrate the actuator with the access control system.
 - 5. Egress will always be allowed.

5.7.3.3 Installation Responsibilities

Power supplies for latch retraction hardware shall be provided by hardware supplier. The University provides the following components and services with respect to access control projects:

- 1. Squadron access control modules
- 2. Enclosure for Squadron controls (where required)
- 3. Card readers – with weather shields and reader splice boxes if applicable
- 4. Installation services through separate contract shall include mounting and connecting:
 - a. Squadron panels
 - b. University provided power supplies
 - c. Card readers
 - d. Request-to-exit devices

- e. Termination of cabling to electrified hardware provided by the General Contractor

Note that, if desired, door contacts may be prepped and provided by door supplier.

5.7.4 Windows

For windows for punched openings (especially in historic, legacy, or contributing-legacy buildings as identified in the campus master plan) use one of the thermally-broken windows selected by OUP as a basis of design.

5.7.5 Safety

For more information about safety with doors and windows, refer to DCSM section 3.5.

5.7.6 Locksets and Access Control

1. Locksets shall be cylindrical locksets, Series 4000, Grade 1 (ANSI A156.2), 93K lever handle with through bolted trim, round rose – varying in size between 2-9/16" to 3³/₈" or largest available size.
2. The basis of design for locksets shall be locksets complete with a combined core and must accept a Best 7-pin interchangeable core, no substitutes. Contractor to work through the VT PM with the University Key Shop to determine how to combine cores and cut keys.
3. The University Key Shop personnel shall accomplish the final keying and installation of cores. Construction cores may be installed by the contractor during construction, but must be removed prior to beneficial occupancy. The University Key Shop shall have a copy of all construction keys.

5.7.7 Exterior Doors

1. OUP shall be consulted on all openings. These include, but are not limited to:
 - a. Wood doors – Units selected should match color and grain of historic wood doors
 - b. Door hardware – Certain spaces (e.g., lactation rooms) have specific door hardware needs. Include discussion of specialty spaces in keying conference and note special access control needs in door schedule.
2. At least one door for each set of entry doors shall be power operated. The left hand leaf, as viewed from the exterior, shall be the power operated door. Prevailing wind must be considered in the selection of which door shall be power operated; exception to the above left hand preference shall be taken if the prevailing wind will interfere with proper operation.

- a. Operators shall be electro-mechanical. The basis of design manufacturer is Stanley.
 - b. Power operated egress doors shall have an electronic strike or latch to allow power operation during times the building is locked. Power actuated exit devices shall not be used.
 - c. Radio controlled remote actuators shall be wall or post mounted. Post mounting shall be the manufacturer's unit unless otherwise directed by the University. Placement of the actuator must be in a fully accessible and visible location.
3. Exterior door electronic power operators shall have auxiliary contacts to allow for card reader and proximity reader activation of the openers.
 4. Every exterior door opening shall be prewired for an electronic access control reader that is coordinated with the access control plan.
 5. Every exterior door opening shall be provided with a door position switch which will allow remote monitoring and alarming capabilities.
 6. All door hardware shall be provided with hex nuts and through bolts.
 7. The basis of design for all exit devices shall be Von Duprin 33A/99 series.
 8. Provide all exit device trims with forged brass, full escutcheon. Lever trims shall be "breakaway type" with substantial resistance to rotation when locked but allowing the vandalized lever to drop to a vertical, 90 degrees, position when more than 35 pounds of torque is applied.
 9. Provide concealed vertical cable exit devices when necessary.
 10. All exits not managed by Hokie Passport shall be provided with a deadlatching (deadlocking) latchbolt feature for security and/or for future addition of alarm kits and/or other electrical requirements.
 11. The basis of design for all exterior door hinges shall be Select continuous geared hinges #SL14 HD.

5.7.7.1 Double/Pairs of Doors

Pairs of doors, whether dissimilar or similar in size, shall adhere to the following standards:

1. Door opening viewed from the exterior/secure side, the right door shall be defined as the "Primary" door and the left side door shall be defined as the "Secondary" door.
2. No hardware trim is permitted on the exterior/outside of "Secondary" doors.
3. Door hardware shall not be provided and installed in a manner that would allow two doors to be zip-tied, chained, cabled, or any other method of being secured together.

4. Any door designed with a glass lite that creates a gap between the back of an exit device's mechanism case (tube/channel) shall be filled-in.

5.7.8 Horizontal Louver Blinds

For Residence Halls: Student rooms – 1" mini blinds in a white color.

5.7.9 Window Shades

For Residence Halls:

1. Common Areas – Roller shades - 3% openness in a neutral color, control placed on the right side.
2. Apartments – Black out shades in a neutral color.

5.8 STRUCTURE

5.8.1 Grouting

The selection of zero or low VOC mortars, grout, and sealants will help to eliminate indoor air quality problems. All floors and wet walls shall receive an epoxy grout. Avoid the use of white and light-colored grouts.

5.8.2 Gypsum Board Assemblies

For Residence Halls: Gypsum wall board shall be impact resistant sheetrock. Light orange peel spray finish shall be applied. Contractor to provide mock-ups (see DCSM section 1.7.1).

5.9 DESIGN AND FINISH CRITERIA

5.9.1 Finish Carpentry

1. Avoid depletion of natural resources by specifying wood species from sustainable sources, such as Forest Stewardship Council (FSC) Certified Wood or regionally harvested wood from abundant species. Avoid use of exported or exotic species such as mahogany that are limited in supply or not sustainably harvested. Products shall be free of urea-formaldehyde binders, copper, and arsenic.
2. Casework may be wood or clad with a plastic laminate.
3. Wood trim is acceptable in certain areas and may be requested if trying to match existing conditions.

5.9.2 Acoustics

1. Acoustics must be a consideration in all University projects. Acceptable forms of acoustic treatment include but are not limited to:

- a. Flooring
 - b. Vertical Panels
 - c. Ceiling Treatment
 - d. Lighting
2. Classroom A/V, a team within the Office of the University Registrar, shall be consulted on acoustical considerations for future learning space projects.
 3. Classrooms should receive acoustical considerations in order to provide an unimpeded learning environment. Consider acoustic standards and reasonably adhere to guidelines set in ANSI/ASA S12.60 Part 1: Acoustical Performance Criteria, Design Requirements, and Guidelines for Schools. Examples include, but are not limited to, the following items (ANSI/ASA S12.60 Standard citations in parentheses below):
 - a. (5.2.1.1) Unoccupied, furnished learning spaces must not:
 - i. Exceed 35 dB (A weighted)/ 55 dB (C weighted).
 - ii. Surpass the maximum permitted reverberation times for SPL's in octave bands with mid band frequencies of 500, 1000, 2000 Hz:
 1. 0.6 seconds in smaller classrooms.
 2. 0.7 seconds in larger rooms.
 - b. (5.2.2.1) Must comply with HVAC SPL regulations based on type and class.
 - c. (5.5.1) Classroom audio distribution systems, if installed, shall not be used as a substitute for achieving the acoustical design requirements of this standard.
 - d. (Annex A) Proper testing should be conducted post construction to confirm compliance.

5.10 PARTITIONS

5.10.1 General

1. Metal stud wall framing shall be designed using the Steel Stud Manufacturers Association (SSMA) Product Technical Guide.
2. The structural design of framing members shall be designed for the appropriate loads. The minimum size necessary for the strength and serviceability shall be indicated on the construction documents. Upsizing of members for economy of scale shall be indicated by the fabricator, not the designer. Member utilizing less than 75% of the proposed member's available strength shall be justified by calculations.

5.10.2 Fire Rated Assemblies and Fire Stopping

Specify fire rated plywood for NI&S rooms as blocking. Coordinate with NI&S for locations.

5.10.3 Blocking and Miscellaneous Carpentry

1. Fire rated wood blocking shall be provided where required.
2. Residential bathroom cabinetry shall be plywood with finish approved by Student Affairs.

5.11 INTERIOR SIGNAGE

See Appendix E: Interior Signage Standards Manual.

5.12 LIGHTING

5.12.1 Specifications

1. OUP shall be consulted on the color temperature of interior lighting.
2. LED lighting is required for all new and renovation projects.
3. No lighting fixtures shall be specified for which the manufacturer will require a minimum order for the purchase of replacements. Non-catalog and custom lighting fixtures are to be economically justified and avoided whenever possible.
4. Locate light fixture schedule on drawings. Schedule shall contain a description of the fixture, not simply a model number.
5. Use of dimming systems is restricted except for conference rooms, auditoriums and very large classrooms. When approved, the dimming range shall be 100% to 1%.
6. All components shall be standard products in production in the USA a minimum of 5 years. Daylight harvesting systems specification shall also require job specific installation instructions and wiring diagrams for use during installation. Record as-built drawings indicating any changes for these systems shall also be provided upon project completion.
7. Lighting systems installed shall not exceed allowable Watts per square foot based on the latest IECC adopted by the Commonwealth of Virginia.
8. Lighting average illumination in foot-candle (or lux) shall be as recommended by the latest Illuminating Engineering Society of North America (IESNA) Publication.
9. The halogen MR16 lamp is not allowed; however, the LED MR16 is acceptable.

10. A minimum of 2 support wires shall be provided per lay-in fixture on the diagonal unless additional support is necessary due to seismic consideration.
11. Light fixtures shall be supported per manufacturers' recommendations.
12. Stairwell light fixtures shall be wall mounted above landing floors at a maximum of 8' above finished floor.
13. LED downlights provided shall have replaceable drivers that are easily accessible.
14. LED lighting: Use UL listed 120 or 277 V luminaires with the following performance characteristics:
 - a. Minimum lumen efficacy:
 - i. 100 lumens/Watt for general lighting
 - ii. 75 lumens/Watt for accent and display lighting, down lighting, and special purpose lighting.
 - b. Correlated color temperature:
 - i. 4000 K for classrooms and labs
 - ii. 3500 K for general lighting and down lighting
 - iii. 2700 K for accent and display lighting.
 - c. Color rendering index: 90 or better.
 - d. LED design life: not less than 50,000 hours.
 - e. Driver System Design Life: Not less than the LED design life.
 - f. Power factor: 0.9 or better.
 - g. Design ambient temperatures: 95 °F
 - h. Fixture efficacies shall improve above listed requirements.

5.12.2 Emergency and Exit Lighting

1. Emergency lighting and exit signs shall be provided through the use of fixtures on emergency generator or dedicated battery backups.
2. Connect emergency lights to generator if available. Do not provide battery backup emergency lights if a generator is available.
3. Virginia Tech requires the use of LED lighted exit signs with a typical lamp life of 10 years minimum. Utilize chevron directional indicators when required. Only red lettered exit signs will be used.
4. Coordinate building egress lighting with site lighting such that egress lighting is provided to the public way during power outages.

5.13 TOILET, BATH, AND LAUNDRY ACCESSORIES

1. All new construction and renovation of restroom facilities shall include wall-mounted, high-efficiency hand dryers and at least one “no touch” paper towel dispenser in each restroom.
2. All new construction and renovation of restroom facilities shall include wall mounted soap dispensers that are installed within 5' of sink. Sink mounted dispensers shall not be installed.
3. All consumable dispensers (e.g., soap dispensers, paper towels, and toilet tissue) shall be coordinated with current vendor.
4. Accessibility-compliant grab bars shall be stainless steel.
5. Provide wall-mounted shelving in restrooms to accommodate books, backpacks, etc.
6. Mirrors shall be vandal proof with stainless steel frame.
7. Student rooms in Residence Halls shall have stainless steel medicine cabinets.

5.14 INTERIOR STAIRWAYS

Metal and wood stairways, treads, nosings, and railings are acceptable. Rubber stair treads are acceptable.

The leading edge (intersection of the tread and riser) of stairways shall be perpendicular to the direction of travel. Stairways with the direction of travel at an angle to the leading edge of the stairway are not acceptable.

See DCSM section 3.1.1 for fall protection requirements regarding handrails for stairways.

5.15 INTERIOR FINISHES

OUP shall be consulted on:

1. Exposed ceilings – Areas shall be uniformly painted; piping and other mechanical or plumbing systems shall be aligned in orderly and uniform way at right angles.
2. Resilient tile flooring
3. Carpet tile
4. Interior painting – Lobby and front-of-house public areas shall use colors consistent with the University's branding guidelines. The intent of the color restriction is to avoid short-term trends that will quickly appear out-of-date.

5.15.1 General Finishes

1. The preliminary selection of interior finish materials shall take place during the design development phase. Informal discussions of finish materials appropriate to the intended project use shall precede a formal Interior Design Presentation of interior finish boards by the A/E consultant's interior designer with design input and approval from CC and OUP. Virginia Tech must then approve the color selections of all finishes.
2. The interior finish boards and the interior finish binder set shall include representative samples of adequate size to visualize colors and patterns. Particular attention shall be given to finishes in public spaces. The finish boards shall be labeled and keyed sufficient to cross reference to a floor plan presentation and finish legend for easy reference. Templates for the boards and the binders will be provided by CC.
3. Interior finish selections shall be high quality, durable materials, with a strong preference for Virginia based and/or regional manufacturers. Specialty or higher end finishes may be acceptable for public spaces as deemed appropriate during the informal discussions in design development.
4. Avoid imported materials. Avoid custom materials and choose from manufacturers' standard offerings as future replacement or matching is an unnecessary premium in cost.

5.15.2 Wall Finishes

1. General: The use of wallcovering and wall panels provides a durable, cleanable surface that adds aesthetic and/or acoustical properties. Wallcoverings shall not be used in areas that are subject to moisture and shall be used economically.
2. Design Considerations: The use of wallcovering and wall panels manufactured with high recycled post-consumer and/or post-industrial content is encouraged. The selection of zero or low volatile organic compound (VOC) primers and adhesives will help eliminate indoor air quality problems.
3. Products: Suitable selections include, but are not limited to:
 - a. Vinyl Wallcovering with a mostly smooth surface for scrubbing purposes
 - b. Acoustical Wall Panels may be wood, laminate, or fabric
 - c. Tile and Tile Grout
 - i. Zero or low VOC mortars, grout, and sealants shall be used.
 - ii. Epoxy grout shall be used in all kitchens and restrooms/showers.
4. Wall tile may be ceramic, porcelain, or glass.

5. You may use a variety of tile sizes.
6. All tile patterns must follow manufacturer guidelines. For example, large format tiles (12" × 24" and above) must be installed in a 1/3 offset and grout joints typically 1/8" according to TCNA recommendations.

5.15.3 Painting and Coating – Interior Painting

1. Volatile Organic Compounds (VOCs): Products used shall not emit VOCs as defined by the EPA, measured by weight in grams/liter and listed herein:
 - a. Semi-gloss and gloss – 0 to 50 grams/liter VOC - Low VOC Paint
 - b. Eggshell – 0 to 5 grams/liter VOC - Zero VOC Paint.
2. Formulation: do not use products that contain formaldehyde, halogenated solvents, aromatic solvents, or heavy metals.
3. Acceptable manufacturers meeting the above specifications include:
 - a. Benjamin Moore & Co.
 - b. The Sherwin-Williams Company
 - c. PPG Architectural Finishes, Inc.
4. Paint all interior and exterior exposed conduit, boxes, and supports except in electrical rooms, mechanical rooms, and janitor closets.
5. Additional Residence Hall painting requirements:
 - a. All walls shall be primed with latex primer and shall be back rolled with a 1/2" nap roller.
 - b. Room paint shall be in accordance with this section and shall be white semi-gloss latex and shall be back rolled with a 1/2" nap roller.
 - c. All paint shall be applied with one coat primer and two coats of finish as a minimum or to cover as needed for colors.
 - d. All accent wall paint colors shall be latex and shall be back rolled with a 1/2" nap roller.

5.15.4 Floor Finishes

1. See DCSM section 5.18 for laboratory design guidelines.
2. Discuss finish requirements with VT Housekeeping during the selection process.
3. Flooring requirements for Resident Halls:
 - a. Student rooms – Luxury Vinyl Tile (LVT).
 - b. Laundry Room – Vinyl Composition Tile (VCT) or monolithic seamless floor.
 - c. Cove Base – 4" rubber. Color is application specific.

4. Elevator cab floors shall be carpet squares or rubber floor tile with “lo-disc” raised circular design for a non-slip surface (acceptable manufacturers for rubber include Roppe Rubber Co., Johnsonite, and Musson Rubber Co.).
5. Design Considerations: The use of flooring manufactured with high recycled post-consumer and/or post-industrial content is encouraged. The selection of zero or low VOC primers, adhesives, and sealants will help to eliminate indoor air quality problems.

5.15.4.1 Floor Tile

1. Floor tile shall be a through-color/color body product. All products shall be top quality, be easy to clean and maintain, and have a DCOF of at least 0.42. Some applications may require a higher DCOF depending on use, expected traffic and wear, contaminants, maintenance, and manufacturer guidelines. Install a coordinating cove tile base where possible.
2. You may use a variety of tile sizes; however, a 6" × 6" or smaller must be used on floors that slope to a drain.
3. Wall tile may be ceramic, porcelain, or glass.
4. All tile patterns must follow manufacturer guidelines. For example, large format tiles (12" × 24" and above) must be installed in a 1/3 offset and grout joints typically 1/8" according to TCNA recommendations.

5.15.4.2 Resilient Flooring

The use of resilient flooring provides an economical solution for flooring in a variety of areas, including but not limited to, corridors, work rooms, copy rooms, offices, and classrooms. Resilient flooring for laboratories shall meet project criteria for chemical resistance and maintainability. When resilient flooring is used in restrooms or food service areas it shall be properly protected/sealed to ensure it is waterproof.

1. Products include but are not limited to:
 - a. Luxury Vinyl Tile (LVT) or Sheet Flooring: See DCSM section 5.15.4.3, Resilient Tile Flooring, for further requirements.
 - b. Rubber Flooring
 - c. Vinyl Composite Tile
 - d. Linoleum
 - e. Rubber Base: Specify rubber cove base, 4 inches high. Avoid the use of preformed interior and exterior corners.
2. Resilient stair treads, risers, and nosings are acceptable.

5.15.4.3 Resilient Tile Flooring

1. Products:

a. LVT shall meet the following minimum requirements:

Construction (Plank and Tile)	Luxury Vinyl Plank or Tile with micro bevel edges
Overall Thickness (Plank and Tile)	0.098 inches (2.5 mm)
Wear layer Thickness (Plank and Tile)	20 mils
Finish Layer	Urethane aluminum oxide topcoat cured by ultraviolet process with minimum 10 year warranty
Static Load Limit	750 psi
Specification (ASTM 1700)	Class 3, Type B
Heat Stability (ASTM F-1514)	Passes
Stain Chemical Stability (ASTM F-925)	Passes
HUD/FHA Requirements	Exceeds
Flooring Radiant Panel (ASTM E-648)	≥ 0.45 watts/cm ² , Passes (Class 1)
NBS Smoke Chamber (ASTM E-662)	<450 – Passes

b. Flooring shall meet composition, size, thickness, squareness, flexibility, dimensional stability, and resistance to chemicals requirements of ASTM F 1700, “Standard Specification for Solid Vinyl Tile,” Class III, Type B - Embossed Surface.

2. Accessories:

- a. For patching, smoothing, and leveling monolithic subfloors (concrete, terrazzo, quarry tile, ceramic tile, and certain metals), provide Portland Cement-based Underlayment. No gypsum products.
- b. For sealing joints between the top of wall base or integral cove cap and irregular wall surfaces such as masonry, provide plastic filler applied according to the manufacturer’s recommendations.
- c. Provide transition/reducing strips tapered to meet abutting materials.
- d. Provide threshold of thickness and width as shown on the drawings.
- e. Provide resilient edge strips of width shown on the drawings, of equal gauge to the flooring, homogenous vinyl or rubber composition, tapered or bullnose edge, with color to match or contrast with the flooring, or as selected by the architect from standard colors available.
- f. Provide metal edge strips of width shown on the drawings and of required thickness to protect exposed edges of the flooring. Provide units of maximum available length to minimize the number of joints. Use butt-type metal edge strips for concealed anchorage, or overlap-

- type metal edge strips for exposed anchorage. Unless otherwise shown, provide strips made of extruded aluminum with a mill finish.
3. Quality Assurance:
 - a. Examine subfloors prior to installation to determine that surfaces are smooth and free from cracks, hole, ridges, and other defects that might prevent adhesive bond or impair durability or appearance of the flooring material.
 - b. Inspect subfloors prior to installation to determine that surfaces are free from curing, sealing, parting and hardening compounds; residual adhesives; adhesive removers; and other foreign materials that might prevent adhesive bond. Visually inspect for evidence of moisture, alkaline salts, carbonation, dusting, mold, or mildew.
 - c. Report conditions contrary to contract requirements that would prevent a proper installation. Do not proceed with the installation until unsatisfactory conditions have been corrected.
 - d. Failure to call attention to defects or imperfections will be construed as acceptance and approval of the subfloor. Installation indicates acceptance of substrates with regard to conditions existing at the time of installation.
 4. Finishing of Floors: A/E shall consult with VT Housekeeping and OUP in design and specify if the Contractor is to finish the floors.
 5. Extra Stock: Furnish 5% additional yardage of each resilient floor type required; extra yardage is over and above any overage provided by manufacturer. Normal manufacturing overage not to exceed 10% for under 1,000 yards. Not to exceed 5% for over 1,000 yards. Consult with VT PM to determine the required quantity of attic stock and determine where it will be stored. Deliver to the University uncut in clearly marked dust-proof packages prior to commencement of work; store where directed.
 6. Warranties: All LVT shall have a minimum warranty of 10 years.

5.15.4.4 Carpet Tile

The use of carpet provides an economical solution for flooring in a variety of areas, including but not limited to offices, conference rooms, and classrooms. Specify top quality aesthetically pleasing products, with characteristics of cleanability and acoustical properties. Color selections shall minimize the showing of dust and/or footprints. Avoid very light, very dark, or solid color carpeting. Avoid the use of cut pile carpeting, instead selecting loop or cut and loop combination for increased durability. High

quality carpet is a long lasting, durable product that is easy to maintain over its lifetime. The use of carpet tiles allows damaged or stained tiles to be replaced individually.

1. Products:

a. Carpet shall meet the following minimum requirements:

Construction:	Tufted – Loop or Cut/Loop (Non-Ortho Phthalate Construction)
Face Fiber:	<ol style="list-style-type: none"> 1. Type 6,6 Nylon preferred, but not required, in heavy traffic areas. The basis of design for type 6,6 nylon carpet shall be Stainmaster Antron. 2. Type 6 Nylon for lesser trafficked areas 3. Fibers will contain a soil and stain resistance
Dye Method:	Solution/Yarn dyed
Gauge:	5/64 preferred, minimum of 1/12 required
Stitches Per Inch:	9 or more
Density:	5,000 or higher
Tufted Yarn Weight:	22 oz./sq. yd. or higher (the higher the better)
Primary Backing:	100% Woven Synthetic
Recycled Content:	At least 15% Pre-Consumer
Size:	Modular, Tile, Sizes vary
Static Control:	< 3.0 kV when tested under AATCC 134
Flammability:	<ol style="list-style-type: none"> 1. DOC-FF-1-70 Pill Test: Passes 2. Floor Radiant Panel: Meets NFPA Class 1 when tested per ASTM-E-648 glue down 3. NBS Smoke Chamber: Less than 450 Flaming Mode. Per ASTM-E-662
Color Fastness:	<ol style="list-style-type: none"> 1. Lightfastness: AATCC 16E-1982 – Dark color: Gray scale rating of 4 or better after 160 standard fading hours as compared to AATCC Gray Scale for evaluation change in color 2. Ozone and Gas: AATCC 129-1981 – Rating 3 or better per color AATCC transference scale
Moisture Barrier:	<ol style="list-style-type: none"> 1. Passes Moisture Impact at 10,000 cycles 2. Passes British Spill Test
Indoor Air Quality:	Manufacturer must demonstrate that carpet is certified under the CRI Green Label Plus Program
NSF 140 Certification:	SCS Sustainable Choice Gold

b. Pattern and Color: Understanding the importance of pattern and color for aesthetics, as well as appearance retention and maintainability, OUP reserves the right to reject any product or manufacturer based solely on pattern and color considerations.

2. Quality Assurance:

a. Dimensions shown on drawings are approximate. It is the flooring contractor’s responsibility to verify all dimensions and job site conditions; order sufficient yardage to fully carpet areas as indicated

- and to fill overage requirements as specified. No substitutions shall be permitted to make up for any shortage of material in overage or in carpet to be installed.
- b. Flooring contractor shall be totally responsible for the accuracy of his measurements of total yardage, individual floor yardage, and dye lot yardage requirements; no additional compensation shall be allowed for shortage of materials.
 - c. Dye Lots: All carpet of the same type in continuous areas shall be from the same dye lots. Transition from one dye lot to another shall be detailed on shop drawings and approved by OUP.
 - d. Inspect surfaces to receive carpet and verify that all such work is complete to the point where this installation may properly commence. In the event of a discrepancy, notify construction manager. Do not proceed with the installation in areas of discrepancy until all such discrepancies have been fully resolved. Start of carpet installation indicates acceptance of subfloor conditions and full responsibility for completed work.
3. Extra Stock: Furnish 5% additional square yardage of each carpet type required for renovations and verify the amount of additional square yardage required with VT PM for Capital Projects. Extra square yardage is over and above any overage provided by manufacturer. Normal manufacturing overage is not to exceed 10% for under 1,000 square yards and not to exceed 5% for over 1,000 square yards. Consult with VT PM to determine the required quantity of attic stock and determine where it will be stored. Deliver to the University uncut in clearly marked dust-proof packages prior to commencement of work; store where directed.
 4. Warranties:
 - a. All carpet tile shall have a Limited Commercial Lifetime Warranty. The warranty should protect against product failure covering all costs including freight, labor, and material for the following:
 - i. Edge ravel
 - ii. Back delamination
 - iii. Superior tuft bind in high traffic environments, wet or dry
 - iv. Static protection as stated above
 - v. Moisture barrier – Pre-Coat and backing
 - vi. Wear – No more than 10% of face tarn loss
 - vii. Adhesive failure
 - b. Cationic Stain Resistance – Stain resistance properties must be permanent and not removable by commercial cleanings or abrasive

wear. Under GSA requirements, stain resistant carpets must score no less than 8.0 (10.0 is the best) on the AATCC Red 40 Stain Scale. Test sample must first be exposed to 100 revolutions on the Taber Abrader (1,000-gram weight per H-18 wheel) and then abraded area must be stain tested using AATCC test method 175. Topical stain resistance treatments will not be acceptable. Stain resistant properties must be inherent and warranted for fifteen years.

- c. Bleach Resistance – Carpet products will resist color loss from diluted bleach applications for a period of fifteen years from the date of original installation. Diluted bleach applications means spills of splashes on the carpet of diluted bleach solutions (10% or less) of the type normally used for cleaning or disinfecting purposes.
5. Environmental Attributes – LEED Criteria
 - a. Carpets should be selected to help the project achieve the goal LEED status.
 - b. Carpets and adhesives must meet the Low Emitting Materials standards as outlined in the USGBC LEED criteria.
 - c. End of Life Reclamation: It is preferred that carpet tile have an existing methodology actively in place for landfill diversion.
 6. Accessories:
 - a. Adhesives: Waterproof, non-flammable carpet adhesive recommended and approved by carpet manufacturer in writing for compatibility with carpet backing; have no calculated VOCs, be non-flammable, and meet the criteria of the CRI Green Label Plus Certification Program. Safety Data Sheets (SDS) and samples are required on product used. Adhesive must have Lifetime Bond Warranty from manufacturer.
 - b. Miscellaneous Materials: As recommended and approved in writing by the manufacturer of carpet, and selected by the flooring contractor to meet project circumstance and requirements.

5.15.4.5 Rugs and Mats

Recessed walk-off mats or grates shall be provided at all primary entrances to buildings. Primary preference is to use walk-off carpet.

5.15.5 Ceiling Finishes

Ceilings may be exposed, have acoustic properties, contain decorative elements, be constructed of GWB, etc.

5.15.5.1 Acoustical Tile Ceilings

1. Suspension systems shall have exposed tee profile fabricated of hot galvanized steel with baked on painted finish. All spaces using acoustical ceiling tile (ACT) must have a minimum NRC rating of 0.70 and a minimum CAC rating of 35, unless otherwise approved by OUP. Approved manufacturers include, but are not limited to:
 - a. Armstrong
 - b. USG
 - c. CertainTeed
2. Products:
 - a. Acoustical Ceiling Tile (ACT): Standard 2' × 2' × 5/8" Tegular (on a project-by-project basis 2' × 4' × 5/8" – discuss with OUP and Engineering Operations), mineral fiber panels, for use in offices, classrooms, conference rooms and corridors.
 - b. Acoustical Ceiling Tile (ACT): Specialty 2' × 2' × 5/8" Tegular (on a project-by-project basis 2' × 4' × 5/8" – discuss with OUP and Engineering Operations) for use in wet areas and laboratories to resist moisture, steam and chemicals.
 - c. Suspended Grid: Heavy Duty (HD) or Intermediate Duty (ID) exposed tee grid system with 15/16" standard grid dimension or 9/16" narrow grid dimension. Specify fire rated grid if required.
3. Thin line grid shall not be used on campus.

5.16 FURNISHINGS

5.16.1 Common Work Results for Furnishings

1. Furniture shall meet ANSI/BIFMA standards.
2. Universal Design shall be considered in the following aspects when selecting furniture:
 - a. Equitable Use – The design is useful and marketable to people with diverse abilities.
 - i. Provide the same means of use for all users; identical whenever possible; equivalent when not.
 - ii. Avoid segregating or stigmatizing any users.
 - iii. Provisions for privacy, security, and safety should be equally available to all users.
 - iv. Make the design appealing to all users.

- b. Flexibility in Use – The design accommodates a wide range of individual preferences and abilities.
 - i. Accommodate right- or left-handed access and use.
- c. Simple and Intuitive Use – The design is easy to use and understand, regardless of the user’s experience, knowledge, language skills, or current concentration level.
 - i. Eliminate unnecessary complexity.
 - ii. Be consistent with user expectations and intuition.
- d. Perceptible Information – The design communicates necessary information effectively to the user, regardless of ambient conditions of the user’s sensory abilities.
 - i. Maximize “legibility” of essential information.
 - ii. Differentiate elements in ways that can be described (i.e., make it easy to give instructions or directions).
 - iii. Provide compatibility with a variety of techniques or devices used by people with sensory limitations.
- e. Tolerance for Error – The design minimizes hazards and the adverse consequences of accidental or unintended actions.
 - i. Arrange elements to minimize hazards and errors: most used elements, most accessible; hazardous elements eliminated, isolated, or shielded.
 - ii. Provide fail safe features.
- f. Low Physical Effort – The design can be used efficiently and comfortably and with a minimum of fatigue.
 - i. Specify furnishings which allow user to maintain a neutral body position.
 - ii. Use reasonable operating forces.
 - iii. Minimize sustained physical effort.
- g. Size and Space for Approach and Use – The design provides the appropriate size and space needed for approach, reach, manipulation, and use regardless of user’s body size, posture, or mobility.
 - i. Provide a clear line of sight to important elements for any seated or standing user.
 - ii. Make reach to all components comfortable for any seated or standing user.
 - iii. Accommodate variations in hand and grip size.
 - iv. Provide adequate space and infrastructure for the use of assistive devices or personal assistance.

3. During the preliminary design phase, furniture and equipment plans are submitted to demonstrate the functional use of space. Virginia Tech's design review process includes review and input on these floor plans by OUP and the end user. These plans shall be used as the basis for locating receptacles, switches, data outlets, lighting, etc., during the remainder of the design process.
4. Based upon the above referenced floor plans, the A/E shall provide outline specifications and a budget cost estimate reflecting appropriate vendor pricing (discounts, freight, delivery, installation) for Virginia Tech's use.
5. The A/E contract may be amended to include professional interior design services related to furniture selection and procurement or Virginia Tech may enter into a separate interior design contract defined by the VT CPSM.
6. The design and procurement process will be thoroughly defined for project. Under the terms of the interior design contract particular attention shall be given to furnishings in public spaces.
7. All furniture plans shall be labeled and keyed sufficiently to cross reference to specifications and procurement documents for easy reference.
8. Plan layouts and furniture selections with respect to maximizing daylight and access to views for all building occupants. Consider lower panels and glazed panels for systems workstations. Avoid the use of panels that are 80 inches or higher that may obstruct adequate air flow and daylight penetration.
9. Furniture items selected shall emit zero or very low amounts of VOCs to eliminate problems associated with off-gassing and indoor air quality. Fabrics shall be flame retardant.
10. Furniture and upholstery selections shall include the following design strategies wherever possible:
 - a. Post-consumer and/or post-industrial recycled content.
 - b. Products with a minimum 10-year warranty; greater than 15 years is preferred.
 - c. Materials that have been extracted locally or regionally. Furniture selections shall be high quality, durable items that are manufactured within a 500-mile radius of the project site, with a preference for manufacturers with established environmental policies in place.
 - d. Certified wood products or sustainable species from abundant, local sources.
 - e. Rapidly renewable materials (such as straw, wheat, sunflower board).
 - f. Energy efficient task lighting.

- g. Products/materials free of formaldehyde, halogen, heavy metals, polyvinyl chloride, chlorine, plasticizers, antimony, harmful dyes, and topical treatments.
- h. Products/materials that are safely disposable, recyclable, or biodegradable.
- i. Fabrics that are durable, minimum 80,000 double rubs, 100,000 preferred.
- j. Fabrics that are antibacterial and easy to clean.
- k. The basis of design to provide permanent stain protection for fabrics shall be NanoTex™ finish or equal. Equivalent stain protection shall ensure that spills bead and roll off preventing stain from absorbing into the fabric. The finish shall be applied at molecular level, adhered to fibers of the fabric and last the lifetime of the fabric.
- l. The use of leather should be avoided. If the use of leather is approved by the University, specify only vegetable tanned leather.

5.16.2 Casework

Casework may be wood, wood veneer, or clad in a plastic laminate (preferred). Acceptable countertops products include Metal, Plastic Laminate (P-LAM), Glass, Stone, Solid Surface, and Quartz.

5.16.3 Storage Specialties

1. All residence halls shall have a key cabinet with a minimum of 32 keys located somewhere in the common areas of the first floor of the building. Consult with Student Affairs on project specific key cabinet requirements.
2. Housekeeping Supervisor's Office Closets shall have a key cabinet installed with the following requirements:
 - a. Cabinet shall be constructed of a minimum of 20-gauge steel.
 - b. Finish shall be baked on enamel, or an equal approved by University Operations.
 - c. Hinge shall be concealed.
 - d. Lock type shall be keyed.
 - e. Minimum size shall be 12" × 12" × 2".
3. Housekeeping closets shall have:
 - a. A minimum footprint of 8' × 5'.
 - b. Separate hot and cold water utilities. No mixing valves.
 - c. 30" × 30" floor sink, located in the corner of the closet if possible.
 - d. Supply shelves located on at least two walls. Shelves shall be at least 12" deep.

- e. Closet organizer and tool holder.
 - f. At least 4 GFCI electrical outlets.
 - g. Personal locker.
 - h. Wall space to accommodate a cleaning solution dispensing system. The basis of design shall be Diversey J-Fill.
 - i. Floor space to store equipment.
4. Housekeeping Equipment Closets shall be located on the main or first floor. Equipment closets shall have:
- a. A footprint of 12' × 8'.
 - b. Double doors.
 - c. Separate hot and cold water utilities. No mixing valves.
 - d. 30" × 30" floor sink, located in the corner of the closet if possible.
 - e. Supply shelves located on at least two walls. Shelves shall be at least 12" deep.
 - f. Closet organizer and tool holder.
 - g. At least 4 GFCI electrical outlets.
 - h. Personal locker.
 - i. Wall space to accommodate a cleaning solution dispensing system. The basis of design shall be Diversey J-Fill.
 - j. Floor space to store equipment.

5.16.4 Whiteboards

All whiteboards should have a board finish that resists residue or “ghost marks” on the surface after markings have been erased (ceramic steel or equivalent).

Mobile whiteboards should be two-sided and have casters are designed to roll smoothly over carpeted and non-carpeted level floor surfaces. Casters should have a locking mechanism to secure the markerboard in place.

Whiteboards should have the option for a magnetic surface.

OUP will provide requirements for frame finishes and colors for the whiteboards.

5.16.5 Dry Erase Coating

1. Volatile Organic Compounds (VOCs): Low Volatile Organic Compound (VOC) content of less than 50 grams per liter to meet Green Seal™ standards for paints and coatings.
2. Durable, long-lasting surface with 10,000+ scrub cycles and excellent stain removal.

3. Class A rated for fire safety in accordance with ASTM E-84; classified as insignificant flammability hazard by the Hazardous Material Identification System.
4. Level 5 finish required.
5. 10-year warranty minimum.

5.16.6 Residential Furnishings

5.16.6.1 Residential Kitchen Appliances

For Residence Halls: The basis of design for kitchen appliances shall be GE or equal and ADA accessible.

5.16.6.2 Desks and Bedroom Furnishings

Examples below are presented for guidance only. Actual furniture will be selected by project. Consult with Student Affairs about furnishings for resident rooms during project design.

1. Virginia Correctional Enterprises (VCE):
 - a. Period bed ends with springs – Item #3195020000, 36" × 80"
 - b. Period loft kits – Item #319502loft
 - c. Right hand desk – Laminate Top Oak Wood Drawer item #311002traw, 30" H × 40" D × 43" W
 - d. Left hand Desk – Laminate Top Oak Wood Drawer item #311002law, 30" H × 40" D × 43" W
 - e. Dressers – Upper quad item #317202-vtaw, 38" H × 23" D × 29" W
 - f. Wardrobe: Item #31605020002, 35.5" H × 40" W × 25" D, with 2 drawers at the bottom
2. Sauder Education, Desk chair – Sauder Trey Chair Item #VT 33912, 36" H × 27" D × 24" W.

5.16.6.3 Metal Lockers

12" wide full height, shelf and hooks, metal with louver door, handle for installation of personal padlock.

5.17 EQUIPMENT

5.17.1 Foodservice Equipment

For Dining Halls: Kitchen design firms shall be selected by Student Affairs for non-capital renovation projects.

5.17.2 Foodservice Storage Equipment

Specify water cooled units and remote compressors when possible. Consider maintenance access in the design.

5.18 LABORATORY DESIGN

5.18.1 Scope

The following requirements apply to all new laboratory design and construction as well as all laboratory renovations at Virginia Tech. In this context, a laboratory is defined as a space where chemical, biological, or radiological materials are used for research, teaching, or analytical services.

5.18.2 Laboratory Access and Egress Issues

1. Means of Egress

NFPA 45 section 5.4, 2015 and/or OSHA 1910.37 require more than one means of egress be provided where high-hazard research operations (explosion hazards, compressed gas cylinder use, etc.) are anticipated. Clear access to each means of egress must be assured by the design of the research space. However, EHS recommends every laboratory using any hazardous chemicals be designed with more than one means of egress.

2. Flow of traffic

When labs are designed or renovated, the flow of traffic toward the means of egress must take a path of “Diminishing Hazards,” i.e., the hazard presented by the anticipated research operations must diminish in the direction of egress travel. For this reason, lab seating, desks, computer stations and lounge areas shall be located closest to the means of egress, while fume hoods, chemical storage and bench top chemical work stations shall be located farthest from the means of egress (OSHA 1910.37(a)).

3. Aisles

Major aisles shall provide a minimum width of 5 feet to allow for the passage of personnel and equipment safely down the aisles. Major aisles must align in the direction of egress travel. All other aisles shall provide a minimum width of 36 inches unless a greater width can be anticipated from the character of the research that is to be conducted. Consider ADA requirements as part of laboratory design.

5.18.3 Laboratory Safety Equipment

See DCSM section 3.9 for information about laboratory safety equipment.

5.18.4 Building Systems

1. Design strategy: The designer shall ascertain the character of research and operations that are to be conducted in the area. Where emergency power is required, the designer shall investigate alarm systems to alert during power failure.
 - a. Special consideration shall be given to areas where general surface decontamination will be performed using sprayed disinfectants and/or water, where large sources of water will be present (e.g., aquatics and fisheries), and where a higher potential for electric shock may be present. In such areas, ground-fault circuit interrupters and wiring methods approved for damp/wet locations shall be provided as appropriate.
 - b. Bulk chemical storage and dispensing areas shall be designed in accordance with Article 500 of the NEC as either Class I Division 1 or 2 as appropriate for the intended use. A ground bar shall be provided in dispensing areas to facilitate grounding to eliminate electrostatic discharge during dispensing operations.
 - c. Consideration shall be given to providing emergency power for critical research equipment (very low temperature freezers, equipment that protects valuable specimens, hazardous exhaust systems, etc.) as practical within the constraints of the existing building systems and budget. Coordinate with VT PM on project specific requirements.
 - d. If the laboratory operations, require access to significant amounts of refrigeration or below 0 °C materials storage, the designer should consider dedicated low temperature storage rooms or coolers. Emergency power shall be provided these storage areas.
2. Cutoff Switches: Consideration shall be given to providing wall-mounted emergency stop switches in research areas where high-power or high-amperage research operations will be conducted on live electrical systems. Such switches shall be strategically located so that they are readily accessible to the occupants of the space. A lockable disconnect shall be provided in the immediate vicinity of fixed equipment that will be installed if such equipment incorporates multiple sources of energy.

5.18.5 Laboratory Ventilation

1. Ventilation and air balancing:
 - a. For new buildings, air balancing for hoods must be done at the same time as the other mechanical ventilation systems in the building.

- b. Where lab activities involve the use of chemicals, air balance shall be designed to ensure a negative pressure relation between the lab and existing corridors, offices, break rooms and other support spaces.
 - i. One exception to this rule: Bio-safety laboratories may require a positive pressure or equivalent pressure, but these instances must have other containment in place to ensure that airborne pathogens are not allowed to escape into non-lab spaces.
- 2. Laboratory ventilation systems (supply air – velocity and entry into labs):
 - a. Supply system design shall comply with the latest adopted version of NFPA 45, Standard on Fire Protection for Laboratories Using Chemicals.
 - b. For lab spaces, operable windows cannot be relied upon to meet outside air requirements provided by the mechanical code.
 - c. Supply air must be tempered and delivered at a velocity that will not create occupant discomfort.
 - d. Supply air diffusers and grilles must be placed a minimum of 4 feet from the face of any fume hood to prevent losses from the fume hood due to turbulent flow. Where this is not practicable, the diffusers or grilles must have directional flow to minimize air loss/spilling from the hood face.
 - e. Operable windows are not permitted in lab spaces with fume hoods or where lab air change rates are required for occupant safety.
 - f. Transfer ducts are not permitted in laboratory spaces.
- 3. Recirculation of laboratory room air: No laboratory exhaust-air, or air that is potentially contaminated with chemicals or airborne radioisotopes may be mixed and recirculated to non-laboratory spaces.
- 4. Continuous ventilation of chemical labs: All labs that utilize chemicals must be constantly ventilated. This is also true for chemical storerooms, compressed gas storerooms, and central storerooms that are utilized as shipping/receiving areas for chemicals.
- 5. The installation of oxygen sensors is required when large quantities of cylinders containing inert gases or containers containing cryogenic liquid are planned for storage in enclosed spaces where there is the potential to reduce oxygen levels below 19.5%.
- 6. Energy saving set-backs:
 - a. Where the design strategy will use a lower minimum ventilation rate during unoccupied periods, the set-back level may not be lower than 6 air changes per hour unless approval from EHS is obtained. In order to utilize such a system, occupancy sensors which provide full lab coverage must be provided that will bring the ventilation back up to the "occupied laboratory" ventilation rate immediately.

- b. Occupancy sensors shall be ceiling-mounted, hardwired, and utilizing dual technology. In addition, the sensor(s) shall provide complete lab floor coverage at desktop activity (i.e., small movement) and fail in the occupied state (component failure or loss of power).
- c. Maximum ventilation rates are to be established during the design and commissioning processes and be the greater of that required for cooling/heating loads or make-up air to maintain desired lab offsets.
- d. Laboratory air controllers for both supply and exhaust air terminal devices shall have the capability to accurately control to a minimum setpoint equivalent to four air changes per hour, in the event this lower value is approved or allowed in the future.
- e. Laboratory ventilation systems are to be designed in accordance with Classification of Laboratory Ventilation Design Levels, ASHRAE TC 9.10 2018 or current edition. It is incumbent upon the project design team to invest in an understanding of not only the immediate program goals for laboratory spaces but also the long-term needs for program flexibility. Such discussions shall involve members of the project planning committee, Facilities Services, and EHS.
- f. Energy setbacks that allow a reduction in hood face velocity rates to less than 60 feet per minute (linear feet per minute) are not allowed.
- g. Energy setbacks that allow a reduction in hood face velocity rates to between 60 LFM and 80 LFM are not allowed except when occupancy sensors, installed and confirmed to provide full lab coverage, are used to establish unoccupied modes for the lab. In addition, fume hoods must be rated and tested to contain vapors at the proposed reduced face velocity. It also must be confirmed that the unoccupied ventilation level does not reduce ventilation levels to fewer than 6 air changes per hour. Reductions to fewer than 6 air changes per hour require approval from EHS.
- h. Proximity sensors (those mounted to the face of the hood) are not allowed nor are face velocity setpoint reductions in an occupied lab.

5.18.6 Laboratory Exhaust

5.18.6.1 Exhaust Design

- 1. Auxiliary supplied air hoods are not to be used unless special energy conditions or design circumstances exist and can only be used with the approval of EHS.

2. Commingling or mixing of general laboratory exhaust and exhaust directly from fume hoods is allowable as long as it is accomplished in compliance with any applicable building and life safety codes.
3. Exhaust Stack Discharges: Dispersion modeling shall be conducted when required by ASHRAE TC 9.10, or as directed by the University, and exhaust stack discharge shall be in accordance with ASHRAE Handbook - HVAC Applications and ANSI/AIHA Z.9.5, current editions. Exhaust stack discharge shall be at least 3,000 feet per minute except as allowed by ANSI/AIHA Z9.5 and when approved by EHS.
4. Where fume hoods and general laboratory room exhaust streams are combined, the duct shall be round stainless steel (Type 316) ductwork with welded seams and flanged or welded connections. The stainless steel ductwork shall be run from the point of collection (hood connection[s] or room exhaust grille[s]) to the main riser for that portion of the building; exhaust ductwork may be manifolded as permitted by code. The main duct riser may be constructed of stainless steel or anti-corrosion coated galvanized or other suitable materials. Where exhaust streams are not combined, only the fume hood exhaust ductwork need be run in stainless steel, coated, or other suitable anti-corrosion materials.
5. No heat recovery wheels (or any other technology which does not completely separate the exhaust and intake airstreams) will be considered for energy recovery building exhausts which handle fume hood exhaust, whether combined or not.
6. Variable air volume control dampers controlling the exhaust flow from fume hoods and general room exhaust shall fail OPEN upon loss of control power or control air.
7. In the event of a loss of power to the building, provisions need to be made by the Engineer to maintain negative pressure without causing excessive negative pressure in necessary lab spaces while allowing occupants safe egress of building and protect the mechanical equipment from nuisance freezing events. Coordinate specific requirements with EHS through the VT PM.
8. Regardless of the type of fan used the vendor shall certify dispersion performance of all fume hood and hazardous exhaust systems based on as built conditions (with the system running in a controlled mode and design conditions too).
9. All laboratory exhaust air ducts shall be pressure tested, documented, and results submitted to the VT PM.

5.18.6.2 Chemical Fume Hoods

1. Chemical fume hood exhaust
 - a. No fume hood may exhaust out of windows, through side-mounted louvers or other building orifices until reaching the roof.
 - b. Laboratory exhaust containing chemicals must be under negative pressure to the point of discharge at the roof.
2. Chemical fume hood exhaust fans
 - a. All new exhaust stacks for fume hood exhaust shall be a high plume dilution type laboratory exhaust fan.
 - b. All laboratory fans shall be direct drive. Belt driven fans are not permitted.
3. Fume hood testing
 - a. All hoods shall be ASHRAE 110 factory-tested before installation.
 - b. All newly installed, renovated, or relocated hoods shall be commissioned to ensure proper operation prior to use by laboratory personnel. All hoods shall be ASHRAE 110 as-installed tested before use. Tracer gas containment tests shall be conducted per ANSI Z9.5-2012.
 - c. Face velocity shall be verified for all hoods installed during commissioning and a sticker shall be placed on the front of the hood frame before the hoods can be used by lab occupants.
 - d. EHS must be notified of all new hood installations and all commissioning chemical fume hood testing reports shall be provided to EHS.
4. Minimum airflow velocity requirements: Face velocity must be in the 80 to 120 LFM range at the safe operating sash height as set by the manufacturer unless permission for other velocities is approved by EHS.
5. Certification: A label of certification must be placed on each hood by the authority having jurisdiction before occupation of all new labs or before use of all newly installed hoods.
6. Energy Setbacks: See DCSM section 5.18.5.

5.18.6.3 Chemical Fume Hood Design

1. General
 - a. All equipment shall be installed per manufacturer's recommendations.
 - b. Chemical fume hoods and its associated ductwork and fans shall be selected for each application with consideration of the actual and potential use in mind.

- c. Submittals for all chemical fume hoods and bio-safety cabinets shall be provided to EHS for approval prior to purchase of equipment.
2. Automatic sash closure devices are not permitted.
3. Hoods used with flammable materials: Hoods and ductwork associated with work involving flammable materials shall be constructed completely from non-combustible materials. A lip shall be present inside of the hood to prevent the escape of material in case of spill.
4. Toxic gas cabinets: Gas cabinets for toxic or highly toxic gas cylinder storage shall comply with Chapter 50 of the Virginia Statewide Fire Prevention Code regardless of the quantity of gas stored or used.
5. Perchloric hoods: Perchloric hoods are required when perchloric acid of any concentration is heated or >72% perchloric acid solutions are used. Perchloric hoods shall be constructed to allow for a wash-down of the ductwork. This system shall be designed to activate automatically, periodically, and manually. The ductwork for perchloric hoods shall not be manifolded and must exhaust directly to the roof.
6. Radioisotope hoods: Radioisotope hoods shall be constructed so that the surfaces are seamless and impermeable to solvents. Where the radioisotope use requires that the exhaust be filtered before being discharged, the filters shall be positioned for ease of access. The VT EHS Radiation Safety Officer must approve all radioisotope hoods.
7. Fume hood flow-rate alarms
 - a. Every new fume hood installation shall have an audible and visual alarm, warning of unsafe airflow and/or to indicate to the user when the airflow deviates from the set point.
 - b. The alarm shall be readily visible to the user during use of the fume hood.
 - c. The design of the alarm should ensure that only authorized persons are able to adjust the set point.
 - d. For new buildings and capital renovations and where feasible on non-capital renovations, the alarm shall remain functional in the event of loss of main electrical power. Alarms shall be connected to a backup generator; battery back-ups are not allowed.
8. Fume hood location: No lab design or lab renovation shall allow for fume hoods to be located within 10 feet of egress doors from the area except as permitted by EHS. Where hoods are located within 10 feet of an egress door, a secondary means of egress must be provided in a path of diminishing hazard unless otherwise permitted by EHS.

9. Fume hood diversity
 - a. Fume hood diversity, as used in ventilation design, refers to designing and operating a system (such as hoods on a plenum) at a lesser capacity than the sum of the existing parts (hoods) when running at peak demand. There may be opportunities to design research buildings to accommodate less than 100% diversity. Each of these design strategies must be visited on an individual basis.
 - b. Where the building or renovation is designed for the academic lab rather than the research lab, 100% diversity should be considered. This subject shall be visited early in the design and construction planning meetings/process.

5.18.6.4 Other Laboratory Exhaust Devices

1. Local Exhaust Ventilation
 - a. In general, the design of canopy hoods and related local exhaust systems shall comply with Industrial Ventilation, A Manual of Recommended Practice, current edition, American Conference of Governmental Industrial Hygienists, or other accepted industry standard.
 - b. Canopy hoods shall not be used to control exposure to chemical, dust or fume hazards unless such processes are enclosed and employee exposure will not occur. Canopy hoods may be used to control the release of heated gases or vapors which do not present objectionable odors, health risks, or exposure issues of concern. The hood design and capture velocity must be sufficient to capture the contaminants. Testing of these hoods to ensure performance must be performed and documented.
 - c. Local exhaust ventilation systems incorporating snorkels, flanged openings and similar intake openings may be used where it is inefficient or impractical to use a conventional fume hood. These must be installed per manufacturer specifications. Where used, these hoods must be tested for exhaust capacity and the results documented during commissioning.
2. Ductless fume hoods

Ductless fume hoods shall not be used unless reviewed and approved by EHS. Where unknown chemical quantities, materials, or flammable liquid and/or volatiles in large quantities are used in the laboratory, the ductless hood will be prohibited.

5.18.7 Chemical Storage

1. Flammable storage cabinets
 - a. Cabinet design
 - i. Flammable storage cabinets must have approval by a nationally recognized testing laboratory such as UL.
 - ii. Flammable storage cabinets may be under counter, installed under the fume hood, or free standing.
 - b. Venting cabinets
 - i. If the cabinet is vented to a local exhaust system, the system must be designed to accommodate this additional volume of exhaust air. The material used to ventilate the cabinet must be non-combustible and a fume hood cannot be the method of ventilation for cabinets that are not integral to the fume hood. Chemical cabinets built into the base of fume hoods may be vented directly to the hood.
 - ii. When venting chemical cabinets, the venting material must be of equal or greater fire resistance than the cabinet itself – regardless if the cabinet is used for flammable storage. Exhaust from chemical storage cabinets may not be mixed via (plenum) ductwork with flammable storage exhaust ventilation until the vent lines have reached the major ventilation duct.
 - iii. When a flammable cabinet is ducted and exhausted directly to a hazardous exhaust system, a flash-back arrestor must be installed at the exhaust bung.
2. Chemical storage cabinets
 - a. Chemical storage cabinets must have approval by a nationally recognized testing laboratory such as UL. The cabinets may be fixed under fume hoods, counter mount or free standing.
 - b. Shelving must be of a chemically resistant material.
3. Chemical storage rooms

Where an entire room is dedicated to chemical storage, special considerations must be taken for the worst-case scenario. The following specifications are for a typical flammable storage room:

 - a. The room must be sprinkler protected.
 - b. The room must have floor dikes and sealed drains, where applicable. The dikes must be of sufficient depth to capture any foreseeable spills.
 - c. Floor seams must be sealed. It is preferred that monolithic construction with seals from wall to floor is used in all chemical storerooms. Floor

sealant shall be installed as an integral cove base and shall extend 4” above the floor.

4. Waste accumulation areas
 - a. EHS prohibits the designation of waste accumulation rooms or areas in new designs.
 - b. Designs shall include consideration for an area within each lab for placement of active and storage of full waste accumulation containers.

5.18.8 Laboratory Furnishing

1. Lab Shelving and Benchtops
 - a. Shelving/benchtops in chemical laboratories must be chemically impervious, and of fire resistant construction. Wooden shelves shall not be used where chemicals may be stored unless coated with a chemically resistant, fire resistant surface.
 - b. Shelving for radioisotope labs must be impervious to reagent spills and joints must be sealed. Stainless steel or black epoxy resin shelving materials are preferred.
 - c. Shelving must provide adequate containment to prevent accidental tipping or spilling of stored materials. Where shelves are located in open lab-spaces, this would include such designs as lips on shelves, and dividers on shelves that face two separate aisles.
 - d. Shelving and bench tops are to be designed to assure easy access by personnel.
2. Flooring
 - a. All lab facilities are to be designed to facilitate cleaning and decontamination. Carpeting shall not be installed in laboratories.
 - b. Wet labs must have chemical resistant covered flooring.
 - c. Moderate and high-risk facilities must have floors that are designed to be easily cleaned and that are impervious to reagent spills. These floors must be seamless, sealed seamed, or of monolithic construction with curved floor-to-wall junctures to facilitate cleaning. Wet-chemistry labs, as well as all radioisotope labs and BL2 facilities, shall be defined as moderate or high-risk facilities.

5.18.9 Biosafety Laboratory Design

1. Laboratory doors must be self-closing and have locks.
2. Laboratories must have a sink for hand washing. The sink may be manually, hands-free, or automatically operated. It should be located near the exit door.

3. The laboratory must be designed so that it can be easily cleaned and decontaminated. Carpets and rugs in laboratories are not permitted.
4. Laboratory furniture must be capable of supporting anticipated loads and uses.
5. Spaces between benches, cabinets, and equipment should be accessible for cleaning.
 - a. Bench tops must be impervious to water and resistant to heat, organic solvents, acids, alkalis, and other chemicals.
 - b. Chairs used in laboratory work must be covered with a non-porous material that can be easily cleaned and decontaminated with appropriate disinfectant.
6. If biosafety cabinets (BSCs) are required for work they must be installed so that fluctuations of the room air supply and exhaust do not interfere with proper operations. BSCs should be located away from doors, windows that can be opened, heavily traveled laboratory areas, and other possible airflow disruptions. All biosafety cabinets must be installed per manufacturer's instructions.
7. If a central vacuum line is installed it must be protected with High Efficiency Particulate Air (HEPA) filters, or their equivalent which are placed between the laboratory and the pump. These filters may be installed in each lab.
8. An eyewash station must be readily available.
9. Mechanical ventilation systems must provide an inward flow of air without recirculation to spaces outside of the laboratory. The lab spaces must be under negative pressure with respect to the surrounding hallways or common areas.
10. HEPA filtered exhaust air from a Class II, Type A2 Biosafety cabinet can be safely re-circulated back into the laboratory environment if the cabinet is tested and certified at least annually and operated according to manufacturer's recommendations. BSCs can also be connected to the laboratory exhaust system by either a thimble (canopy) connection or a direct (hard) connection. Provisions to assure proper safety cabinet performance and air system operation must be verified. Use of Class II, type B2 cabinets can cause problems with building HVAC balancing and must be approved by EHS prior to installation.
11. A method for decontaminating all biological wastes must be available in the facility (e.g., autoclave, chemical disinfection, incineration, or other validated decontamination method).
12. Any design/construction of a BSL-3 laboratory must consult with the University Biosafety Officer in the early phases of design.

CHAPTER 6 - BUILDING SERVICES

6.1 BUILDING SERVICES GENERAL

6.1.1 Physical Hosting of Computer Servers

A/E shall coordinate with the VT PM and NI&S.

1. Physical security
 - a. Servers should be locked away from physical access/ingress points
 - i. Strong doors and walls
 - ii. Check the door hinges
 1. Are hinge pins on the outside?
 2. Easily removable?
 - b. Should only be accessible by authorized personnel
 - c. Use auditable entry methods (bio-reader, token, or cards). Do not use lock-and-key or combination.
 - d. Security cameras
 - i. Entrances/exits
 - ii. Interior of room: equipment may be difficult in complex or large room
 - e. Environmental alarms (see also 2.a.iv., below)
 - i. Temperature
 - ii. Dampness/Humidity
 - iii. Unauthorized access (particularly remote rooms)
 - f. Are there guards or trained personnel after-hours?
 - g. Other points of entry
 - i. Windows (may also provide visibility to on-screen data)
 - ii. Walls with drop ceilings
 - iii. Space under raised floor
 - h. Server monitoring
 - i. OS server management software
 - ii. "Lights-out" controllers: these can reduce physical access requirements
2. Environmental security:
 - a. See ASHRAE TC 9.9 guidelines:
 - i. Generally allowable from 59 °F to 89.6 °F with 20-80% relative humidity
 - ii. Recommended from 64 °F to 80 °F
 - iii. Non-condensing environment

- iv. Consider using ambient (outside) air to save on infrastructure costs (see Diagram 1 below)
- v. Continuous environmental monitoring
 1. Temp/humidity
 2. Liquid/moisture
 3. Room or cabinet opening

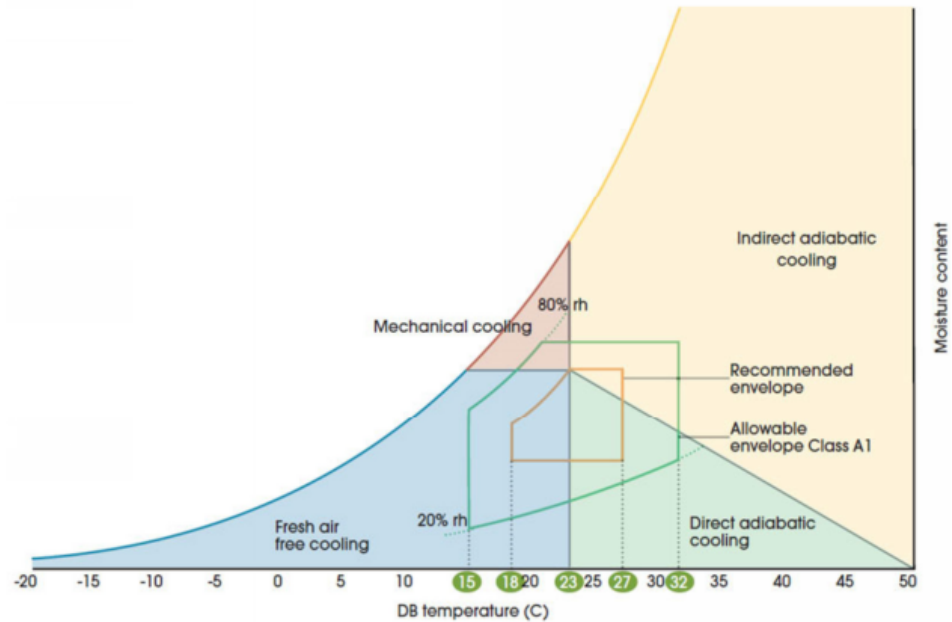

Diagram 1: Use of Ambient Air for Cooling as related to Humidity

- b. Redundancy
 - i. Multiple HVAC units
 - ii. Power loss protection; Uninterruptible Power Supplies (UPS) and generators
- c. Consider airflow (for large/dense installations)
 - i. Aisles and under floor should be clear
 - ii. Heat containment
 - iii. Maintenance impediments; ensure clearance for
 1. Cabinet doors
 2. Cable management
 - iv. Source of cold air: check orientation/fan direction
 1. Often desired to mount network equipment in the back of cabinets
 2. Ensure air flow is not interrupted

- v. Direction of hot air
 1. Blanking panels in racks to prevent wrap-around air
 2. Non-cabinet-mounted/rack mounted equipment allows wrap-around air flow
- 3. Electrical security:
 - a. Document limits; understand requirements for operation
 - i. Branch circuits
 - ii. Panels
 - iii. PDUs
 - b. Filtering – surge arrestors/protectors; often built-in to UPS
 - c. Short-term power outages
 - i. Uninterruptible Power Supplies
 1. Check volt-amperes (VA; apparent power) vs. watts
 2. Most UPS are rated in VAs
 3. Wattage output is less
 4. Most server power supplies are power factor corrected (i.e., documented in watts)
 - ii. Double-conversion UPS vs. standby
 1. Double-conversion = always using DC inverted output
 - (a) Cleaner power
 - (b) More power consumption
 2. Standby = inverter only kicks in when incoming power is abnormal
 - iii. Maintenance
 1. Test or service regularly; quarterly ignition testing/semi-annual load testing
 2. Schedule battery replacements or consider fly-wheels
 - d. Long-term power outages
 - i. Generators are necessary for mission critical applications and services
 1. Maintenance and testing similar to UPS
 2. UPS should be plugged into a generator-backed outlet
 3. Can room HVAC be handled as well?
 - ii. Automated Transfer Switches
 1. How long can the generator carry a full load?
 2. What's the UPS run-time?

- e. Multiple power inputs
 - i. Many servers can have multiple power supplies. Most designs balance power input load between all available circuits on both the utility side and the UPS/generator side.
 - ii. What happens if something fails?
 - 1. Power supply? All of that server's load goes to the other(s).
 - 2. Circuit? All connected loads may re-balance.
 - 3. UPS? If two UPS, can either one handle the load if the other fails?
 - iii. N+1 designs
 - 1. Have 3 or more power supplies
 - 2. How many are needed to keep the server(s) running?
 - 3. Plan UPS, circuits accordingly
- f. How much power do servers use?
 - i. At startup/during nominal load/at peak load
 - ii. Use metered power strips, if possible. This will allow for assessment and measurement.
 - iii. Document actuals and compare with factory ratings
- 4. General/Human Safety:
 - a. Fire suppression
 - i. Gaseous agent: environmental and availability issues
 - ii. No overhead standing water: usually a factor of cost; is equipment and data being protected worth the expense of non-sprinkler system?
 - b. Emergency Power-Off (EPO): only required in certain circumstances
 - c. Emergency lighting
 - d. Exit plan

6.1.2 Facility Control Systems

The University relies on control systems for several critical operations. Any new equipment must be compatible with these systems, using the same communications and programming languages.

These systems are listed below:

1. The Building Automation System (BAS)

The campus-wide BAS is controlled by a Siemens building automation control system. The campus BAS controls all HVAC systems in the buildings and is networked back to the central BAS servers in the Sterrett Complex. VT uses this system to control, monitor, schedule equipment, diagnose mechanical issues, etc. The BAS system will control the chilled water in the

buildings which are supplied from a central plant to include building pumps, bypass valves, bridge valves, etc. The BAS will monitor the campus loop differential pressure at each building and communicate those readings to the central plant control system. In buildings with their own chillers, the BAS will only control the secondary loops including secondary pumps, secondary bypass valves, etc.

2. Central Chilled Water Plant Controls System

The central chilled water plants are controlled through a Trane chilled water control system. The Trane controls system integrates seamlessly with the chillers on campus.

6.2 COMMISSIONING REQUIREMENTS

6.2.1 Commissioning Inspection of HVAC Systems

1. Scope of Work: The Mechanical equipment and systems defined in the project documents will be commissioned.
2. Work Included: As a minimum, the following commissioning tasks will require the cooperation, labor, materials and assistance from the Contractor and subcontractors:
 - a. Mechanical equipment installation verification
 - b. Mechanical system and equipment startup testing, adjusting and calibration
 - c. Mechanical systems functional performance testing
3. Sample Forms/Reports: Provide adequately detailed sample forms, checklists and report formats for all commissioning inspections, tests and reports which require the cooperation and assistance of the Contractor and subcontractors for completion.
4. Test Procedures:
 - a. Provide adequately detailed test procedures for all commissioning pre-functional and functional performance tests and inspections, which require the cooperation and assistance of the Contractor and subcontractors for completion.
 - b. The same procedure and equipment used in the balance and testing procedure for exhaust and make-up air for the entire building and each device in the system shall be used on balancing and functional testing for commissioning.
5. Testing and Re-Testing: Require that the Contractor and subcontractors provide all required assistance, labor, materials and supplies for specified commissioning tests. Specify that tests failing due to improper Contractor

work or preparation shall be rescheduled, and all costs of re-testing will be borne by the Contractor.

6. Project Closeout: Specify that the Contractor is responsible for the satisfactory completion of all commissioning items of this section, and of DCSM section 1.8 general commissioning requirements, prior to approval of project closeout.
7. Demonstration:
 - a. Provide project walk-through, instruction and start-up by Contractor and factory technical representative, where appropriate. Consider videotaping instructions for future reference.
 - b. In individual buildings, only closed loop systems, such as secondary heating water, shall have chemical treatment. Chemical treatment for fluids from central systems will be provided at the heating or chiller plant.

6.2.2 Commissioning of Elevators

Prior to Virginia Tech's acceptance of the installation, an inspection must be performed and acceptance tests must be witnessed by an independent elevator inspector to verify conformance of elevators and chairlifts with code requirements. The Virginia Tech shall employ the services of the independent elevator inspector. Any deficiencies shall be corrected by the Contractor at no cost to Virginia Tech. Virginia Tech requires three weeks notification prior to testing to schedule the inspector. Any re-inspection deemed necessary due to non-compliance issues will be billed to the contractor.

6.2.3 Commissioning of Laboratory Systems

1. Laboratory Ventilation: Maximum ventilation rates are to be established during the design and commissioning processes and be the greater of that required for cooling/heating loads or make-up air to maintain desired lab offsets.
2. Chemical Fume Hoods:
 - a. Face velocity shall be verified for all hoods installed during commissioning and a sticker shall be placed on the front of the hood frame before the hoods can be used by lab occupants.
 - b. All commissioning chemical fume hood testing reports shall be provided to EHS.
 - c. A label of certification must be placed on each hood by the commissioning agency before occupation of all new labs or before use of all newly installed hoods.

3. Other Laboratory Exhaust Devices: Local exhaust ventilation systems incorporating snorkels, flanged openings, and similar intake openings must be tested for exhaust capacity and the results documented during commissioning.

6.2.4 Pre-Commissioning Requirements

1. For environmental initiative documentation, drawings for electrical work shall document and identify commissioning as being mandatory for the evaluation of the project with respect to the certification being sought.
2. For energy metering, the Contractor shall coordinate with the Commissioning Authority and shall be responsible for proper installation of the meter and for enabling energy consumption calculations during construction before the service is turned on, unless instructed otherwise.
3. External Commissioning Authorities will not be allowed remote access to the BAS system.

6.3 BUILDING AUTOMATION SYSTEM

6.3.1 General Notes

1. The A/E shall coordinate specific project requirements with the VT PM and with VT Instrumentation, Controls, and Metering (ICM).
2. The BAS shall be furnished and installed by Siemens and connect to the current Siemens BAS front-end. The new BAS shall utilize electronic sensing, microprocessor-based direct digital control, and electronic actuation of dampers, valves, and devices to perform control sequences and functions specified.
 - a. All new capital projects shall utilize Desigo as the BAS front-end.
 - b. Renovation projects consisting of less than 50% of the building shall be tied into the existing network residing on Insight. Renovation projects consisting of more than 50% of the building shall be tied into Desigo and include the migration of exiting, to remain, BAS infrastructure into Desigo as well.
3. All materials shall be new, the best of their respective kinds, without imperfections or blemishes, and shall not be damaged in any way, and shall consist of the manufacturer's latest proven technology that is compatible with the existing building controls infrastructure at the time of equipment submittal. Used equipment shall not be used in any way for the permanent installation except where drawings or specs specifically allow existing materials to remain in place.

4. The installation of all equipment shall be in strict accordance with manufacturer's instructions and installation manual. All equipment shall be rated for the intended use.
5. The University reserves the right to make changes to the BAS during the warranty period. Such changes do not constitute a waiver of warranty. The installer shall warrant parts and installation work regardless of any such changes made by the University, unless the installer provides clear and indisputable evidence that a specific problem is the result of such changes to the BAS. Any disagreement between the University and the installer on such matters shall be subject to resolution through the contract 'disputes' clause.

6.3.2 VT Point Naming Standard

1. All point names for the BAS shall follow the VT BAS point naming convention which follows the CSAL point naming convention.
2. All fully qualified point names, where applicable, shall include the respective building number, equipment/system identification number, and the appropriate point abbreviation, each separated by a period. For example, "B0101.AH01.SAT" would represent a supply air temperature associated with air handler one in building 101.
3. Terminal equipment controllers shall be named by the associated room number that they serve. For example, "B0101.RM201.VAV", would represent building 101, room 201, served by a variable air volume terminal.
 - a. Rooms that are served by multiple terminal equipment, will have the terminal equipment name RMXXX.VAV1, RMXXX.VAV2, etc.
 - b. Terminal equipment that serves multiple rooms shall be named by the room number that the T-stat is located in. Other rooms that are served by the terminal equipment shall listed in the point descriptor.
4. Field panel naming convention: B0101 CAB 01
5. ALN naming convention: Sandy Hall – B0101

6.3.3 Graphics Standards

All BAS projects/renovations shall include new or updated graphics. These graphics will be created in accordance with the following:

1. A main menu for the building with graphic links to all associated system graphics.
2. One graphic per system (air handling system, exhaust system, hot water system, chilled water system, domestic hot water system, lighting system,

etc.) shall be included. Each graphic will specify the system's location and what the system serves.

3. Individual terminal equipment will be associated with the correct standard application graphic.
4. Any lab or room with HVAC equipment that is more complex than a standard application graphic can support (e.g., multiple supply terminals, exhaust terminals, and fume hoods in a single lab) will have its own individual graphic with the correct equipment and points shown.
5. Detailed floor plan graphics shall be created. These will indicate all terminal equipment (VAVs, FCUs, UHs, HPs, etc.) with associated T-stats. All HVAC equipment and field panel locations will be shown as well. All room temperatures shall be placed on the floor plan beside correct T-Stat, where they can be dragged and dropped to pull up the individual room graphic. The floor plan will also specify which AHU and exhaust system serves which space.
6. All graphics shall be sized to fit the monitors in the ICM Department.
7. Locations of field panels, terminal equipment, transformers, airflow stations, 2/3-down duct sensors, differential pressure sensors, and major equipment (chillers, AHUs, HWS, etc.) shall be shown.
8. All points on central system graphics shall have the point state color as the info block background (i.e., all points should be in blue blocks with border around them). For floor plans, all room temperature points shall be text only, with the points state color in the text. T-stat icons on floor plans shall be red; humidity icons shall be blue; and CO₂ icons shall be yellow.

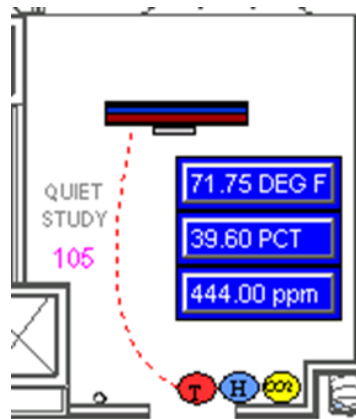

10. All system mode points (.OCC) shall be in the top right-hand corner of graphics. All graphics (with the exception of standard template graphics)

should show outside air and humidity (references from virtual OA point in equipment's control panel) in the top right corner in grey box as shown in graphic below.

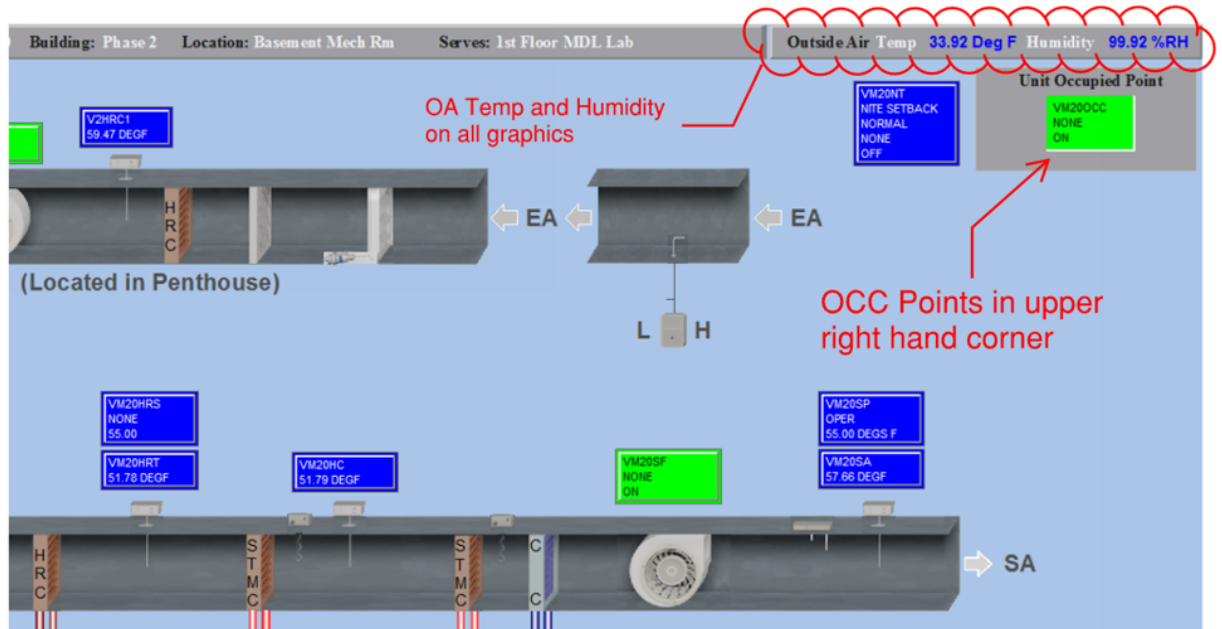

11. Points with the ability to be commanded (digital outputs, analog outputs, virtual setpoints, etc.) shall show Display Name, Priority, Current Value, and Units.
12. Monitoring points (digital inputs, analog inputs, etc.) shall show Display Name, Current Value, and Units Used.
13. Add application notes and startup guide links in the top right-hand corner of application template graphics.

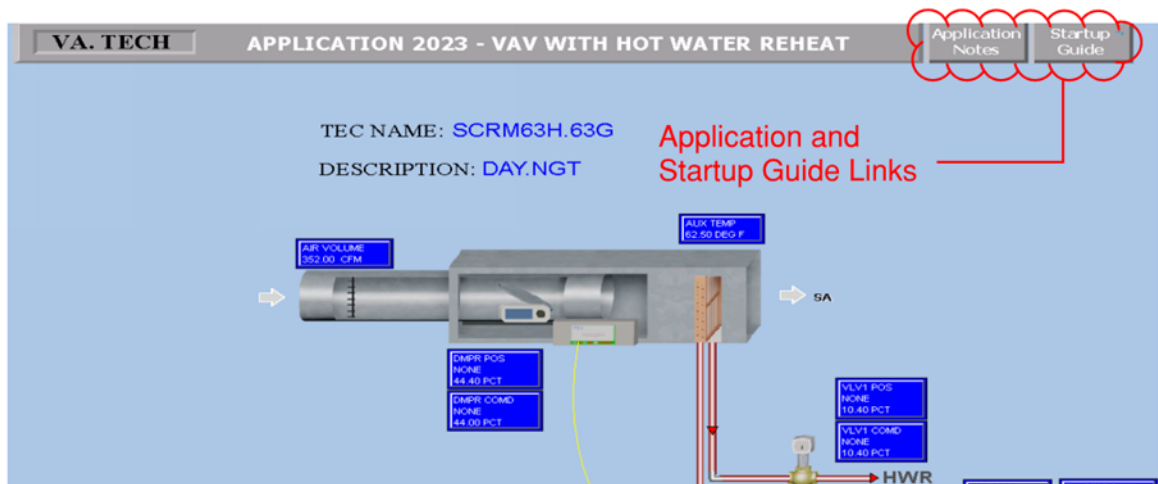

14. Provide an alarm-associated link around all AHU and major systems on the main page to show there is an alarm within that system.
 - a. Supply fan alarms should show up in orange when in alarm (Alarm Priority – PRI2).
 - b. If a set point dial is possible for that application, show it on the graphic with the day cooling and day heating points as well.
 - c. Graphic trees shall show the building name, main menu, and be expandable to see all sub-graphics.

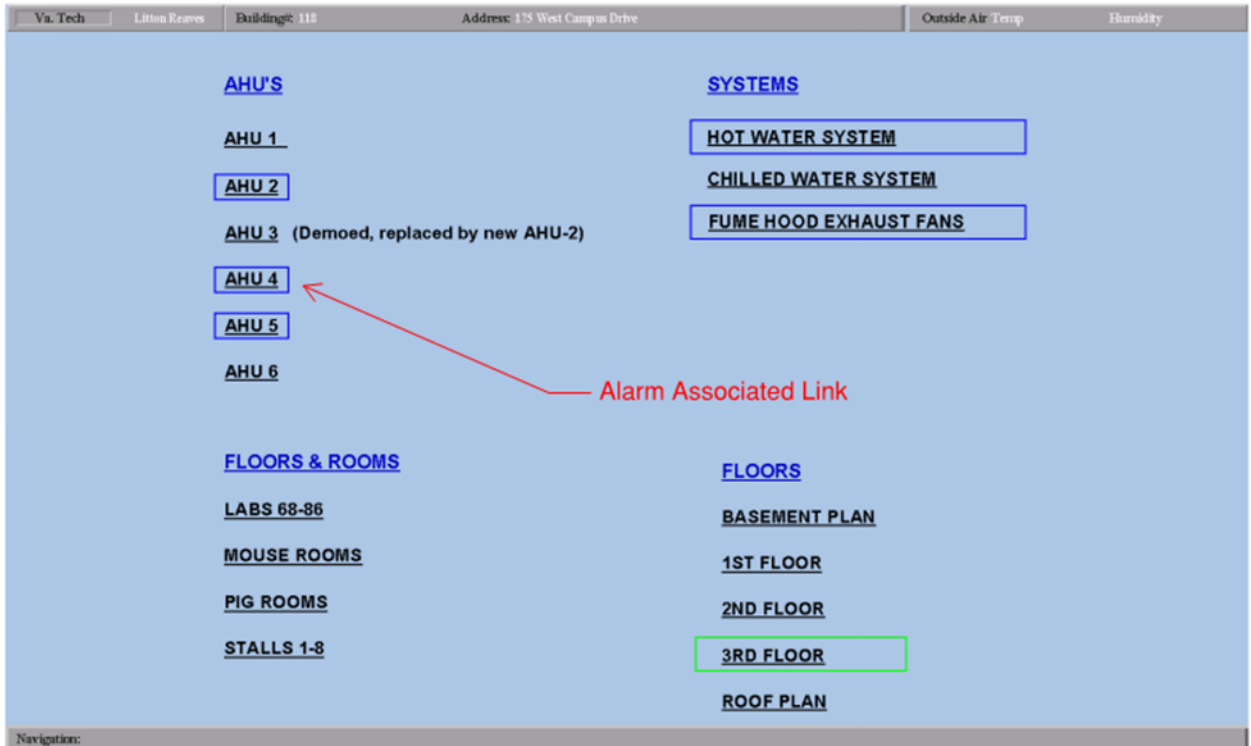

6.3.4 BAS Record Documents

1. BAS record documents shall clearly convey the physical design of the system, network layouts, as well as materials and devices used therein.
2. Each unique type of equipment shall have an equipment schematic showing hardware layout, a module or panel detail showing layout and connection, a bill of materials and a concise written sequence describing each mode of operation.
3. A network diagram shall be provided for each project, indicating the physical layout, including the routing of network wire, as well as the location of each node and the equipment it serves. This diagram should include all BAS

modules, as well as any network devices such as gateways, routers and third-party devices.

4. A power riser, power layout, including electrical panel/circuit number.
5. Record documents shall include equipment schedules detailing the specification and application of control valves, control dampers and any other equipment provided by the BAS contractor.
6. All record documents are subject to the approval of the project management and/or engineer of record.
7. Upon completion of the project, an electronic copy of the as-builts, in pdf format, shall be provided to the ICM department and stored on the BAS server in the as-builts folder (G:/ drive).
8. The controls installer shall provide the University with all product line technical manuals and technical bulletins, including new and upgraded products, throughout the warranty period of the project.

6.3.5 Third-Party Integration

1. Siemens shall be responsible for directly connecting and controlling all HVAC equipment and associated systems with the building automation system. Equipment controls provided by the equipment manufacturer (i.e., “packaged control”) are not acceptable. Any exception shall require a design waiver per DCSM section 1.3.5.
2. All third-party integration, if approved, shall be accomplished via BACNet with native BACNet controls. Integration utilizing alternative protocols (non-BACNet such as Modbus, Lon, etc.) must have additional pre-approval from the VT ICM Department.
3. Where a third-party interface is approved for the equipment control and sequencing, the interface shall be native BACNet as provided by the manufacturer.
4. Where a third-party interface is approved, the equipment provider shall provide a factory trained startup technician certified to configure the BACNet device.
5. All BACNet instance numbers, network IDs, MAC addresses, and port numbers, shall be coordinated with the VT ICM Department and requested during the wavier application.

6.3.6 BAS Network Configuration

1. Please contact the ICM Department for next available BACNet addresses and instance numbers.

2. Any IP address requests associated with the BAS shall be made through the ICM Department.
3. BACNet Broadcast Management Devices (BBMDs) are assigned by the ICM department. When a new network controller is connected to the BAS network, the BAS installer shall coordinate with the ICM Department to configure any necessary BBMDs. Automatic management of the BBMDs shall be disabled.
4. All default/generic user accounts and passwords shall be changed prior to placing any controller online in the production environment. All device username and password information shall be turned over to the ICM Department.

6.3.7 Lab Controls

1. The basis of design for all lab supply air valves, lab general exhaust air valves, and fume hood exhaust air valves shall be Siemens lab controls. Third-party lab controls are not acceptable.
2. The basis of design for fume hood controllers shall be Siemens fume hood controllers with sash sensor and operator display panels. Third-party fume hood monitors are not acceptable.

6.3.8 Trending and Reporting

6.3.8.1 Typical Trending

Typical Point Trending at the Field Panel Level

1. Interval trending, unless otherwise specified, shall be in 15-minute intervals with 400 samples collected in the field panel.
2. Change of value (COV) trending shall be for binary (on/off) points and shall be for a minimum of 48 hours of data.

Trending on all new installation/renovation projects shall include trending at the field panel level of all necessary physical points and virtual set points as follows:

1. Air Handling Unit (Typical)
 - a. AIs – SAT, RAT, MAT, OAT, RMT, RAH, SAH, RMH, DDP,
 - b. AOs – CCV, HCV, RHV, MAD
 - c. AVs – SAS, RAS, RMS, RHS, SHS, RHS, DPS
 - d. BOs – SAF, RAF, EAF
 - e. BIs – SAF, RAF, EAF, FIL, FRZ, HSP
 - f. BVs – SCH
 - g. MS – OCC

2. Hot Water Systems
 - a. AIs – HWS, HWR, DP
 - b. AOs – HXV, BPV, P1S, P2S
 - c. AVs – DPS, HWSTPT
 - d. BOs – P1, P2
 - e. BIs – P1, P2
 - f. BVs – OCC
3. Building Steam: AIs – LPP, LPF, LPT
4. Building Chilled Water: AIs – C
5. Exhaust Systems
 - a. AIs – DP
 - b. AOs – BPD
 - c. AVs – STPTs
 - d. BOs – EAF
 - e. BIs – EAF
 - f. BVs – OCC
6. Other mechanical systems: All of the mechanical systems not listed (process cooling, domestic hot water, etc.) shall have the physical points trended and relevant set points trended.
7. Floor Level Devices
 - a. AIs – Room Temp
 - b. AOs – CTL STPT
 - c. BIs – Occupancy Sensors (if installed)

6.3.8.2 Reporting

All critical equipment and spaces shall have scheduled reports created in coordination with VT Facilities' BAS management and/or as listed in the job specification. Typical critical spaces include but are not limited to the following:

1. Vivariums (Animal Holding)
2. Critical labs (BSL)
3. Food Storage (Freezers and Coolers)

All trend collections to the BAS front end shall be created in coordination with VT Facilities' BAS management and/or as listed in the job specification.

6.3.9 Temperature and Humidity Sensors

1. Space Temp and Humidity Sensors
 - a. All space and humidity sensors shall be located at or near the door, the light switch, and at 60 inches to center.

- b. Non-display sensors shall be used in public spaces (hallways, bathrooms, etc.).
 - c. Include thermostat guards for obvious hazardous locations (gyms, mechanical rooms, etc.).
2. Critical Space Humidity Sensor: Basis of design for all critical space humidity sensors shall be Vaisala HMW92.

6.3.10 Hydronic Differential Pressure Transmitter

1. Hydronic differential pressure transmitters shall be the remote transducer type (rather than integrated transducers). Basis of design is Setra 230 5-port manifold.
2. Each transducer shall include a 5-port manifold necessary to isolate, bleed, and test the individual sensor (see schematic).

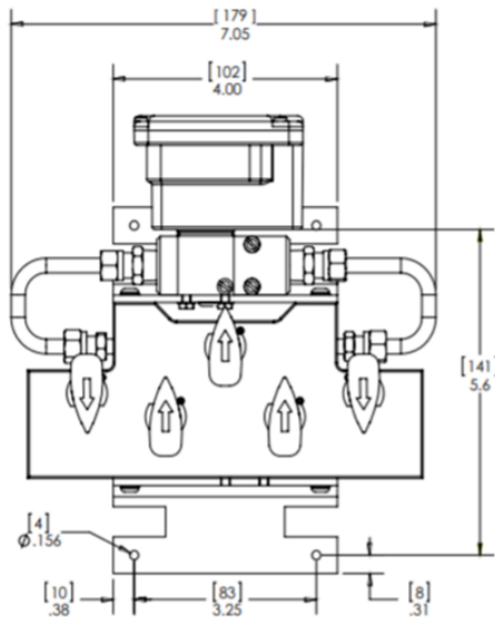

6.3.11 Low Voltage and Communications Wiring

1. The wire basis of design is Anixter wire. Equivalent products may be used, provided their specifications meet or exceed the basis of design.
2. The term “control wiring” is defined to include the providing of wire, conduit, and miscellaneous materials as required for mounting and connecting.
3. All exposed control wiring and control wiring in the mechanical, electrical, telephone, and similar rooms shall be installed in conduit. All other wiring shall be installed neatly and inconspicuously above ceilings, anchored to the

permanent building structure, with supports no more than 6 feet apart. Any exposed wiring shall be plenum rated cable.

4. All ALN/BLN (Area Level Networks, Building Level Networks) shall be in conduit.
5. Critical safety interlocks, such as low temperature detection, high limit protectors, end switches, etc., shall be directly connected through wire, so as not to depend on any digital control system “sequence of operation” to perform their safety function. Contacts shall be provided so the safety can be monitored by the BAS. Low temperature detection and static pressure switch contacts shall be mechanically latching and only reset manually.
6. All Ethernet wiring shall be CAT6.

6.3.12 Control Panel Layout

1. Conventions:
 - a. All line voltage wiring and connections must be protected behind covers and/or in raceways. Exposed line voltage circuitry is prohibited.
 - b. Control wiring shall be neatly routed and terminated without excessive cable length. Wherever possible, control wiring should be concealed by wire duct.
2. Line voltage power:
 - a. All control panels shall be served by dedicated emergency power circuits from the same source and service level provided to the equipment controlled. Low voltage control power for fume hoods must also be served by dedicated emergency power circuits. The control panel shall be labeled with the electrical panel name and circuit source.
 - b. The BAS installer shall furnish and install any power supply surge protection, filters, etc., as necessary for proper operation and protection of all controllers. All control equipment must be tolerant of voltage variations 10% above or below scheduled nominal with no impact on hardware, software, communications, or data storage.
 - c. Unless extremely critical, UPS are not allowed. In the event of highly critical equipment/spaces (e.g., BSL3), UPS must be hybrid in nature. Critical UPS basis of design will be Sola S4K2UC or equivalent. A central, online UPS may be used in place of an individual UPS for BAS equipment.
3. Labeling:
 - a. Panel layouts, network riser diagrams, and power riser diagrams shall be provided in each panel upon completion of the project.
 - b. All wires and devices (filed panels, transformers, relays, etc.) in the control panel shall be labeled.

- c. The cabinet shall be clearly labeled on the outside.

6.3.13 Actuators and Valves

1. Damper Actuators
 - a. The basis of design for automatic control damper actuators serving central systems shall be Belimo. This includes central air handling units and central exhausts systems.
 - b. The basis of design for automatic control damper actuators on terminal equipment shall be Siemens. These systems include heat pumps, VAV boxes, fan coil units, unit ventilators, cabinet unit heaters, and other terminal systems serving rooms and common areas.
 - c. The basis of design for control of all automatic damper actuators shall be Siemens DDC controllers.
2. Control Valves
 - a. The basis of design for control valves shall be Siemens. Control valves shall be provided by Siemens, but installed by the mechanical contractor.
 - b. Terminal units shall use Powermite MZ globe valves.
 - c. Central systems such as air handling units, chilled water systems, and hot water systems shall use Flowrite globe valves.
 - d. Automatic isolation valves shall be 2-position ball or butterfly valves where appropriate.

6.3.14 Access to the BAS

Access to the BAS shall be by approval only. The request shall be submitted to the ICM shop and ultimately approved by the Director of Facilities Engineering and Assessment.

VT does not allow external users to access the BAS systems remotely. This includes Commissioning Authorities, Engineers, or other non-VT agencies.

6.4 NETWORK COMMUNICATIONS

6.4.1 Summary

VT Network Infrastructure and Services (NI&S) specifications are to be used for all new construction and major renovation projects.

1. Major renovation projects are defined as complete buildings, floors, or work group areas which require new telecommunication rooms and cabling to the new room(s).
2. Renovations that will require cabling to existing NI&S rooms may have materials or installation techniques that do not conform to these standards.

These types of small renovations are considered outside the scope of this section and requests for these types of cabling projects must be submitted to NI&S Customer Support Services (CSS) at (540) 231-6460 or at nis-projects-g@vt.edu.

Network Infrastructure & Services, part of Virginia Tech's Information Technology organization, is responsible for installing, operating, managing and maintaining the University's telephone, data and CATV systems. The telecommunications cabling system described in this section will be utilized by NI&S to provision these services to the University. NI&S is responsible for the ongoing management and maintenance of University telecommunications cabling systems including adding, removing and or relocating cabling as required to support the needs of the University as persons and departments relocate and/or their requirements change over time. NI&S is certified by The Siemon Company (Siemon) and Optical Cable Corporation (OCC) as required to perform this ongoing cable plant work without voiding the manufacturer's warranties provided by these companies.

The products and execution from this section are the accepted practices from NI&S and any products or execution outside this section shall require a design waiver per DCSM section 1.3.5.

Every effort has been made to use industry standard terminology throughout this section, but industry standard terminology is not used by all manufacturers and, in many cases, industry standard terminology does not exist. Contractor shall notify the VT PM and NI&S personnel to define terminology used in specifications if they believe any questions could arise.

This section is not intended to eliminate the need for a detailed review of a new project between the designers, the end users, and NI&S engineers. The best and most cost efficient method for designing a building's telecommunications infrastructure is to have the A/E team, the VT PM, and the NI&S design representative meet with the future occupants of the building and discuss in detail the telecommunications needs for the buildings. These meetings help avoid unnecessary infrastructure being installed and necessary infrastructure being omitted; both of which drive up project costs. These meetings should occur after the schematic design drawings are released but before the end of preliminary design.

Drawings, Contract Forms, and Conditions of the contract, including Construction Manager/General Contractor (CM/GC) agreement including Exhibits and other VT DCSM sections, apply to this section.

All service activation requests, or modification of existing services, must be submitted by the requesting department to NI&S Customer Support Services (CSS) at (540) 231-6460 or at cssnis@vt.edu.

The Contractor shall review related project documents and report any and all concerns prior to installation.

In the event of a conflict or discrepancy between this section and other project related documents, the Contractor shall submit a written request for clarification to NI&S for resolution.

6.4.2 Bidding Requirements for Communications Projects

1. Refer to DCSM section 6.4.4 for the minimum qualifications for the Communications Contractor.
 - a. Proof of the Communication Contractor's current enrollment in the Siemon Company's Certified Installation Program is required.
 - b. Proof of the Communication Contractor's current enrollment in the Optical Cable Corporation Certified Multimedia Design and Integration Specialist Program is required.
2. Contractors will provide pricing options for a complete Category 6 or a complete Category 6A structured cabling solution based on the requirements found in these standards. The VT PM and NI&S will coordinate with the building occupant's representative to determine the department's bandwidth requirements and will specify the applicable solution for each project.
 - a. A complete structured cabling system, as described within these specifications, includes the following:
 - i. Equipment Rooms (ERs)/Telecommunication Rooms (TRs)
 - ii. Copper and fiber backbone cabling and connectivity
 - iii. Copper horizontal cabling (station cabling) and connectivity
 - iv. Grounding and bonding of telecommunications pathways and equipment
 - v. Labeling and Testing
 - vi. Firestopping
 - b. A complete structured cabling system, as described within these specifications, does not include the following:
 - i. Outside Plant pathways and backbone cabling
 - ii. Network Electronics
 - iii. Uninterrupted power supplies/power strips

3. Refer to DCSM section 6.4.4.8.6 for firestop requirements and refer to the Architectural drawings for ratings of existing and new walls, floors, and other surfaces in the project area.

The base bid for a project containing communications cabling is required to include all firestop installation and materials for all communication cabling in the project area.

6.4.3 Operation and Maintenance of Communications Systems

6.4.3.1 Contract Administration

The Contractor shall carefully study and compare the contract documents and shall at once report to the VT PM and NI&S any error, inconsistency or omission identified. If the Contractor performs any construction activity knowing it involves a recognized error, inconsistency or omission in the contract documents without such notice, the Contractor shall assume appropriate responsibility for such performance and shall bear an appropriate amount of the attributable cost for correction.

The Contractor shall advise the VT PM and NI&S as early as possible of any product delays and minimum quantity requirements that may affect the project timeline. Should conflicts, discrepancies, deficiencies, or errors arise which require changes in the Contract Documents, immediately notify the VT PM and NI&S. Failure to do so shall be interpreted as the intention of the Contractor to supply all necessary labor and materials for the suitable completion of this work. Obtain written approval on necessary adjustments before the installation is started.

6.4.3.2 Project Management and Quality Assurance

1. The Contractor shall designate and identify a Project Manager to oversee the project work specified in this section and to attend all necessary project meetings as a representative of the Contractor. The Contractor's Project Manager shall have the authority to act for the Contractor, and all communications given to the Project Manager will be deemed to have been given to the Contractor.
2. The Contractor shall not begin construction on any project without written notice to proceed.
3. All additional costs must be approved in writing with a change order signed by the VT PM.

6.4.3.3 Job Supervision

1. Designate and identify job supervisor in advance.
2. Provide no more than one supervisor per job.
3. Provide one primary contact, one backup contact.
4. Maintain the following information on the job site:
 - a. All project related drawings (drawings to include NI&S provided H-Link/Portal identification information – see DCSM section 6.4.10)
 - b. All addenda
 - c. Submittals
 - d. All Change Orders
 - e. Any inspection reports from NI&S and/or Structured Cabling System manufacturer
 - f. Test results
 - g. Schedule and outage logs
 - h. As-built drawings set showing all changes
5. Assist NI&S and manufacturers' representatives in performing periodic inspections for evaluation and functional testing of communications subsystems or sections.
6. Assist NI&S and manufacturers' representatives in performing evaluation and functional testing of complete communications system(s).
7. Conduct an overall quality assurance program.
8. Apply and install materials, equipment, and specialties in accordance with manufacturer's written instructions. Conflicts between the manufacturer's instructions and these specifications shall be referred in writing to NI&S for resolution.
9. All products, components, devices, equipment and materials shall be new and unused, clean, free from defects, and free from damage and corrosion.
10. Installation and service shall be performed by manufacturer trained and certified personnel.

6.4.3.4 Submittals

1. The Contractor shall submit for review and approval by NI&S a complete list of all materials, components, equipment, systems, and products proposed. Any requests for substitutions must be submitted with complete product data.
2. Product submittals shall show, as a minimum, the following:
 - a. Manufacturer, color, complete model and part number

- b. Dimensions
 - c. Complete technical specifications and performance data
 - d. Any other pertinent information necessary to determine adequacy for the intended application
3. When not provided by the project A/E, the Contractor shall submit for review and approval by NI&S a complete set of shop drawings detailing the Contractor's design plans for each specification section. Shop drawings must include an overall site plan with any outside plant telecommunications pathways shown, exterior and/or interior cable pathway details (including quantity and sizes), room construction plans (including wall and rack details, equipment elevations, grounding systems, conduit pathways, etc.), copper and fiber backbone cabling plans, work area outlet details (including outlet labeling plans).
 4. Two sets each of hard copy and electronic shop drawings are required to be submitted to NI&S via the VT PM.
 5. Generate shop drawings using the VT CAD Standards in DCSM section 2.4.

6.4.3.5 Substitutions

Requests to substitute for specified items or previously approved materials or equipment shall be submitted by the Contractor to the VT PM and NI&S for review. Substitution requests shall include all required submittals and shall be complete with reasons for substitutions and savings which will accrue to the project if substitutes are approved. Substitutes will be considered only if equal or superior to those specified and do not void specified cable system manufacturer's warranties.

6.4.3.6 Statement of Warranty

The Contractor shall provide statements of warranty based on both the structured cabling and fiber optic system manufacturers' performance warranties as well as the Contractor's parts and labor warranty.

6.4.3.7 Periodic Field Observation Reports

NI&S and cabling systems manufacturers' warranty representatives will conduct site visits as required to monitor the progress and quality of the workmanship, the work environment, as well as the surrounding facility. Any item found by NI&S and/or the cabling system representatives to be deficient will be documented in a periodic field observation report.

The Contractor shall take appropriate action to immediately correct and rectify any items deemed to not meet plans and specifications by NI&S and/or the cabling systems manufacturers' warranty representative. The Contractor shall not wait for a hard copy of the periodic field observation report if the action required to rectify the situation is communicated to them.

6.4.3.8 Inspections and Tests

The Contractor has requirements for inspections and testing. The Contractor shall:

1. Furnish, without additional charge, all test equipment with up to date calibration, instruments, facilities, labor, and material needed to perform safe and convenient inspection and testing.
2. Submit to NI&S a complete project schedule and timeline including installation, inspection, and testing for each project area prior to beginning work, so that interim inspections can be conducted as work progresses. NI&S shall not be obligated to inform the Contractor of its intent to inspect job sites while work is in progress.
3. Perform pre-testing of the installed telecommunications systems to determine compliance and notify NI&S personnel when the system is ready for final inspection and testing.
4. The Contractor shall leave all work uncovered for a minimum of five business days from the date of a notification to NI&S of a request for inspection. Overhead work shall not be covered up or enclosed until inspected by NI&S personnel or other proper authorities. Should any work be covered up or enclosed before such inspection, it shall be uncovered, inspected, and after approval, restored by the Contractor to finished condition at no additional cost to the project.
5. Replace or correct, without charge, any material or any workmanship found by NI&S not to conform to the specifications, unless NI&S consents to accept such material or workmanship with appropriate adjustment in price. All work that is determined to be unsatisfactory shall be corrected immediately. The Contractor shall promptly segregate and remove rejected material from the premises. The Contractor will pay the additional cost of any test or inspection of the replaced material or corrected workmanship.
6. Submit final test results as described in this specification for review and acceptance by NI&S and the cabling systems manufacturers' warranty representatives.

6.4.3.9 Continuity of Services and Scheduling

The building may be in use during construction operations. Insofar as possible, the Contractor shall employ such methods or means as will not cause interruption of, or interference with, the owner's scheduled use of the building and will maintain existing systems in operation within all rooms outside of the scope of the project at all times.

1. For areas under renovation, coordinate all installation activities with the VT PM and other trades for renovations of architectural, mechanical, and/or electrical facilities. Insofar as possible, the Contractor shall employ such methods or means as will not cause interruption of, or interference with, the work of any other contractor.
2. Moving or removing any facility related to providing telecommunications services must be done under the supervision of NI&S so as not to cause interruption of the project work or of University operation.
3. Disruption of critical services will require after hour or weekend working constraints.
4. Existing communication services shall be interrupted only with consent from the VT PM and NI&S. An advance warning time of seven working days shall be given. Such interruptions shall be preceded by all possible preparations which will minimize down time to expedite that particular phase of the work pursuant to good workmanship. This shall be done during regular and/or premium time as approved by the VT PM without additional expense to the project.
5. Adjust work schedule within reason (weekly), as per direction of the VT PM, and coordinate with work or other trades in order to make portions of project available as soon as possible.
6. All expenses due to untimely or improperly coordinated work shall be the responsibility of the Contractor.

6.4.3.10 Use of Cable Prior to Acceptance

The Contractor shall permit the placement and installation by NI&S of cross-connects, patch cords, and/or equipment onto cable and terminations installed under this contract, prior to substantial completion of the contract as necessary. Such placement or installation shall not evidence completion of the work or portion thereof, nor signify NI&S acceptance of the work or portion thereof.

6.4.3.11 Final Acceptance and Work Closeout

1. Contractor shall inspect the entire telecommunications system installation to assure all work is completed and all systems are completely operational before calling for final inspection, testing and acceptance of work.
2. Punch list closeout:
 - a. Notify NI&S when telecommunications work is ready for final inspection and punch list preparation.
 - b. The Contractor shall submit for review and approval by NI&S a complete set of as-built drawings including:
 - i. Cover with legends.
 - ii. Site plan with Outside Plant building entrance conduits shown.
 - iii. Riser diagrams showing conduit (include size and quantity), grounding, and all backbone cabling (multi-pair copper, multi-mode fiber, single-mode fiber and Coaxial).
 - iv. Floor Plans with all outlet locations.
 - v. ER details with Footprint, Equipment Rack Layout, conduit locations and Wall Design.
 - vi. All additional TR details with Footprint, Equipment Rack Layout, conduit locations and Wall Design.
 - vii. Horizontal pathway details including paths for all cable tray and conduits. Details must include quantity and sizes of all horizontal pathways.
 - viii. Details sheet with Faceplates, Wireless Plates (Surface Box), Wireless Boxes, Camera Box, Floor Box, Box Assembly, etc.
 - c. Generate as-built drawings using the VT CAD Standards in DCSM section 2.4.
 - d. Two sets each of hard copy and electronic as-built drawings are required.
3. After the successful installation inspections and functional testing by NI&S and the Contractor, NI&S will determine if there are any open issues or discrepancies and notify the Contractor via the VT PM. Upon completion or determined failure, NI&S will issue written notification to the Contractor as to the status of the installation acceptance.

6.4.4 Common Work Results for Communications

6.4.4.1 Related Documents

1. Design, manufacture, test, and install telecommunications cabling networks per manufacturer's requirements and in accordance with NFPA-70 (latest adopted edition of the National Electrical Code®), IEEE C2 (latest adopted edition of the NESC), state codes, local codes, requirements of authorities having jurisdiction, and particularly the following standards:
 - a. ANSI/BICSI N1-2019, Installation Practices for Telecommunications and ICT Cabling and Related Cabling Infrastructure
 - b. ANSI/TIA/EIA Standards:
 - i. ANSI/TIA-568-C.0-2 – Generic Telecommunications Cabling for Customer Premises – Addendum 2, General Updates
 - ii. ANSI/TIA-568-C.1 – Commercial Building Telecommunications Cabling Standard, Part 1: General Requirements
 - iii. ANSI/TIA-568-C.2 – Commercial Building Telecommunications Cabling Standard, Part 2: Balanced Twisted Pair Cabling Components
 - iv. ANSI/TIA-568-C.3-1 – Optical Fiber Cabling Components Standard
 - v. ANSI/TIA-569-C – Commercial Building Standard for Telecommunications Pathways and Spaces
 - vi. ANSI-J-STD-607(B) – Commercial Building Grounding and Bonding Requirements for Telecommunications
 - vii. TIA-526-7-OFSTP-7 – Measurement of Optical Power Loss of Installed Single-Mode Fiber Cable Plant
 - viii. TIA-526-14-B-OFSTP-14-B – Optical Power Loss Measurements of Installed Multimode Fiber Cable Plant
 - ix. ANSI/TIA-758(B) – Customer-Owned Outside Plant Telecommunications Cabling Standard
 - c. Install cabling in accordance with the most recent edition of BICSI® publications:
 - i. BICSI – Telecommunications Distribution Methods Manual
 - ii. BICSI – Installation Transport Systems Information Manual
 - iii. BICSI – Outside Plant Design Reference Manual
 - iv. BICSI – Wireless Design Reference Manual
2. Federal, state, and local codes, rules, regulations, and ordinances governing the work, are as fully part of the specifications as if herein

repeated or hereto attached. If the contractor should note items in the drawings or the specifications, construction of which would be code violations, promptly call them to the attention of the VT PM in writing. Where the requirements of the Virginia Tech specifications are more stringent than applicable codes, rules, regulations, and ordinances, the specifications shall apply.

3. Some differences exist between the standards listed above and the Virginia Tech specifications detailed in this document. These differences may include room construction specifications, work area outlet quantities and configurations, etc. Where differences occur, the specifications detailed herein shall apply unless not specifically allowed by code.
4. Maintain separate sets of redlined record drawings for the communications work, which show the exact placement, and identification of as-built system components. These are subject to weekly review by the VT PM.
5. Provide communication room record drawings which indicate exact placement for all components (conduit, wireway, cable tray, backboards, equipment cabinets, equipment racks, cross-connect equipment, etc.).
6. Provide communication wiring and cabling record drawings and schedules which indicate exact placement, routing, and connection details for all components (twisted-pair cables, splices, cable cross-connect termination locations, enclosures, telecommunications outlets, and cross-connect jumpers, patch cords, etc.).
7. Cabling Administration Drawings: Show building floor plans with all telecommunications outlets identified including NI&S-provided outlet/cable designations for each location. Identify labeling convention and show labels for TRs and ERs, riser pathways and backbone cables, entrance pathways and termination panels/cabinets.

6.4.4.2 Scope of Work

1. Work includes, but is not limited to, the following:
 - a. Placement of Telecommunications Room (TR) and Equipment Room (ER) hardware including equipment racks, cable routing hardware, copper and fiber termination equipment, and grounding and bonding.
 - b. Placement of and additions to interior telecommunications pathways including conduit, cable tray, pull boxes, and metallic surface-mount raceway systems.

- c. Placement of and additions to exterior telecommunications pathways including building entrance conduit systems.
 - d. Installation and termination of backbone cabling including multi-pair copper cabling, coaxial cabling, and single-mode and multimode fiber optic cabling.
 - e. Installation and termination of horizontal cabling including copper unshielded twisted pair (UTP) cabling, and coaxial cabling.
 - f. Testing, identification, and administration for the above telecommunications systems.
 - g. Removal of existing horizontal cabling, terminations, and outlets in coordination with electrical contractor for removal of associated conduit in areas where renovations require demolition of existing telecommunications outlets.
2. All work shall be conducted in coordination with NI&S and other building trades.
 3. The work covered by this section consists of furnishing all materials, accessories, connectors, supports, equipment, tools, setup, preparation, labor, supervision, incidentals, transportation, storage, and related items and appurtenances, and performing all operations necessary to complete the telecommunications work as indicated in the project drawings and specified herein. It is the intent and purpose of this specification to have, upon completion of the project, a “turn-key” telecommunications system. This system shall be designed, built, coordinated and integrated with the existing telecommunications system and complete and operable in all respects to which, upon receiving activation orders from the building’s occupants, NI&S can deploy network electronics to successfully integrate the cabling system into the campus network.
 4. Completely install, connect, and test all systems, equipment, devices, etc., shown or noted or required to leave ready for satisfactory operation. Provide any minor items omitted from the design, but obviously necessary to accomplish the above intent.
 5. All telecommunications designs for VT buildings on and off campus must be approved by NI&S for compliance to the Virginia Tech standards. Any design outside of these standards must be approved and include a written agreement for the design from NI&S.
 6. Minimum composition requirements and/or installation methods for the following materials and work are included in this section:
 - a. Cables
 - b. Factory Assembled Products

- c. Compatibility of Related Equipment
- d. Special Tools and Kits
- e. Firestop and Penetration Seals
- f. Anchoring and Supports
- g. Grounding and Bonding
- h. Cutting and Patching
- i. Concealment
- j. Equipment Modification

6.4.4.3 Definitions

Every effort has been made to use industry standard terminology throughout this specification, but industry standard terminology is not used by all manufacturers and, in many cases, industry standard terminology does not exist. Contractor shall notify the VT PM and NI&S Personnel to define terminology used in specifications if they believe any questions could arise.

1. Approved/Approval – Written permission to use a material or system
2. Contractor – Telecommunications Contractor performing work under DCSM section 6.4.
3. Engineer – Telecommunications engineer for DCSM section 6.4.
4. Equal/Equivalent – Equally acceptable as determined by NI&S
5. Final Acceptance NI&S acceptance of the project from Contractor
6. Furnish – Supply and deliver to installation location
7. Inspection – Visual observation or cable certification testing
8. Install – Mount and connect equipment and associated materials as required to make ready for use
9. Jack – Modular connector for station cabling medium (UTP copper, fiber, coax) at work-area outlet.
10. Outlet – Box and faceplate to accommodate up to six modular jacks at the work-area.
11. Pull-Box – Box to be used for pull-through of cabling in a conduit run. Not to be used as a junction box.
12. Provide – Furnish and install complete with all details and ready for use
13. Relocate – Disassemble, disconnect, and transport equipment to new locations, then clean, test, and install ready for use
14. Replace – Remove and provide new item
15. Telecommunications – All work specified in DCSM section 6.4.

6.4.4.4 Contractor Qualifications

1. The Contractor shall at a minimum possess the following qualifications:
 - a. Be in business a minimum of five years.
 - b. Contractor shall demonstrate satisfaction of sound financial condition and can be adequately bonded and insured if the project deems necessary.
 - c. Possess those licenses/permits required to perform telecommunications installations in the specified jurisdiction.
 - d. Personnel knowledgeable in local, state, province and national codes and regulations. All work shall comply with the latest revision of the codes or regulations. When conflict exists between local or national codes or regulations, the most stringent codes or regulations shall be followed.
 - e. Must possess current liability insurance certificates.
 - f. Contractor must employ at least one currently registered BICSI RCDD having documented experienced with structured cabling design equivalent to the scope of work found in these specifications.
 - g. Provide at least three references from customers where the type and size of installation provided in this specification was successfully completed within the past five years.
 - h. Must have personnel proficient in the use of CAD and possess and operate CAD software using .DWG or .DXF format.
2. Required Contractor Training:
 - a. The Contractor shall be fully conversant and capable in the cabling of low voltage applications such as, but not limited to data, voice and imaging network systems. The Contractor shall at a minimum possess the following qualifications:
 - i. Personnel trained and certified in the design, installation, and certification of the Siemon Cabling System for horizontal and backbone UTP copper cable distribution and the Optical Cable Corporation System for backbone fiber riser distribution.
 - ii. Personnel trained and certified in the design, installation, and certification of Optical Cable Corporation (OCC) fiber optic cabling and components via OCC's Multi-media Design and Integration Specialist (MDIS) program.
 - iii. Personnel trained in the installation of pathways and support for housing horizontal and backbone cabling.

- b. The Contractor shall show proof of current enrollment in the Siemon Cabling System's cabling partners program via an up-to-date certificate given after attending the CI training course or an on-line re-certification class given every two years.
 - c. The Contractor shall show proof of current enrollment in OCC's MDIS program.
3. Contractor Responsibility:
- a. Contractor shall be obligated to exercise the highest standards of care in performing its obligations as defined in this request for proposal.
 - b. Contractor acknowledges that NI&S will rely on contractor's expertise, ability and knowledge of the system being proposed and shall be obligated to exercise the highest standards of care in performing its obligation as defined in these specifications.
4. Manufacturer Quality and Product Substitutions
- a. All telecommunications connecting hardware and cable must be made by an ISO 9001 Certified Manufacturer.
 - b. All products must meet the technical requirements listed herein. Any products not meeting these requirements will not be considered.

6.4.4.5 Drawings And Specifications

- 1. It is the intention of these specifications and related project drawings to call for finished work, tested and ready for operation in complete accordance with all applicable codes, regulations, standards, and ordinances.
- 2. These specifications and the project drawings are complimentary, and what is called for in either of these shall be binding as though called for by both. Should any conflict arise between the drawings and specifications, such conflict shall be brought to the attention of the VT PM for resolution. If the Contractor fails to contact the VT PM in writing of any conflict between the specifications and the project drawings, the Contractor shall be subject to re-work the area of conflict at the Contractor's cost.
- 3. Omissions from the specifications and/or project drawings or the incorrect description of details of work which are evidently necessary to carry out the intent of the specifications and project drawings, or which are customarily performed, shall not relieve the Contractor from performing such omitted or incorrectly described detail of the work.

4. The telecommunications and technology project drawings are diagrammatic and indicate general design, layout, and arrangement of equipment and various systems. Being diagrammatic, the drawings may not necessarily show all details such as pull-boxes, conduit runs or sizes, etc., necessary for a complete and operable system. Unless detailed dimensioned drawings are included, exact locations are subject to approval of the VT PM.
5. The amount of varying types of telecommunication symbols should be kept to a minimum. A number should be placed next to each symbol to indicate the quantity of cables to be located at each data outlet box.
6. All telecommunications cables intended to be connected to the University's network should be shown on the telecommunications drawings regardless if they are shown on A/V, Security, etc., so that the cable plant infrastructure is clearly defined.
7. Do not scale project drawings for dimensions. Take all dimensions and measurements from the site and actual equipment to be furnished. All dimensions, measurements, and the location and existence of underground equipment or facilities must be verified in the field since actual locations, distance, and elevations will be governed by actual field conditions. Contractor shall be responsible for all measurements taken from the field.

6.4.4.6 Examination of Project Site

1. Prior to any project work, examine the project site carefully, including all project drawings showing existing systems and equipment. The Contractor shall make themselves fully informed of and shall identify all utility, state, and local requirements that will affect the telecommunications work at the project site.
2. It shall be the Contractor's responsibility to determine if the installation of the proposed systems will affect the operation or code compliance of existing systems. Only while under NI&S supervision, relocate, modify, or otherwise revise existing telecommunications systems as required to maintain operational integrity and code compliance.
3. The Contractor shall become familiar with the local conditions under which the work is to be performed and correlate the on-site observations with the requirements of the specifications and project drawings. No allowance will be made for claims of concealed conditions which the Contractor, in exercise or reasonable diligence in examination of the site, observed or should have observed.

4. Before ordering any materials or doing any project work, verify all measurements and be responsible for correctness of same. No extra charge or compensation will be allowed for duplicate work or material required because of unverified differences between actual dimensions and the measurements indicated on the project drawings. Any discrepancies found shall be submitted in writing to the VT PM for consideration before proceeding with the project work.

6.4.4.7 Workmanship, Warranty, and Support

1. Materials and workmanship shall meet or exceed industry standards and be fully guaranteed for one full year from final acceptance for each project. Cable integrity and associated terminations shall be thoroughly inspected, fully tested and guaranteed as free from defects, transpositions, opens/shorts, tight kinks, damaged jacket insulation, etc.
2. Furnish a written warranty to VT for a minimum of:
 - a. One-year materials warranty on parts and labor to repair/replace defective telecommunications materials specified herein. This warranty only applies to materials provided by Contractor and does not apply to materials provided by NI&S.
 - b. One-year installation workmanship warranty on parts and labor to resolve problems related to telecommunications system installation workmanship.
 - c. A minimum twenty year manufacturer's performance warranty on parts and labor to repair/replace defective telecommunications cabling materials. The installer/contractor shall be certified by the following cabling systems manufacturers to provide the materials warranty.
 - i. Siemon Cabling System (Siemon System 6 or 500 MHz Z-Max 6A Cabling System Warranty – dependent on Category specified by project)
 - ii. OCC Fiber Optic Systems
3. The appropriate cabling system manufacturer shall be responsible for and make good, without expense to VT, any and all defects in any part of either the Siemon or OCC related systems arising during this 20 year warranty period that are due to imperfect materials, appliances, improper installation, or poor workmanship.
 - a. During the 20 year warranty period, provide all labor required to repair or replace defects in the telecommunications system, at no cost to VT.

- b. During the 20 year warranty period, provide new materials to repair or replace defects in the telecommunications system, at no cost to VT.

6.4.4.8 Materials

6.4.4.8.1 Equipment and Materials Minimum Requirements

1. All materials and equipment shall be new, free from defects, installed in accordance with manufacturer's current published recommendations in a neat manner and in accordance with standard practices of the industry.
2. All literature, installation manuals, warranty documentation, and unused accessories included in equipment and material packaging shall be handed over to NI&S with notes identifying installed location.
3. Where no specific material, apparatus, or appliance is mentioned, any standard, first-class product made by reputable manufacturer regularly engaged in the production of such material may be used providing it conforms to the contract requirements and meets the approval of NI&S.
4. Materials shall have a flame spread rating of 25 or less and a smoke developed rating of 50 or less, in accordance with NFPA 255.
5. Materials shall meet or exceed the following minimum requirements:
 - a. Where applicable, all materials and equipment shall bear the label and listing of UL. Application and installation of all listed equipment and materials shall be in accordance with such labeling and listing.
 - b. Equipment shall meet all applicable FCC regulations.
 - c. Electrical equipment and systems shall meet UL standards and requirements of the NEC. This listing requirement applies to the entire assembly. Any modifications to equipment to suit the intent of the specifications shall be performed in accordance with these requirements.
 - d. The listing of a manufacturer as "acceptable" does not include acceptance of a standard or cataloged item of equipment. All equipment and systems must conform to the specifications herein and meet the quality of the specified item.
 - e. Materials and equipment shall bear the manufacturer's name or trademark and model/serial number permanently marked.

6.4.4.8.2 Cables

1. All telecommunications cabling inside the building shall be UL listed and marked type CM, CMR, CMP, CATV, CATVR or CATVP and shall be installed in accordance with NEC articles 300-22(C)(2), 800-49, 800-50, 800-51, 800-52, 800-53, and 820. The substitutions listed in articles 800.154 and 820.154 shall be permitted.
2. All fiber optic cable inside the building shall be UL listed and marked type OFN, OFNR, or OFNP and shall be installed in accordance with NEC articles 300-22, 770-49, 770-50, 770-51, 770-52, and 770-53.

6.4.4.8.3 Factory Assembled Products

Manufacturers of equipment assemblies that include components made by others shall assume complete responsibility for the final assembled unit.

1. All components of an assembled unit need not be products of the same manufacturer.
2. Constituent parts, which are alike, shall be the product of a single manufacturer.
3. Components shall be compatible with each other and with the total assembly for intended service.
4. Contractor shall guarantee performance of assemblies of components and shall repair or replace elements of the assemblies as required to deliver the specified performance of the complete assembly.

6.4.4.8.4 Compatibility of Related Equipment

Equipment and materials installed shall be compatible in all respects with other items being furnished and with existing items so that a complete and fully operational system will result.

6.4.4.8.5 Special Tools and Kits

The Contractor shall furnish any special installation equipment, tools, or kits necessary to properly complete the telecommunications system installation. This may include, but is not limited to, tools for pulling, splicing, terminating, testing, assembly, and adjustment for cables, communication devices, stands for cable reels, cable winches, etc.

6.4.4.8.6 Firestops and Penetration Seal Materials

1. Use qualified systems to firestop through penetrations in fire-rated walls and floors for pipes, cables, conduits, ducts, inner-ducts, and cable trays.
2. Firestopping for openings through fire and smoke-rated walls and floor assemblies shall be listed or classified by an approved independent testing laboratory for “Through-Penetration Firestop Systems.” The system shall meet the requirements of “Fire Tests of Through-Penetration Firestops” designated by ASTM E814.
3. Inside all conduits, the firestop system shall consist of a dielectric, water-resistant, non-hardening, permanently pliable/re-enterable putty along with appropriate damming or backer materials (where required). The sealant must be capable of being removed and reinstalled and must adhere to all penetrants and common construction materials and shall be capable of allowing normal cable movement without being displaced.
4. Foam sealant shall meet all fire test and hose stream test requirements of ASTM E-119-73 and shall be UL classified as a wall opening protective device.
5. Provide devices/systems fire tested by a third party according to ASTM E 814 (or UL 1479) tested under positive pressure.
6. Provide only material combinations that are qualified by independent agencies based on the material’s performance when tested in a particular configuration.
7. Match the thickness (and/or depth) of firestop materials to that recommended by the manufacturer.
8. Per the UBO, all firestop material must be red in color.
9. Thickness of materials must be established by formal ASTM E814 or UL 1479 tests.
10. The basis of design for firestop for fire-rated floors and walls shall be:
 - a. Hilti Firestop Systems
 - b. 3M Fire Protection
 - c. Others as approved by the VT PM and NI&S

6.4.4.8.7 Anchoring Materials and Supports

1. Metal bars, plates, channel, tubing, etc., shall conform to ASTM Standards:
 - a. Steel plates, shapes, bars, and grating – ASTM A36
 - b. Cold-formed steel tubing – ASTM A500

- c. Hot-rolled steel tubing – ASTM A501
- d. Steel pipe – ASTM A53, Schedule 40, welded
- 2. Metal fasteners shall be zinc-coated.
- 3. Anchoring Materials:
 - a. Structural Steel
 - b. Steel Channel: Galvanized or painted
 - c. Uni-Strut

6.4.4.8.8 Grounding and Bonding Materials

- 1. Compression Connectors
- 2. Bonding Conductor: 6 AWG minimum copper
- 3. All grounding equipment shall be UL listed for that purpose.

6.4.4.9 Execution

6.4.4.9.1 General Installation Requirements

- 1. The approximate locations of existing and new telecommunications outlets, cabling and equipment will be indicated on the project drawings; however, the drawings are not intended to give complete and accurate information. Contractor is responsible to field verify existing outlets and cabling prior to submitting quote. Determine the exact location after thoroughly examining the general building plans and by actual measurements before and during construction, subject to the approval of the VT PM and NI&S.
- 2. Before construction work commences, visit the site and identify the exact routing for all horizontal pathways and equipment placement. Verify all dimensions, locating the work and its relation to existing work, all existing conditions and their relation to the work, and all man made obstructions and conditions, etc., affecting the completion and proper execution of the work as indicated in the project drawings and specifications.
- 3. If core drills are required, the exact core locations shall be identified and coordinated with the VT PM, the UBO, and the EHS Asbestos Operations and Maintenance Plan as necessary. Where required for inspection, Contractor shall retain removed cores and label with location information where the core was removed. Refer to the VT PM and the UBO for all coring requirements.
- 4. All equipment locations shall be coordinated with the VT PM, other trades and existing conditions to eliminate interference with required clearances for equipment maintenance and inspections.

5. Coordinate work with the VT PM, other trades and existing conditions to determine exact routing of cable, cable tray, hangers, conduit, etc., before fabrication and installation.
6. Install telecommunications cabling and equipment to facilitate maintenance and repair or replacement of equipment components. Provide easy, safe and code mandated clearances at equipment racks and enclosures, and other equipment requiring maintenance and operation. Coordinate with NI&S exact location and mounting height of all equipment in finished areas, such as equipment racks and termination equipment. As much as practical, connect equipment for ease of disconnecting, with a minimum of interference with other installations.
7. Coordinate ordering and installation of all materials with long lead times or having major impact on work by other trades so as not to delay the job or impact the schedule.
8. Set all equipment to accurate line and grade, level all equipment and align all equipment components. All work shall be installed level and plumb, parallel and perpendicular to other building systems and components.
9. Provide all scaffolding, rigging, hoisting and services necessary for delivery, installation, and erection of materials, equipment, and apparatus furnished into the premises. These items shall be removed from premises when no longer required. Use of University owned supplies and equipment is prohibited.

6.4.4.9.2 Workmanship

All labor must be thoroughly competent and skilled, and all work shall be executed in strict accordance with the best practice of the trades.

1. Good workmanship and appearance shall be considered of equal importance with telecommunications operation.
2. Lack of quality workmanship shall be considered sufficient reason for rejection of a system in part or in its entirety.
3. Carefully lay out all work in advance and install in a neat and workmanlike manner in accordance with recognized good practices and standards.
4. Provide workmen who are skilled in their craft and a competent Project Manager who will be on the job at all times.

6.4.4.9.3 Cables

1. Backbone and horizontal telecommunications cabling shall be placed in separate dedicated conduit pathways. Cable trays may be shared however trays shall be clearly divided between backbone and horizontal cabling. Backbone cabling must be installed prior to horizontal cables.
2. Telecommunications pathways shall be dedicated for use for NI&S voice, data and CATV cabling.
3. Horizontal cabling for other services will be allowed within the NI&S pathways per the following guidelines and acceptance of written approval from NI&S. NI&S must understand and accept the services to be used on the horizontal cabling as to not create interference with other services within the pathways. NI&S will be the sole owner of the horizontal cabling with jacks on both ends that will be installed and tested to the TIA standards on category 6 cable or better with the Siemon standard cabling. Other terminations and systems can be reviewed by NI&S but all horizontal cabling for other services must be approved in writing from NI&S.
4. All horizontal cabling terminating within a single faceplate must be routed to and terminated in the same ER or TR.
5. Consolidation points and multi-user telecommunications outlet assembly (MUTOA) configurations for horizontal cabling are not currently supported by NI&S and will not be permitted.

6.4.4.9.4 Cutting and Patching

1. Provide all cutting, patching, and core drilling, etc., as necessary for telecommunications work. Locate holes and outlets to be drilled and coordinate with work of other trades. Obtain approval of the VT PM and the UBO prior to cutting or core drilling holes in structural members.
2. Cut and drill from both sides of walls and/or floors to eliminate splaying.
3. Patch adjacent existing work disturbed by installation of new work including insulation, walls and wall covering, ceiling and floor covering and other finished surfaces. Patch openings and damaged areas equal to existing surface finish.
4. Cut openings in prefabricated construction units in accordance with manufacturer's instructions.

5. All openings shall be carefully caulked or grouted as required. Spare conduits shall be tightly capped.
6. All cutting in the building construction made necessary to admit work, repair defective materials, defective workmanship, or by neglect of the Contractor to properly anticipate requirements, shall be done in accordance with these specifications with no additional cost to the project. Patching shall be complete in every detail. Actual work involved in these repairs shall be done by skilled craftsmen in the trades involved.
7. Provide and maintain temporary partitions or dust barriers adequate to prevent the spread of dust and dirt to finished areas as required by the VT PM.

6.4.4.9.5 Concealment

Use existing conduit and cable trays where possible and practicable. Conceal all project work above ceilings and in walls, below slabs, and elsewhere throughout building. If concealment is impossible or impracticable, notify the VT PM and NI&S before starting that part of the work and install only after approval.

6.4.4.9.6 Equipment Modification

Where existing equipment is to be modified, Contractor shall furnish materials and labor as necessary to modify or add to the equipment. Modifications shall be done neatly with factory parts and assemblies approved for the application. Modification shall in no way jeopardize the compliance of existing equipment with any governing codes and regulations.

6.4.4.9.7 Firestops and Penetration Seals

1. All new and pre-existing conduit and sleeve openings used for the project shall be waterproofed or fireproofed upon cable placement through such passageways in compliance with the Virginia Statewide Building Code and UBO standards regardless of the installation of cabling or left void.
2. Patch all openings remaining around and inside all new and pre-existing conduit sleeves and cable penetrations to maintain the integrity of any fire-rated wall, floor, ceiling, etc.
3. Manufacturer's installation standards shall be closely followed (minimum depth of material, use of ceramic fiber, procedures, etc.)

4. Brick, concrete, and concrete blocks walls:
 - a. Provide metallic sleeving systems for routing of cables through these surfaces.
 - b. Ensure that sleeve extends from the front and back of the wall only far enough to attach the required bushing or collar.
 - c. Secure sleeves in place according to manufacturer's specifications.
 - d. Provide firestop seal between sleeve and wall, but do not use firestopping material to support or secure sleeve.
 - e. Firestop ends of sleeving or inner-duct after installation of cable, without exception.
5. Floor Openings:
 - a. Install firestop materials to stop openings between sleeving (or other supporting material) and core.
 - b. When coring through concrete flooring, use boots and packing materials to fashion core before installing firestopping materials.
 - c. If rectangular openings exist in concrete floors, use steel sleeving to fashion opening before installing firestopping materials.
 - d. Firestop openings in all un-used telecommunications designated slots, sleeves or ducts.
 - e. Firestop openings in slots, sleeves or ducts after installation of cable, without exception.
6. Cable Trays: All new cable tray pathways penetrating fire-rated walls should be fully closed with Hilti CFS-BL firestop bricks or equivalent fire stopping system approved NI&S and UBO.
 - a. Install the system according to the manufacturer's instructions.
 - b. Firestop materials must be easily removable if required to provide for installation of cable.
7. Fire-Rated Gypsum Walls:
 - a. Sleeve all penetrations of gypsum walls used for cable routing if cable is not in continuous conduit with Hilti Speed Sleeve product or equivalent fire stopping system approved NI&S and UBO.
 - b. Firestop seal between sleeve, conduit, or inner-duct and wall on both sides of the wall.
 - c. Use qualified firestop systems to seal penetrations in gypsum wallboard assemblies.
 - d. Verify that penetration conditions fall within the following firestop system parameters:
 - i. Hourly rating.

- ii. Opening size.
 - iii. Annular space.
- e. Install the firestop system symmetrically on both sides of the wall.
- f. Install the materials according to manufacturer-tested methods.
- 8. Other Firestopping:
 - a. Firestop through penetrations according to the guidelines for the basic construction of the two outermost layers of the combination wall.
 - b. Firestop load-bearing stud walls that are part of combination walls by enclosing (i.e., boxing) the penetration in the cavity.
 - c. Firestop partial penetrations according to the recommendations for the type of wall being penetrated.
 - d. Firestop any penetrations which violate the fire-rating integrity of vertical shafts.
 - e. Firestop openings around outlet boxes installed in fire-rated walls, on both sides.
- 9. Firestop Installation Methods:
 - a. Use drop cloths to protect other surfaces when installing.
 - b. Firestop completely around each cable individually – do not firestop bundles of cables.
 - c. If using putty around a vertical penetration, use putty to build flooring of seal, fill with fiber or rock wool to required thickness, then top with putty according to Manufacturer’s specifications.
 - d. The methods used shall incorporate qualities that permit the easy removal or addition of conduits or cables without drilling or use of special tools.
 - e. The product shall adhere to itself to allow repairs to be made with the same material and to permit the vibration, expansion and/or contraction of any items passing through the penetration without cracking, crumbling, and resulting reduction in fire rating.
- 10. The installed firestop system shall meet the requirements of “Fire Tests of Through-Penetration Firestops” designated by ASTM E814.
- 11. Seal all foundation penetrating conduits and all service entrance conduits and sleeves to eliminate the intrusion of moisture and gases into the building. This requirement also includes spare conduits.
- 12. Spare conduits shall be plugged with removable approved, fire-rated plugs.

13. All service entrance conduits through the building shall be sealed or resealed upon cable placement with a removable waterproof duct seal.
14. The firestop system shall be submitted to the VT PM prior to starting construction with a list or map of each location and system number used for the project. Inspections and approval of installed firestop systems or areas in which firestop material was or should be used will be at the discretion of the VT PM and the UBO.

6.4.4.9.8 Anchoring Methods

1. Anchor and brace all cabling, material, and equipment installed under this section as required by all codes, regulations, and standards. Provide required supports, beams, angles, hangers, rods, bases, braces, straps, struts, and other items to properly support project work. Supports shall meet the approval of the VT PM.
2. Supports shall be fabricated from structural steel, steel channel, or unistrut, rigidly bolted or welded to present a neat appearance.
3. Fastenings and supports shall be adequate to support loads with ample safety factors.
4. Fasten hanger rods, conduit clamps, outlet boxes, and pull-boxes to building structure.
5. Use toggle bolts, spider type expansion anchors, or hollow wall fasteners in hollow masonry, plaster, or gypsum board partitions and walls.
6. Use lead expansion shields or expansion anchors or preset inserts in solid masonry walls.
7. Use self-drilling anchors or lead expansion anchor on concrete surfaces.
8. Use sheet metal screws in sheet metal studs.
9. Use wood screws in wood construction.
10. In pre-cast structures, use cast-in inserts wherever possible. Expansion anchors can be used with caution, but only with prior approval.
11. In cast-in-place concrete, use expansion anchors, preset inserts, or self-drilling masonry anchors.
12. Use lead expansion anchors or preset inserts on metal surfaces.
13. Do not fasten supports to piping, ceiling support wires, ductwork, mechanical equipment or conduit.

14. Power-actuated anchors, plastic or fiber expansion anchors, and drive pin anchors are prohibited.
15. Do not drill structural steel members.
16. Any anchoring must be able to be unsecured and removed should relocation be required.
17. Where necessary and with approval from the VT PM, modify studs, add studs, add framing, or otherwise reinforce studs in metal stud walls and partitions as required to suit project work. If necessary in stud walls provide special supports from floor to structure above.
18. Support surface mounted cabinets, enclosures and panel boards with a minimum of four anchors.
19. On exterior concrete walls below grade, provide 1" steel channel stand-offs for cabinets and raceways.
20. Use stud bridges at top and bottom of cabinets and enclosures that are flush mounted on hollow drywall walls.
21. For precast panels/planks and metal decks, support communication work as determined by manufacturer and the VT PM.

6.4.4.9.9 Grounding and Bonding

1. Bond all new metallic cable shields and metallic supporting structures, in all equipment rooms and service entrances, including racks, frames, protectors and cabinets to the telecommunications grounding busbar, according to the manufacturer's specifications and as described in DCSM section 6.4.7.
2. Do not make connections between the telecommunications busbar system and building electrical grounds, or other types of connections, without approval by the VT PM.
3. Bond metallic surfaces of telecommunications hardware with #6 AWG grounding wire as straight as possible to the ground source.
4. Ensure that the grounding system is physically secured.
5. All grounding conductors leaving the ERs and TRs shall be in a separate conduit from all communication cabling.
6. All grounding items shall be installed in complete compliance with the NEC.

6.4.5 Pathways for Communications Systems

6.4.5.1 Scope of Work

Provide all services labor, materials, tools, and equipment required for the complete and proper installation of interior telecommunications pathways as called for in these specifications and related drawings.

This section includes minimum requirements and installation methods for the following:

1. EMT Conduit and Cable Tray Systems
2. Surface Metal Raceway Systems
3. Telecommunications Outlet Boxes

6.4.5.2 Quality Assurance

1. All installation work for the new interior telecommunications pathways shall be performed in a neat and workmanlike manner. All methods of construction that are not specifically described or indicated shall be subject to the control of the VT PM.
2. Equipment and materials shall be of the quality and manufacture indicated. The equipment specified is based on the acceptable manufacturers listed. Where “approved equal” is stated, equipment shall be equivalent in every way to that of the equipment specified and subject to approval of the VT PM based on submittals provided.
3. Materials and work specified herein shall comply with the applicable requirements of:
 - a. ANSI/NFPA 70 – National Electrical Code including, but not limited to, the following articles:
 - i. 250 – Grounding
 - ii. 300 – Wiring Methods
 - iii. 314 – Outlet, Device, Pull, and Junction Boxes; Conduit Bodies; Fittings; and Manholes
 - iv. 342 – Intermediate Metal Conduit: Type IMC
 - v. 358 – Electrical Metallic Tubing: Type EMT
 - vi. 386 – Surface Metal Raceways
 - vii. 392 – Cable Trays
 - viii. 770 – Optical Fiber Cables and Raceways
 - b. ANSI/TIA-568-C.0-2 – Generic Telecommunications Cabling for Customer Premises – Addendum 2, General Updates
 - c. ANSI/TIA-568-C.1 – Commercial Building Telecommunications Cabling Standard

- d. ANSI/TIA-569-B – Commercial Building Standard for Telecommunications Pathways and Spaces, including applicable addendum
- e. ANSI/TIA-607 – Commercial Building Grounding and Bonding Requirements for Telecommunications
- f. BICSI Telecommunications Distribution Methods Manual

6.4.5.3 Submittals

As-built drawings (as required per DCSM section 6.4.3).

6.4.5.4 Materials

6.4.5.4.1 EMT Conduit, Outlet Boxes, and Cable Tray Systems

1. Electrical Metallic Tubing (EMT): Electro-galvanized steel tubing 1" and larger diameter per project requirements:
 - a. Conduit joint couplings and connectors: steel double set screw indenter fittings.
 - b. Insulated metallic bushings for 1" and larger conduit.
 - c. Insulated metallic bushings with grounding lugs as required.
 - d. Conduit sweeps: minimum 10 times the conduit inside diameter.
 - e. Include required conduit straps, and hangers, heavy-duty malleable iron or steel.
 - f. Perforated pipe strap, j-hooks, bridle rings, or wire hangers are not permitted without approval.
 - g. LB fittings and plastic fittings are not permitted.
 - h. Conduits connecting one outlet box to another outlet box are not permitted.
2. Conduits feeding surface metal raceways shall be sized to allow for no greater than 40% fill when horizontal station cables supporting the raceway outlets are installed.
3. The standard outlet box shall consist of a nominal 4" × 4" × 2¼" metal box, with a 4" × 4" drywall ring with mounting holes for a double gang faceplate.
4. If a standard 4" × 4" × 2¼" metal box is not feasible, NI&S must approve the substitute in order to ensure compatibility with NI&S-supplied hardware, compliance with standards, and life-cycle maintainability.

5. Emergency phones – internal
 - a. A number of “push-to-talk” emergency phones may be located on each floor of a building. The number and location of the phones is determined by OEM and VTPD.
 - b. The physical requirements for the infrastructure to support the phones are a flush mount 4" × 4" back box with a minimum 2¼" depth. One 1-inch conduit shall be routed from the back box to within 12 inches of the nearest cable tray or homerun to the nearest communications room.
 - c. The mounting height should meet ADA requirements (coordinate with the VT PM for final box elevation). The back box faceplate mounting hole pattern shall be designed to accept the Viking 1600A push-to-talk device without the use of additional mounting equipment.
6. Pull-boxes:
 - a. Minimum 14-gauge galvanized steel with screw fastened cover and trim for flush or surface mounting as required for project. Dimensions as required for project.
 - b. Box extensions are prohibited for new construction.
 - c. Box extensions are permitted on remodel work to extend existing installations.
7. Metal Flex Conduit (1") and deep Cut-In Boxes for outlets in existing walls for remodel projects only.
8. Muletape: use polyester or aramid line with a minimum pull tensile strength of 200 pounds for installing backbone cable in riser conduits. Contractor shall install and secure muletape in all telecommunications conduits for future cabling installations.
9. Poly line: use poly pull line with a minimum pull tensile strength of 200 pounds for installing station cabling in horizontal pathways. Contractor shall install and secure poly lines in all horizontal telecommunications pathways for future cabling installations.
10. Cable Trays in Ceiling Areas:
 - a. Welded wire mesh cable system sized to accommodate all necessary project cabling and future growth.
 - b. Include components, and compatible fittings designed and manufactured by the cable tray manufacturer as required for a fully installed electrically continuous system.

- c. Include support kits, brackets, threaded rod hangers, lateral threaded rod braces, and other anchors and supports as required as specified in DCSM section 6.4.4.

6.4.5.4.2 Surface Metal Raceway Systems (SMRS)

1. Include all parts and components: base and cover, compatible fittings, insulated bushings, and supports designed and manufactured by the raceway manufacturer as required for a complete installation.
2. Where raceways will support work area outlets, provide appropriate adapters which will accept NI&S standard modular outlet jacks.
3. Where power and communications cabling must be run within the same raceway Contractor shall provide and install a solid metallic separation device manufactured specifically for the installed raceway system.

6.4.5.5 Execution

6.4.5.5.1 Inspection

1. Examine areas and conditions under which the new interior telecommunications pathways are to be installed. Provide notification, in writing, of conditions detrimental to proper completion of the work.
2. Verify field measurements and pathway routing conditions are as shown on project drawings. Provide notification, in writing, of conditions deviating from drawings.
3. Beginning of telecommunications pathway installation indicates Contractor acceptance of existing conditions.

6.4.5.5.2 Inside Cable Tray Installation

1. Cable trays provide critical cable management and allow access to horizontal wiring, which is essential for initial installation and future growth. Cable tray systems shall originate in the ER/TR and extend the entire length of the main hallways. Cable trays shall form part of a continuous cable pathway connected to the serving ER/TR.
2. Cable tray capacity shall be determined by the number of telecommunications outlets that will be served. Larger cable trays should be used in areas that have high-density telecommunications requirements. The dimensions of the cable tray may vary to accommodate the space available as long as the required capacity is maintained. Capacity requirements shall be specified by NI&S. Cable

trays shall not be filled greater than the NEC maximum fill for the tray selected.

3. The size of the cable tray may be incrementally decreased the further it extends away from the ER/TR, depending on the specific requirements of the areas being
4. There must be least 3 inches of clear space above the cable tray for access (6 inches is preferable).
5. All telecommunications cable trays shall have a minimum of 5" clearance from any sort of light fixtures.
6. No conduits, pipes, wires, threaded rod, grounding hardware or any other obstruction may penetrate the interior area of the tray where the cables are to be routed.
7. All screws, bolts, etc., used to connect the sections of tray must be installed so that they do not obstruct the installation of the cabling.
8. Cable trays are to be installed at the same elevation within the ceiling throughout the building floor.

6.4.5.5.3 Inside Conduit Installation

1. The electrical contractor will provide clean, dry and debris free conduits, to be used solely by NI&S to provision telecommunications services.
2. Conduits shall either be continuous "home-run" from the telecommunications outlet box to the equipment room, or shall be run from the outlet box and stubbed out within one foot of a cable tray that runs continuously to the equipment room. In the case of a renovation where there is no cable tray available, the conduit for the outlet box should be routed to an accessible ceiling area in the corridor.
3. The standard station-cable conduit size is 1-inch diameter minimum. The 1-inch diameter minimum may be increased depending upon the size and number of cables to be installed. Minimum conduit diameter shall be determined by NI&S based on the quantity and size of cable required.
4. Perform installation of routing hardware as specified in DCSM section 6.4.4 including anchoring and supports, grounding and bonding, firestop, etc. Use anchors for attachment to surface. Use of adhesives is prohibited.
5. The contractor shall install threaded bushings on all conduit ends.

6. The maximum conduit length is 30 m (100 ft.) between pull boxes or pull points, with no more than two 90° bends between pull boxes or pull points.
7. No unnecessary junction boxes, troughs, etc., will be installed in the conduit pathway between the outlet box and either the cable tray or the telecommunications equipment room. And the conduits are to be installed in the most direct route from the outlet box to either the cable tray or the telecommunications equipment room.
8. All conduit bends shall be sweeps with minimum bend radii as specified in the appropriate standards. There shall be no hard 90° bends.
9. The contractor shall provide a pull string (minimum pull strength of 200 pounds) in each conduit. Pull strings must be tied off at both ends of the conduit to prevent loss of the pull string.
10. All conduits from a room must be run to the same cable tray or equipment room. If there is more than one cable tray adjacent to a room, the conduits from a room cannot be “split” between the trays.

6.4.5.5.4 Surface Metal Raceway Installation

1. Place new surface metal raceway systems as shown on the project drawings.
2. Perform installation of routing hardware as specified in DCSM section 6.4.4 including anchoring and supports, grounding and bonding, firestop, etc. Use anchors for attachment to surface. Use of adhesives is prohibited.
3. Collector/distribution surface raceway shall be 25 ± 5 feet between pull-boxes. Surface raceway and boxes shall be upsized per fill in area.
4. Cut raceways square and ream ends to remove burs at raceway connections to outlets.
5. Install raceways parallel or perpendicular to building walls, floors and ceilings.
6. When installing through false ceiling, extend raceway above top of ceiling grid to a pull box feeder system or within 6 inches of the cable tray. Notch ceiling panel to size of raceway.
7. Coordinate raceway runs with other trades.
8. Ceiling tile shall be removed as necessary for the raceway installation and put back in place without damaging or dirtying any of the tiles or supporting framework. Ceiling tile shall be handled with clean hands so that no fingerprints or marks are left on the tiles. The contractor is

responsible for the cost of repair or replacement of any damaged or dirtied tiles or ceiling hardware.

9. Conduits feeding raceway shall be sized to accommodate the number of cables needed in the raceway and allow for future growth. Coordinate conduit sizing with NI&S.

6.4.5.5.5 Telecommunications Outlets

1. It is the responsibility of the VT PM to coordinate with the departments moving into the space(s), and with NI&S, to determine the location and number of telecommunications outlet boxes required in each space.
 - a. Unless otherwise noted, outlet boxes shall be located as follows (dimensions are above finished floor to center line of boxes):
 - i. Standard telecommunications outlets: 1'6"
 - ii. Top of wall-mount telephone outlets: 4'0"
 - b. All ADA standards shall be met when applicable.
 - c. Adjust outlet box locations so that they will be symmetrically located and not interfere with other equipment.
 - d. Where outlets of other types are adjacent, coordinate heights to be similar where possible.
 - e. Where outlets are located on masonry walls, adjust box location to set in corner of block or brick.
 - f. Back to back outlet boxes are not permitted. Separate boxes a minimum of 6 inches in standard walls and a minimum of 2 feet in acoustical walls.
 - g. Where conflicts are noted for outlet box locations, coordinate with the VT PM and NI&S.
2. Support outlet boxes from building construction. Do not support from other installed systems (e.g., ceiling support wiring, conduit, or raceways).
3. Telecommunications outlet boxes that support devices for wireless access points and emergency notification boards will be part of the cabling design. The electrical contractor will install conduit from the outlet box to within one foot of the cable tray, or to the ER/TR.
 - a. The Wireless Access Point outlet boxes should be placed in locations designated by NI&S. The outlet boxes should be placed above accessible ceilings where possible. If a ceiling mount is not possible then the outlet boxes should be placed 12 inches below the ceiling in the locations designated by NI&S.

- b. Notification board outlet boxes should be placed in locations designated by OEM and VTPD. The outlet boxes should be placed below the ceilings as close as possible to the reader board location as noted on the project drawings.

6.4.5.5.6 As-Built Drawings

Mark the project drawings with notations reflecting any variations from the base specifications and drawings including as-built conduit and cable tray routing.

Comply with construction drawings as-built requirements as described in DCSM section 6.4.3.

6.4.6 Exterior Underground Ducts and Raceways for Communications Systems

6.4.6.1 Scope of Work

Provide all services, labor, materials, tools, and equipment required for the complete and proper installation of exterior telecommunications pathways as called for in these specifications and related drawings.

This section includes minimum requirements and installation methods for the following:

1. Building entrance conduits.
2. ER/TR conduits extending from building entrance (where applicable).

6.4.6.2 Quality Assurance

1. All installation work for the new exterior telecommunications pathways shall be performed in a neat and workmanlike manner. All methods of construction that are not specifically described or indicated shall be subject to the control of the VT PM.
2. Equipment and materials shall be of the quality and manufacture indicated. The equipment specified is based on the acceptable manufacturers listed. Where “approved equal” is stated, equipment shall be equivalent in every way to that of the equipment specified and subject to approval of the VT PM and NI&S based on submittals provided.
3. Materials and work specified herein shall comply with the applicable requirements of:
 - a. ANSI/NFPA 70 – National Electrical Code including, but not limited to, the following articles:

- i. 314 – Outlet, Device, Pull-Boxes; Conduit Bodies; Fittings; and Manholes
- ii. 344 – Rigid Metal Conduit: Type RMC
- b. IEEE/NESC – National Electrical Safety Code
- c. NEMA Standards including, but not limited to: NEMA, RN1, 1986 PVC Externally Coated Galvanized Rigid Steel Conduit and Intermediate Metal Conduit
- d. UL Standards including, but not limited to: UL 6, 1981 Rigid Metal Electrical Conduit
- e. ANSI-C80.2, 1983 Specification for Rigid Steel Conduit, Enameled
- f. ANSI/TIA-569-B – Commercial Building Standard for Telecommunications Pathways and Spaces
- g. ANSI/TIA-607 – Commercial Building Grounding and Bonding Requirements for Telecommunications
- h. ANSI/TIA-758-A – Customer Owned Outside Plant Telecommunications Cabling Standard (including all applicable addenda)
- i. BICSI Telecommunications Distribution Methods Manual
- j. BICSI Customer-Owned Outside Plant Manual

6.4.6.3 Submittals

As-built drawings (as required per DCSM section 6.4.3).

6.4.6.4 Materials

Conduit System is Metallic Conduit:

1. Galvanized rigid conduit (GRC) with PVC coating (for building entrances).
2. Intermediate metal conduit (IMC) or rigid steel conduit (for extending entrance conduit).

6.4.6.5 Execution

6.4.6.5.1 Conduit System Placement

1. Each building is required to have two diverse building entrances for survivability. Each building entrance must have a separate inside plant pathway to ER/TRs to be specified by NI&S. The location of these building entrances shall be determined in collaboration with NI&S and the VT PM.
2. Each building entrance shall consist of a minimum of two 4-inch conduits and two 2-inch conduits of IMC or rigid steel conduit extended a minimum of 10 feet from the foundation wall and into

undisturbed soil. The exact size and number of conduits required depends on the requirements of the building being served and shall be specified by NI&S. These conduits are solely intended for the provisioning of telecommunications services by NI&S. The use of these conduits is managed and documented solely by NI&S.

3. Additional conduit shall be provisioned as required to support other services (e.g., building control systems) that run over non-NI&S cable plant.
4. The conduit pathway within the building shall be continuous rigid or intermediate conduit in cases where the distance between the termination location and the building entrance is greater than 15 m (49 feet).
5. All conduit bends will have a radius no less than 9 times the internal diameter of the conduit with a minimum radius of 36 inches.
6. No bends will be greater than 90 degrees.
7. No more than two 90° bends in a run between pulling points.

6.4.6.5.2 As-Built Drawings

Mark the project drawings with notations reflecting any variations from the base specifications and drawings including as-built conduit routing.

Comply with construction drawings as-built requirements as described in DCSM section 6.4.3.

6.4.7 Communications Equipment Room Fittings

6.4.7.1 Scope of Work

Provide all services, labor, materials, tools, and equipment required for the complete and proper installation of communications equipment within the ERs and TRs as called for in these specifications and related drawings.

This section includes minimum requirements and installation methods for the following:

1. Equipment Racks and Cable Routing Hardware
2. Copper Termination Equipment
3. Fiber Termination Equipment
4. Grounding and Bonding

6.4.7.2 Quality Assurance

All installation work in the TRs and the ERs shall be performed in a neat and workmanlike manner. All methods of construction that are not specifically described or indicated shall be subject to the control of the VT PM.

Equipment and materials shall be of the quality and manufacture indicated. The equipment specified is based on the acceptable manufacturers listed. Where “approved equal” is stated, equipment shall be equivalent in every way to that of the equipment specified and subject to approval of NI&S based on submittals provided.

Materials and work specified herein shall comply with the applicable requirements of:

1. ANSI/NFPA 70 – National Electrical Code (NEC) Articles 250, 300, and 645
2. ANSI/TIA-568-C.0-2 – Generic Telecommunications Cabling for Customer Premises- Addendum 2, General Updates
3. ANSI/TIA-568-C.1 – Commercial Building Telecommunications Cabling Standard
4. ANSI/TIA-568-B.2 – Commercial Building Telecommunications Cabling Standard – Part 2: Balanced Twisted-Pair Cabling Components, including applicable addendum
5. ANSI/TIA-568-C.3 – Optical Fiber Cabling Components Standard
6. ANSI/TIA-569-C – Commercial Building Standard for Telecommunications Pathways and Spaces
7. ANSI/TIA-604 Series – Fiber Optic Connector Intermateability Standards
8. ANSI/TIA-607 – Commercial Building Grounding and Bonding Requirements for Telecommunications
9. BICSI Telecommunications Distribution Methods Manual

6.4.7.3 Architectural Requirements

1. New TRs and ERs shall be designed in compliance with the space, electrical, and environmental requirements of ANSI/TIA-569-C – Commercial Building Standard for Telecommunications Pathways and Spaces. Smaller spaces or enclosures shall not be acceptable without prior written approval from NI&S.
2. Any or all functions of a TR may be provided by an ER.
3. The ER and TRs shall be dedicated to the telecommunications function and related support facilities. For security purposes, non-NI&S systems shall not be co-located in the ER and TRs. The ER and TRs shall not be shared with electrical installations other than those supporting

telecommunications. Equipment not related to the support of the ER or TRs (e.g., piping, HVAC systems, and pneumatic tubing) shall not be installed in, pass through, enter, or be stored in the ER or TRs.

4. ER and TR design, including location, should be developed in accordance with the security and disaster avoidance plans of the building.

6.4.7.4 Room Size and Spacing

1. There shall be a minimum of one TR per floor. Exceptions may be approved by NI&S where conditions warrant. Additional rooms shall be provided when:
 - a. The floor area to be served exceeds 10,000 sq. ft.; or
 - b. The horizontal cable distance from the ER/TR to the work area exceeds 90 m (295 feet).
2. ER and TR room sizes: ER/TR size shall be determined by NI&S based on the size and program of the building.
 - a. The minimum ER size is 10' × 15'.
 - b. The minimum TR size is 10' × 10'.
3. Special purpose rooms, such as laboratories, computer rooms and certain instructional spaces, may have a varying density of communications outlets. The size of the ER/TR serving these rooms shall be sized accordingly, as determined by NI&S.

6.4.7.5 Location

1. Each ER/TR shall be located as close as practical to the center of the area served.
2. ER/TR doors shall open directly onto a hallway to facilitate the movement of large equipment and 24×7 maintenance access.
3. Access through ER/TRs to other areas of the building, including electrical vaults, shall not be permitted.
4. ER/TRs should be located away from sources of electromagnetic interference. Special attention shall be given to electrical power supply transformers, motors, generators, x-ray equipment, and radio/radar transmitters.
5. TRs on multiple floors should be stacked over/under the ER wherever practical and as close as possible to vertical stacks. Depending on building size, there may be multiple TRs per floor. Should this be required, there will need to be multiple TR stacks.

6. ER/TRs shall be located as close as practical to the location where the vertical backbone cable pathways rise throughout the building. This requirement reduces the length and quantity of the associated pathways.
7. The ER shall not be located below grade or below the 100-year floodplain unless preventive measures against water infiltration are employed.
8. ER/TRs shall be positioned such that the risk of water infiltration from in-building systems is minimized. Possible sources of such water infiltration include domestic water supply and drains, fire sprinkler supplies, roof drains, HVAC condensation and drains.
9. ER/TRs shall be positioned away from sources of high quantities of airborne particulates (e.g., dust).

6.4.7.6 Power

1. Refer to DCSM section 6.8 for additional electrical power requirements.
2. A separate supply circuit serving the ER shall be provided and terminated in its own electrical panel in the ER. The electrical panel in the ER shall be sized to meet the projected power requirements of service to the ER and all TRs, and shall be used only to provide power to the ER/TRs.
3. Each TR shall have an electrical panel located in the TR that is fed from the electrical panel in the ER.
4. The electrical panel in the ER shall be connected to an emergency power system (generator).
5. Each ER and TR shall have two 30-amp 208-volt circuits terminated on L6-30R at rack location specified by NI&S. One circuit from ER or TR emergency panel and one from building utility power to provide redundancy on network equipment having dual power supplies.
6. Each equipment rack (ER and TR) will require one 20-amp 120-volt receptacle (5-20R) circuit originating from emergency panel in room.
7. Device boxes shall be extended to the top of each equipment rack via flexible conduit. Device boxes shall be mounted to a backplate which shall have accessible screws securing it to the rack location specified by NI&S.
8. In order to provide capacity for growth, in addition to circuits required for equipment racks, all new electrical panels for ER/TRs will also include:
 - a. One 20-amp 120-volt single-pole circuit
 - b. One 20-amp 208-volt double-pole circuit
 - c. One 30-amp 208-volt 3-phase circuit
9. Each of these circuits will be landed (terminated) on the breaker and extended into individual 4-inch junction boxes located within 12 inches of

the bottom of the panel. These junction boxes shall have blank covers with the panel and breaker information clearly marked.

10. In addition, identified and marked utility duplex outlets shall be placed at 6-foot intervals around the perimeter walls, at a height of 18 inches above the floor. Duplex utility outlets shall be provisioned on normal building power and not tied back to the electrical panel in the ER/TR.

6.4.7.7 Equipment Bonding and Grounding

1. Grounding systems installed by or for NI&S are for NI&S use only; all other use is strictly prohibited.
2. All stranded grounding conductors shall be insulated and color-coded (green with yellow trace).
3. There shall be at least one grounding conductor, the Telecommunications Bonding Backbone (TBB), for each riser stack. The TBB must be continuous and unbroken from the building central grounding point through each ER/TR in the stack. Minimum grounding conductor size is specified in the table below.
4. Virginia Tech requires that a Terminal Grounding Bar (TGB) be installed in each ER and TR and tied to the TBB. For the TGB, the basis of design shall be a Panduit grounding bar (part number GB2B0312TPI-1) or equal. The TBB shall be tapped in each ER/TR and connected to the TGB in the ER/TR. Minimum grounding conductor size for the connection between the TGB and the TBB is specified in the table below.
5. All grounding conductor terminations shall be compression crimped (no threaded compression lugs).
6. In buildings with more than one TBB, the TBBs shall be bonded together at the top floor and at a minimum of every third floor in between. Minimum grounding conductor size is specified in the following table.

7. Table of Minimum Grounding Conductor Sizes

Sizing of the Grounding Conductor Length linear m (feet)	Size (AWG)
less than 4 (13)	6
4-6 (14-20)	4
6-8 (21-26)	3
8-10 (27-33)	2
10-13 (34-41)	1
13-16 (42-52)	1/0
16-20 (53-66)	2/0
greater than 20 (66)	3/0

8. Provide and install grounding strip kits for threaded rails on front left side of each equipment rack. Basis of design shall be Panduit RGS134 or equal.
9. Ground all equipment racks and building entrance protectors to the TGB using #6 ground conductor.
10. The Contractor shall install NI&S-provided labels on grounding conductors every 5 to 20 feet as required by the cable path.
11. The Contractor shall ground all metal cable trays by connecting them to the central building grounding point per applicable specifications.

6.4.7.8 Environmental Considerations

1. ER/TRs typically require cooling year-round due to the heat generated by telecommunications equipment. The HVAC system shall be capable of maintaining the temperature between 64 °F and 78 °F in each ER/TR, with relative non-condensing humidity maintained within the range of 30% to 50%.
2. Each ER/TR shall have its own thermostat controlling the temperature for that room. Thermostat will be hard wired (no battery powered remote thermostats).
3. In some cases, the ER/TR HVAC system(s) should be on the building emergency power system (as determined by NI&S).
4. A positive air pressure shall be maintained with a minimum of one air change per hour, or as required by applicable code.
5. Heat rejection specifications for each ER/TR is determined from the number of telecommunications outlets served by each particular room and the type of equipment used to provision services. Specific heat rejection values for ER and TRs shall be coordinated with NI&S.

6. The preferred location for a Fan Coil Unit (FCU) is above the equipment room entry door to minimize the impact on the usable space within the equipment room.

6.4.7.9 Construction

1. A minimum of one wall shall be covered with 19 mm (¾-inch) A-C plywood, void free, 2.4 m (8 ft.) high and securely fastened to the wall, capable of supporting attached equipment. Plywood shall be fire-rated (fire retardant) plywood. The location is to be coordinated with NI&S.
2. Lighting shall be a minimum of 500 lux (50 foot-candles) measured 1 m (3 ft.) above the finished floor, mounted 2600 mm (8.5 ft.) minimum above finished floor.
 - a. NI&S requires that at least two lighting fixtures be installed per ER/TR. These lights shall be installed in front and behind the telecommunication equipment rack(s). The location of the lighting fixtures is to be coordinated with NI&S.
 - b. Lighting shall be controlled by one or more switches located near the entrance door(s) to the room. Dimmer switches shall not be used.
 - c. At least one light per ER/TR shall be on the building emergency lighting circuit.
3. False ceiling shall not be provided.
4. For ER/TRs, the minimum clear height in the room shall be 2.4 m (8 ft.) without obstructions.
5. Door requirements:
 - a. The door shall be a minimum of 0.9 m (36 in.) wide and 2 m (80 in.) high, without door sill, hinged to open outward (codes permitting) and fitted with a lock. The doors shall have a lever handle, store room lock, pick guard and shall be keyed to the next available core in the 102 series.
 - b. The locks for the ER and TRs shall not be on the building master keys. These locks shall be incapable of remaining in an unlocked state when the key is removed.
 - c. The door shall be equipped with an auto closing device. A door sweep shall be installed at the bottom of the door and shall be consistent with other door sweeps throughout the building.
 - d. The fire rating of the door shall be consistent with the fire rating of the walls of the room.

- e. On outward opening doors, the hinges shall be of the anti-tampering type. These hinges shall be consistent with and match similar mechanisms throughout the building.
6. Floors and walls shall be finished with a static free treatment or sealed to minimize dust; finishes shall be light in color to enhance room lighting.
7. Floor loading capacity of ER/TRs shall be at least 50 lb./sq. ft. The A/E shall verify that concentrations of proposed equipment do not exceed the floor loading limit, which may require increasing the floor loading capacity in some cases.

6.4.7.10 Fire Protection

The contractor shall provide fire protection to the room as required by code. Sprinkler heads, if required, shall be provided with wire cages to prevent accidental operation.

6.4.7.11 Pathways and Room Penetrations

1. The size and number of sleeves, conduits and/or cable trays used for riser and horizontal pathways depends on the requirements of the area served. The size and number of sleeves, conduits and/or cable trays required shall be specified by NI&S.
2. Sleeves or slots shall not be left open except during cable installation and shall be properly firestopped per applicable codes. The interior of all sleeves or slots shall be firestopped in the ER/TR by The Contractor after cable installation. Red firestopping material shall be used in all cases.
3. For any multi-story building, Contractor shall provide a schematic riser diagram depicting telecommunications infrastructure to include Outside Plant main feed, OSP redundant feed, riser conduits (noting size and quantity), cable trays and transitions from cable trays to sleeves and a typical station cable conduit and outlet box.

6.4.7.12 Submittals

As-built drawings (as required per DCSM section 6.4.3).

6.4.7.13 Materials

NI&S provides and installs the equipment and materials listed below.

6.4.7.13.1 Equipment and Materials Minimum Requirements

1. The basis of design for the floor-mount equipment rack is Ortronics Mighty Mo 6: OR-MM6716.

- a. 84" high with 44 rack spaces (1 rack space = 1¾")
 - b. EIA-310-D standard ⅝" - ⅝" - ½" hole pattern
 - c. EIA channel width of 16.25" with double-sided 12/24 tapped screw holes.
 - d. Lightweight high strength aluminum construction with black finish.
 - e. 26.25" deep base with four ¾" bolt down holes and equipped with hardware for permanent mounting on concrete floor.
 - f. Static capacity 1500 pounds.
 - g. Bend radius control with integrated cable trough and waterfalls.
 - h. Rack installation kit.
2. The basis of design for the vertical wire management is Ortronics vertical wire management cage: OR-MM6VML706.
- a. 77.18" H × 6" W × 6.13" D.
 - b. Swing out latches allow for addition/deletion of cables without affecting adjacent cables.
 - c. Mounted on the front flange of Mighty Mo 6 racks when two or more are installed in a row, on a single rack or the end of a row.
 - d. Creates a 2" channel between racks for front to back routing of equipment cables and patch cords.
 - e. Includes all mounting brackets.
3. The basis of design for the vertical grounding strip busbars for new install racks and cabinets is Panduit grounding strip for threaded rails: RGS134-1Y.
- a. Provides clean bond to any rack mounted equipment regardless of whether or not equipment has an integrated grounding terminal.
 - b. Bonds full 45 RU per rack.
 - c. Comes in EIA Universal mounting hole pattern.
 - d. Complies with U.S. and International grounding requirements.
 - e. Busbar Installation kit.
4. Cable Tray
- a. Cable tray shall be installed above the racks to facilitate routing of cables from room entrance conduits.
 - b. The basis of design for the carbon steel wire mesh cable tray with electroplated zinc finish (2" D × 12" W × 10" L) is Cablofil CF54/300EZ.
 - c. Include support kits, brackets, splice kits, end caps, etc., as required for complete installation.

5. Plywood Backboard: $\frac{3}{4}$ " A-C fire-resistant or non-combustible plywood backboard, void free, 8' high.
6. Category 6 compliant $\frac{1}{2}$ D-Rings and D-Rings wall-mount nominal 2", 4", or 6" as required.
7. Velcro cable ties for cable routing and management as required. The use of "tie-wraps" is prohibited without written authorization from NI&S.
8. Building Entrance Terminals
 - a. The basis of design is Circa BET: 188B1-100-25
 - i. 100 pair capacity
 - ii. 25' stub in/110 block out
 - iii. Accepts 5-pin Surge Protection Modules
 - b. The basis of design is Circa Surge Protection Modules: 4B1S-300
 - i. 5 PIN solid state protector module.
 - ii. Includes PTC (positive temperature coefficient) technology. Self-resetting current limiters which provide effective protection from "sneak current" faults.
9. The basis of design for the wiring block mount is the Siemon S210
 - a. The basis of design for the 19" Field Termination Panel (Tie to Building Entrance Protector) is the Siemon S210
 - b. The basis of design for the 19" Field Termination Panel (Copper Riser) is the Siemon S210-(XXX) – Use (XXX) to specify 128 or 292 pair panels sized per project.
 - c. 210 blocks shall possess the following characteristics:
 - i. Be made of flame-retardant thermoplastic, with the base consisting of horizontal index strips for terminating up to 25 pairs of conductors.
 - ii. Have detachable stand-off legs on the 128-pair base.
 - iii. Contain access openings for rear to front cable routing to the point of termination.
 - iv. Have termination strips on the base to be notched and divided into 5-pair increments.
 - v. Have clear label holders with the appropriate colored inserts available for the wiring blocks. The insert labels provided with the product shall contain vertical lines spaced on 2-, 3-, 4- and 5-pair circuit sizes and shall not interfere with running, tracing or removing patch cords. Label holders must be capable of mounting between each row of connecting blocks.

- vi. Bases are attached to 19-inch panels for rack mounting with cable management hardware.
- vii. Have connecting blocks used for either the termination of cross-connect (jumper) wire or patch cords. All connecting blocks shall have color-coded tip and ring designation markers and be of single piece construction.
- viii. Have connecting blocks with a minimum of 200 re-terminations without signal degradation below standards compliance limit.
- ix. Support wire sizes: Solid 22 to 26 AWG (0.64 to 0.40 mm), and 7-strand wires.
- d. Must be Communications Circuit Accessory Listed per UL 1863.
- e. Meet the following performance specifications:

Parameters	Performance @ 100 MHz
Insertion Loss	0.4 dB
NEXT	43.0 dB
FEXT	35.1 dB
Return Loss	20.0 dB

10. All Category 6 or 6A-termination panels shall facilitate cross-connection and inter-connection using modular patch cords and shall conform to EIA standard, 19-inch relay rack mounting requirements.
- a. The basis of design for the Cat 6 Patch Panel is Siemon: Z6-PNL-24K
 - i. Includes 24 Z-MAX™ Panel outlets.
 - ii. Made of lightweight, high strength steel with durable black finish in 24 port 1U configuration.
 - iii. Panel outlets feature angled IDC contact pattern to exploit the widest outlet cross-section to minimize alien crosstalk.
 - iv. Have a quick release lever that allows individual outlets to be easily removed even in tight installations.
 - v. Have port identification numbers on the front of the panel.
 - vi. Accommodate 24 ports for each rack mount space (1RMS = 44.5 mm [1.75 inches]).
 - vii. Come equipped with integrated rear wire management system.
 - viii. Be provided with high visibility snap-on magnifying label holders that contain paper labels or Z-MAX icons for port identification.

- b. The basis of design for the Cat 6A Shielded Patch Panel is Siemon: Z6AS-PNL-24K
 - i. Includes 24 shielded Z-MAX™ Panel outlets.
 - ii. Made of lightweight, high strength steel with durable black finish in 24-port 1U configuration.
 - iii. Panel outlets feature angled IDC contact pattern to exploit the widest outlet cross-section to minimize alien crosstalk.
 - iv. Have a quick release lever that allows individual outlets to be easily removed even in tight installations.
 - v. Have port identification numbers on the front of the panel.
 - vi. Accommodate both 24 ports for each rack mount space (1RMS = 44.5 mm [1.75 inches]).
 - vii. Come equipped with integrated rear wire management system.
 - viii. Be provided with high visibility snap-on magnifying label holders that contain paper labels or Z-MAX icons for port identification.
- 11. The basis of design for the rack mount optical fiber panel/enclosure is the rack-mount fiber cabinet by OCC #RTC2U6APB-RS2U2T. Including one RS2U2T splice kit.
 - a. The rack mount optical fiber panel/enclosure shall be constructed of all steel and equipped with either removable front and rear access to fibers or a sliding drawer to access fibers.
 - b. The rack mount optical fiber panel/enclosures shall be available with locking capabilities for security.
 - c. The rack mount optical fiber panel/enclosure shall be capable of terminating tight-buffered or loose tube optical fiber cable.
 - d. The rack mount optical fiber panel/enclosure shall provide for bend radius control throughout the panel as well as storage space for slack cabling.
 - e. The rack mount optical fiber panel/enclosure shall provide labeling space to facilitate port identification according to TIA 606A standards.
 - f. The panel/enclosure shall meet or exceed the performance criteria per ANSI/TIA-568-C.3.
 - g. The rack mount optical fiber panel/enclosure shall be equipped with optical fiber adapter panels and corresponding pre-terminated pigtail fiber optic assemblies.

12. Optical Fiber Adapter Panels and Pre-Terminated Pigtails
 - a. Field terminated fiber connectors will not be accepted. Factory polished pigtail assemblies for all fiber ends must be fusion sliced to the installed cabling.
 - b. The multimode optical fiber adapter panels and pre-terminated pigtail fiber optic cable assemblies shall be configured with six dual port multimode SC adapters.
 - c. The single-mode optical fiber adapter panels and pre-terminated pigtail fiber optic cable assemblies shall be configured with six dual port single-mode SC APC adapters.
 - d. The basis of design for fiber adapter panels is OCC.
 - i. OCC 6112DSC50G – Adapter Plate, 12-port, Dual SC, 50 μ m 10GbE Multimode, Composite Sleeve.
 - ii. OCC 6112SMDSCAPC – Adapter Plate, 12-port, Dual SC, Single-mode, Angled Polish, Ceramic Sleeve.
 - e. The basis of design for pre-terminated pigtails is OCC.
 - i. OCC P5GSC12-3M – Factory Terminated Pigtail Assembly, 12-fiber 50 μ m OM3 Color-Coded 900 μ m Multimode Fiber Stock, 3 meter lengths, Pre-Polished SC Connectors.
 - ii. OCC P8SCAPC12-3M – Factory Terminated Pigtail Assembly, 12-fiber Color-Coded 900 μ m Single-Mode Fiber Stock, 3 meter lengths, Pre-Polished SC APC Connectors.

6.4.7.13.2 Grounding and Bonding

1. #4 and #6 AWG wire suitable for grounding application.
2. All connectors and clamps shall be compression type.
3. Terminals shall be solderless compression type, copper long-barrel NEMA two bolt.
4. Telecommunications Bonding Backbone (TBB): Minimum No. 6 AWG insulated copper conductor.
5. Telecommunications Main Grounding Busbar (TMGB): Minimum 6.3 mm thick by 100 mm wide predrilled copper busbar with standard NEMA bolt hole sizing and spacing.
6. Telecommunications Grounding Busbar (TGB): Minimum 6 mm thick by 50 mm wide predrilled copper busbar with standard NEMA bolt hole sizing and spacing.
7. All grounding equipment shall be UL listed for that purpose.

6.4.7.14 Execution

6.4.7.14.1 Equipment Racks and Cable Routing Hardware In Telecommunications Rooms

1. The ERs and TRs may be equipped with some existing hardware, such as plywood backboards, grounding bus bars, equipment racks, ladder cable tray, horizontal and vertical cable management, and copper and fiber termination equipment. Existing hardware already in place will be shown on the project drawings.
2. Examine ERs, TRs, and verify conditions are as shown on project drawings. Provide notification in writing of conditions deviating from drawings or detrimental to proper completion of the work.
3. Beginning of installation in the ERs and TRs indicates contractor acceptance of existing conditions.
4. The quantity of equipment racks can vary based on the number of outlets being served by each ER/TR. At a minimum provide and install two racks per ER/TR in new construction projects.

Some renovation projects or smaller new constructions projects may require less than two racks or wall mount type racks. Obtain approval from NI&S prior to construction for all equipment room designs which include these types of non-standard projects.

5. The contractor shall obtain NI&S approval of the proposed equipment rack layout prior to installation.
6. All equipment racks shall be securely anchored to the concrete floor using minimum $\frac{3}{8}$ " hardware or as specified by rack manufacturer.
7. Install new vertical wire managers on each side and between all equipment racks.
8. Install grounding strip on front left side of each equipment rack and bond to TMGB with a minimum No. 6 AWG insulated copper conductor.
9. Install new cable tray for cable routing in the ERs and TRs above the equipment racks. All cable tray shall be securely anchored to the walls with support kits and brackets as specified by manufacturer.
10. Install plywood backboard on the walls in the ERs and TRs as required for the project. All plywood backboard shall be securely anchored to the walls.
11. All new 4-pair unshielded twisted pair (UTP) cables shall be supported using only Category 6 compliant materials and equipment: cable tray,

D-rings, and cable management hardware and shall be manufactured to allow for installation of Category 6 cables without damaging or otherwise distorting the cable's jacket material. All cable management hardware shall allow for cables to be neatly dressed-out in the ERs and TRs.

12. Bend radius of the multi-pair copper cable shall not exceed 10 times the outside diameter of the cable during installation or at rest.
13. Place copper cables transitioning between the cable trays and cabinets or racks in a neat and orderly manner per NEC 318.11(b) requirements. Velcro tie-wrap shall be used for supporting multi-pair copper cables.
14. To reduce untwisting of pairs, maintain the twisted pair cable jacket as close as possible to the point of termination.
15. Multi-pair Cable: Strip back only as much cable jacket as is minimally required to terminate on connecting hardware.
16. Use wiring block manufacturer's recommended tools with the proper-sized blades for all multi-pair copper punch downs.
17. Bend radius of the optic fiber cable shall not exceed 15 times the outside diameter of the cable during installation and 10 times the outside diameter during rest.
18. Each cable shall be individually attached to the respective splice enclosure by mechanical means. The cables strength member shall be securely attached the cable strain relief bracket in the enclosure.
19. Each fiber bundle shall be stripped upon entering the splice tray and the individual fibers routed in the splice tray.
20. Each cable shall be clearly labeled at the entrance to the splice enclosure. Cables labeled within the bundle shall not be acceptable.
21. A maximum of 12 strands of fiber shall be spliced in each tray
22. All spare strands shall be installed into spare splice trays.
23. Fiber slack shall be neatly coiled within the fiber splice tray or enclosure. No slack loops shall be allowed external to the fiber panel.
24. Firestop all sleeves and conduit openings after the cable installation is complete.
25. All building ERs and TRs require one wall-mount telephone outlet on the plywood backboard.
26. The contractor shall obtain NI&S approval of the proposed hardware equipment layout prior to installation.
27. NI&S standard rooms have copper termination equipment in the left side rack. Starting at the top with the building entrance tie cable 210

block (ER Only) and then the copper riser cable 210 blocks (TRs – top position). Install 210 horizontal cable management between each 210 block. Category 6 or 6A patch panels are installed below the 210 blocks.

28. Fiber optic panels are installed near the top of the right side equipment rack leaving at least 4 RU space below backbone fiber panels for OSP fiber panels (installed by others). The remaining space in the right side rack is reserved for network electronics.

6.4.7.14.2 Grounding and Bonding

1. Mount new Telecommunications Main Grounding Busbar (TMGB) on plywood backboard in main ER as shown on project drawings. The location for the TMGB shall be coordinated with the VT PM and NI&S.
2. Mount new Telecommunications Grounding Busbar (TGB) on plywood backboard in TRs as shown on project drawings. The location for the TGBs shall be coordinated with the VT PM and NI&S.
3. Install new TBB from the TMGB in the ER to the TGBs in the TRs as shown on project drawings. Connect the TBB to the TMGB and TGBs in accordance with TIA-607 and NEC. All grounding conductors leaving the ER and TRs shall be in a separate conduit from all communication cabling.
4. Bond all metallic surfaces of new racks, cable tray, and equipment in the TRs and ERs to the TGB or TMGB in the same room with #6 AWG grounding wire as straight as possible.
5. Bond all metallic raceways (conduit, cable tray, etc.) entering the TRs and ERs to the TGB or TMGB in the same room with #6 AWG grounding wire as straight as possible.
6. All grounding items shall be installed in complete compliance with the DCSM and NEC.

6.4.8 Backbone Cabling Requirements

6.4.8.1 Scope of Work

Provide all services labor, materials, tools, and equipment required for the complete and proper installation, splicing, and termination of new backbone cabling as called for in these specifications and related drawings.

This section includes minimum requirements and installation methods for the following:

1. Copper Backbone Cabling

2. Fiber Optic Backbone Cabling
3. Fiber Splices
4. Factory Polished Fiber Pigtailed
5. Coax Backbone Cabling

6.4.8.2 Quality Assurance

1. All backbone cabling installation, splicing, and termination shall be performed in a neat and workmanlike manner. All methods of construction that are not specifically described or indicated shall be subject to the control of NI&S.
2. Equipment and materials shall be of the quality and manufacture indicated. The equipment specified is based on the acceptable manufacturers listed. Where “approved equal” is stated, equipment shall be equivalent in every way to that of the equipment specified and subject to approval of NI&S based on submittals provided.
3. Materials and work specified herein shall comply with the applicable requirements of:
 - a. ANSI/NFPA 70 – National Electrical Code® (NEC) Articles 250, 300, 645, and 770 (latest adopted edition of the National Electrical Code®)
 - b. IEEE/NESC – National Electrical Safety Code
 - c. ANSI/TIA-568-C.0-2 – Generic Telecommunications Cabling for Customer Premises – Addendum 2, General Updates
 - d. ANSI/TIA-568-C.1 – Commercial Building Telecommunications Cabling Standard
 - e. ANSI/TIA/-568-C.2 – Commercial Building Telecommunications Cabling Standard, Part 2: Balanced Twisted Pair Cabling Components
 - f. ANSI/TIA-568-C.3-1 – Optical Fiber Cabling Components Standard
 - g. ANSI/TIA-569-C – Commercial Building Standard for Telecommunications Pathways and Spaces
 - h. ANSI/TIA-598-C – Optical Fiber Cable Color Coding
 - i. ANSI/TIA-604-3 – FOCIS 3 Fiber Optic Connector Intermateability Standard
 - j. ANSI/TIA-606 – Administration Standard for Telecommunications Infrastructure of Commercial Buildings
 - k. ANSI/TIA-607 – Commercial Building Grounding and Bonding Requirements for Telecommunications
 - l. BICSI Telecommunications Distribution Methods Manual

6.4.8.3 Submittals

As-built drawings (as required per DCSM section 6.4.3).

6.4.8.4 Materials

6.4.8.4.1 Inside Copper Backbone Cabling

1. Riser Rated Non-Plenum (CMR) Category 3 UTP, 24 AWG (Building Entrance Tie Cable): 100-Pair
2. Riser Rated Non-Plenum (CMR) Category 3 UTP, 24 AWG (ER/TR Tie Cable), if required:
 - a. 25-Pair
 - b. 50-Pair
 - c. 100-Pair
3. Riser Rated Plenum (CMP) Category 3 UTP, 24 AWG (ER/TR Tie Cable), if required:
 - a. 25-Pair
 - b. 50-Pair
 - c. 100-Pair

6.4.8.4.2 Inside Fiber Optic Backbone Cabling

1. The basis of design for the cabling is OCC OC040210-05: Riser – Indoor/Outdoor Subgrouping Hybrid 8.3/125-micron, Single-mode Optical Fiber and 50/125-micron, Multimode Optical Fiber Non Conductive Riser (OFNR) Tight-Buffer Bend Tolerant Cable
 - a. The indoor optical fiber cabling shall include 24 multimode and 24 single-mode 900-micron tight-buffered 250-micron fibers placed in a color-coded sub-unit bundles helically stranded with aramid strength elements.
 - b. The indoor/outdoor optical fiber cabling shall meet or exceed the performance criteria found in ANSI/TIA-568-C.3 and be UL listed in accordance with NEC section 770.179(a).
 - c. The indoor/outdoor optical fiber cables shall have sequential length markings printed on the cable jacket.
 - d. Operating temperature: -40 °C to 85 °C
 - e. Flex resistance: 2,000 cycles (TIA/EIA-455-104A)
 - f. Crush resistance: 2,100 N/cm (TIA/EIA-455-41A)
 - g. All single-mode and multimode fibers shall be pigtail spliced into a rack mounted
 - h. Optical fiber enclosure. Field terminations will not be permitted.

- i. The loss of fiber shall not exceed 0.4 dB per kilometer @ 1550 nm and 0.5 dB per kilometer @ 1310 nm.
- 2. The basis of design for the cabling is OCC DX048KZDZ9QP: Plenum – Indoor/Outdoor Subgrouping Hybrid 8.3/125-micron, Single-mode Optical Fiber and 50/125-micron, Multimode Optical Fiber Non Conductive Plenum (OFNP) Tight-Buffer Bend Tolerant Cable
 - a. The indoor optical fiber cables shall include 24 multi-mode and 24 single-mode 900-micron tight-buffered 250-micron fibers placed in a color-coded sub-unit bundles helically stranded with aramid strength elements.
 - b. The indoor/outdoor optical fiber cables shall meet or exceed the performance criteria found in ANSI/TIA-568-C.3 and be UL listed in accordance with NEC section 770.179(a).
 - c. The indoor/outdoor optical fiber cables shall have sequential length markings printed on the cable jacket.
 - d. Operating temperature: -40 °C to 85 °C
 - e. Impact resistance: 1,000 impacts (TIA/EIA-455-25A)
 - f. Crush resistance: 1,500 N/cm (TIA/EIA-455-41A)
 - g. All single-mode and multimode fibers shall be pigtail spliced into a rack mounted optical fiber enclosure. Field terminations will not be permitted.
 - h. The loss of fiber shall not exceed 0.4 dB per kilometer @ 1550 nm and 0.5 dB per kilometer @ 1310 nm.

6.4.8.4.3 Inside Coaxial Backbone Cabling

- 1. The basis of design is Commscope 4564604 | F11SSV: Riser Rated Non-Plenum (CMR or CATVR) RG11 (Series 11), Quad Shield non-flooded cable capable of certification up to 1 GHz.
- 2. The basis of design is Commscope 4103304/10 | 2287K: Riser Rated Plenum (CMP or CATVP) RG11 (Series 11), Quad Shield non-flooded cable capable of certification up to 1 GHz.
- 3. The basis of design for connectors used for terminations is Thomas & Betts F11 QS Long shank hex-type crimp Series 11 connectors. Cables and connectors shall be capable of certification up to 1 GHz.

6.4.8.4.4 Coaxial Devices and Equipment

Provided and installed by NI&S after coaxial backbone cabling commissioning.

6.4.8.4.5 Backbone Cabling Installation Materials, Equipment, and Tools

1. Furnish all required materials, equipment, and tools necessary to properly complete the backbone cabling system installation including, but not limited to: tools for pulling, splicing, and terminating the cables, mounting hardware, cable ties, bolts, anchors, clamps, hangers, kits of consumables, lubricants, communication devices, stands for cable reels, cable winches, etc.
2. Muletape: Polyester or aramid fiber.

6.4.8.5 Execution

6.4.8.5.1 Inspection

1. Examine areas and conditions under which backbone cabling is to be installed. Provide notification, in writing, of conditions detrimental to proper completion of the work.
2. Verify field measurements and cable routing and termination conditions are as shown on drawings. Provide notification, in writing, of conditions deviating from drawings.
3. Beginning of backbone cabling installation indicates Contractor acceptance of existing conditions.

6.4.8.5.2 Copper UTP Building Entrance Tie and Backbone Cabling Installation

1. Perform all backbone cabling installation in conformance with manufacturer's installation guidelines.
2. Ensure that maximum pulling tensions of specified cables are not exceeded and cable bends maintain the proper radius during placement.
3. Failure to follow appropriate guidelines for cabling installation will require the Contractor to provide, in a timely fashion, the additional material and labor necessary to rectify the situation. This shall apply to any and all damages sustained to the cables during installation.
4. Field verify all cable measurements and install all backbone cables in such a manner as to avoid any and all mid-span splices. No mid-span splices are allowed except as specified and shown on project drawings.
5. Pull and secure new muletape through all conduit while pulling new backbone cable.

6. The Contractor shall be responsible for all damage to the cable during placement.
7. Do not roll or store cable reels without an appropriate underlay.
8. All new copper backbone cables shall be attached to the cable pathway systems or plywood backboards with cable ties for strain relief.
9. Backbone telecommunications cabling shall be placed in dedicated pathways
10. Terminate cables so as not to pull tight on terminating equipment.
11. Ensure that all splice closures are properly sealed for protection of the cable and splices.
12. Neatly and permanently label all backbone cables with the cable number at both ends and at all splice locations.
13. Firestop all sleeves and conduit openings after the cable installation is complete.
14. Plug ends of conduit entering buildings with watertight conduit caulking compound after cable installation is complete to ensure foreign matter does not enter the buildings.
15. Test, label, and document the final backbone cable installation, including cable footages, on the as-built drawings.

6.4.8.5.3 Copper UTP Building Entrance Tie and Backbone Cable Terminations

1. Install copper UTP backbone cabling through conduit or other pathways as shown on the drawings.
2. Refer to project drawings for building specific pair count for backbone copper.
3. Terminate cable pairs on S210 connecting blocks in each ER and TR following the industry standard color code sequence.

6.4.8.5.4 Fiber Backbone Cabling

1. Cables shall be dressed and terminated in accordance with the recommendations made in ANSI/TIA-568-C.0 and/or ANSI/TIA-568-C.1, manufacturer's recommendations, and best industry practices.
2. Backbone cables shall be installed separately from horizontal distribution cables.
3. A plastic or nylon pull cord with a minimum test rating of 90 kg (200 lb.) shall be co-installed with all cable installed in any conduit.

4. Where cables are housed in conduits, the backbone and horizontal cables shall be installed in separate conduits.
5. Exposed cables must be OFNP rated if installed in an air return plenum. Riser rated cables shall be installed in metallic conduit if installed in an air return plenum.
6. Where backbone cables and distribution cables are installed in a cable tray, backbone cables shall be installed first and bundled separately from the horizontal distribution cables.
7. Backbone cables spanning more than three floors shall be securely attached at the top of the cable run with a wire mesh grip and on alternating floors or as required by local codes.
8. Vertical runs of cables shall be supported to messenger strand, cable ladder, or other method to provide proper support for the weight of the cable.
9. Large bundles of cables and/or heavy cables shall be attached using metal clamps and/or metal banding to support the cables.
10. The cable's minimum bend radius and maximum pulling tension shall not be exceeded. Refer to manufacturer's requirements.
11. Each optical fiber cable shall be individually attached to the respective enclosure by mechanical means. The cables strength member shall be securely attached the cable strain relief bracket in the enclosure.
12. Each optical fiber cable shall be clearly labeled at the entrance to the enclosure. Cables labeled within the bundle shall not be acceptable.
13. Each fiber bundle shall be stripped upon entering the splice tray and the individual fibers routed in the splice tray.
14. A maximum of 12 strands of fiber shall be spliced in each tray.
15. All spare fiber strands shall be installed into spare splice trays.
16. Fiber slack shall be neatly coiled within the fiber splice tray or enclosure. No slack loops shall be allowed external to the fiber panel.
17. Perform fusion splicing of multimode fiber strands on SC APC factory polished pigtails with loss ≤ 0.02 dB at 850 nm.
18. Perform fusion splicing of single-mode fiber strands on SC APC factory polished pigtails with loss ≤ 0.05 dB at 1310 nm.
19. Terminate fiber strands on connectors and in termination equipment (shelves and panels) as specified in manufacturer's color code sequence.
20. Place "Caution Fiber" tags every 5 feet along the fiber cable route within the ER/TR.

6.4.8.5.5 Safety

The contractor must comply with VT regulations for asbestos, lead, and confined spaces.

6.4.8.5.6 As-Built Drawings

Mark the project drawings with notations reflecting actual cable lengths and any variations from the base specifications and drawings including as-built cable routing.

Comply with construction drawings as-built requirements as described in DCSM section 6.4.3).

6.4.9 Horizontal Cabling Requirements

6.4.9.1 Scope of Work

1. Provide all services, labor, materials, tools, and equipment required for the complete and proper installation and termination of new horizontal “station” cabling as called for in these specifications and related drawings.
2. The horizontal portion of the telecommunications cabling system extends from the work area telecommunications outlet to the termination in the TR or ER.
3. This section includes minimum requirements and installation methods for the following:
 - a. Copper Horizontal Cabling
 - b. Work Area Faceplates
 - c. Copper Modular Jacks
 - d. Coaxial Horizontal (Drop) Cabling

6.4.9.2 Quality Assurance

1. All horizontal “station” cable installation and termination shall be performed in a neat and workmanlike manner. All methods of construction that are not specifically described or indicated shall be subject to the control of the VT PM and NI&S.
2. Equipment and materials shall be of the quality and manufacture indicated. The equipment specified is based on the acceptable manufacturers listed. Where “approved equal” is stated, equipment shall be equivalent in every way to that of the equipment specified and subject to approval of NI&S based on submittals provided.

3. Materials and work specified herein shall comply with the applicable requirements of:
 - a. ANSI/NFPA 70 – National Electrical Code including, but not limited to, the following articles:
 - i. 300 – Wiring Methods
 - ii. 645 – Information Technology Equipment
 - iii. 725 – Class 1, Class 2, and Class 3 Remote Control, Signaling, and Power-Limited Circuits
 - iv. 770 – Optical Fiber Cables and Raceways
 - v. 800 – Communications Circuits
 - b. ANSI/TIA/EIA-568-C.0-2 – Generic Telecommunications Cabling for Customer Premises – Addendum 2, General Updates
 - c. ANSI/TIA-568-C.1 – Commercial Building Telecommunications Cabling Standard
 - d. ANSI/TIA-568-B.2 – Commercial Building Telecommunications Cabling Standard – Part 2: Balanced Twisted-Pair Cabling Components, including applicable addendum
 - e. ANSI/TIA/EIA-568-C.3-1 – Optical Fiber Cabling Components Standard
 - f. ANSI/TIA-569-C – Commercial Building Standard for Telecommunications Pathways and Spaces
 - g. ANSI/TIA-604 Series – Fiber Optic Connector Intermateability Standard
 - h. ANSI/ICEA S-83-596 – Fiber Optic Premises Distribution Cable
 - i. BICSI Telecommunications Distribution Methods Manual

6.4.9.3 Submittals

As-built drawings (as required per DCSM section 6.4.3).

6.4.9.4 Materials

6.4.9.4.1 Copper Horizontal Cabling

1. Category 6, 4-Pair Unshielded Twisted Pair (UTP) Indoor Cabling
 - a. The basis of design is Siemon System 6 Riser Cable 9C6R4-E3-02-R(X)A, White Sheath Color. (X-Indicates Payout System – Contractor may use REELEX or Reel).
 - b. The basis of design is Siemon System 6 Plenum Cable 9C6P4-E3-06-R(X)A, Blue Sheath Color. (X-Indicates Payout System – Contractor may use REELEX or Reel).

- c. Riser and Plenum rated cable characteristics and specification are as follows:
 - i. Jacket features reverse sequential numbering.
 - ii. Round jacket.
 - iii. Center isolation member reduces NEXT loss by limiting pair-to-pair contact.
 - iv. Be available in both 1000' REELEX boxes and 1000' reels.
 - v. ISO/IEC 11801:2002 (Category 6), ANSI/TIA 568-C.2 – 2009, UL CMR/CMP and CSA FT4/FT6 standards compliant.
 - vi. Transmission performance verified by UL.
 - vii. RoHS compliant.
 - viii. Meet the following electrical specifications:

DC Resistance	< 9.38 Ω / 100 m
DC Resistance Unbalanced	5%
Mutual Capacitance	5.6 nF / 100 m
Capacitance Unbalanced	< 330 pF / 100 m
Characteristic Impedance (ohms)	1-100 Mhz: 100 \pm 15% 100-520 MHz: 100 \pm 22%
NVP	CMP - 70% CMR - 65%
LCL	30 - 10Log(f/100) dB
Delay Skew	\leq 35 ns / 100 m

- 2. Category 6A, 4-Pair Foil over Unshielded Twisted Pair (F/UTP) Indoor Cabling
 - a. The basis of design is Siemon System 6A Riser Cable 9A6R4-A5-05-R1A, Yellow Sheath Color. (Available Payout System – Reel).
 - b. The basis of design is Siemon System 6A Plenum Cable 9A6P4-A5-06-R1A, Blue Sheath Color. (Available Payout System – Reel).
 - c. Riser and Plenum rated cable characteristics and specification are as follows:
 - i. Round cable jacket available in both CMR and CMP options with a nominal cable O.D. of less than or equal to 7.37 mm (0.290 inches).
 - ii. Have a construction comprised of four pairs of 23 AWG solid bare copper conductors utilizing a center isolation member to maintain pair geometry for optimal NEXT performance.
 - iii. Have a Mylar tape surrounding the cable pairs with a drain wire with an aluminum foil tape surrounding the drain wire.
 - iv. Have a rip cord installed under the jacket for jacket removal.
 - v. Be available in both 1000' and 3000' reels.

- vi. ISO/IEC 11801Ed 2.2, IEC 61156-5 Ed 2.0, ANSI/TIA 568-C.2, UL CMR/CMP and CSA FT4/FT6 standards compliant.
- vii. Transmission performance verified by UL.
- viii. RoHS compliant.
- ix. Meet the following electrical specifications:

DC Resistance	< 17.0 Ω / 100 m
DC Resistance Unbalanced	5%
Mutual Capacitance	5.6 nF / 100 m
Capacitance Unbalanced	< 330 pF / 100 m
Characteristic Impedance (ohms)	1 \leq f \leq 100: 100 \pm 15% 100 \leq f \leq 750: 100 \pm 22%
NVP	CMP - 72% CMR - 68%
LCL	30 - 10Log(f/100) dB
Delay Skew (ns)	\leq 45

6.4.9.4.2 Coaxial Horizontal Cabling and Connectors

Coaxial RG-6, Quad Shield capable of certification up to 1 GHz.

1. The basis of design is General Cable C5889.41.02: Inside Rated (CM or CATV), White Sheath Color.
2. The basis of design is General Cable C3525.41.86: Plenum Rated (CMP or CATVP), White Sheath Color.
3. The basis of design for connectors used for terminations is Thomas & Betts Snap-N-Seal 360-degree true radial compression connectors. Hex-crimp connectors will not be accepted. Cable and connectors shall be capable of certification up to 1 GHz.

6.4.9.4.3 Work Area Faceplates

1. The basis of design is Siemon CT-8-FP-SS-L: Double Gang, Stainless Steel CT-Style Faceplate for Category 6 Option
 - a. Allow couplers to be removed from the front of the faceplate.
 - b. Allow UTP couplers to pass through faceplates even after termination.
 - c. Have write-on designation labels for circuit identification together with a clear plastic cover.
 - d. Easily removable designation label covers which can be removed without use of tools.
 - e. Have optional modular furniture adapters available.
 - f. Must be Communications Circuit Accessory Listed per UL 1863.

2. The basis of design is Siemon MX-FP-S-06-SS-L: Double Gang, Stainless Steel MAX-Style Faceplate for Category 6A Option
 - a. Outlet to be 6-port double-gang configuration.
 - b. Allow modules to be removed from the front of the faceplate.
 - c. Allow UTP modules to pass through faceplates even after termination.
 - d. Have write on designation labels for circuit identification together with a clear plastic cover.
 - e. Feature easily removable designation label covers which can be removed without use of tools.
 - f. Have optional modular furniture adapters available.
 - g. Faceplate to be stainless steel versions with designation label option.
 - h. Must be certified by UL to United States Standards.

6.4.9.4.4 Copper Modular Jacks

1. The basis of design is Category 6, 8-Position, 8-Conductor UTP Outlet: Siemon CT6 Coupler CT-C6-XX (The “XX” indicates outlet color; coordinate with the A/E and VT PM prior to ordering for project.)
 - a. Be available in black, white, red, gray, yellow, blue, green, orange, ivory, bright white, light ivory and alpine white.
 - b. Have available a gravity-feed (45 degree angled) design with angled shroud to protect connection and help control patch cord bend radius.
 - c. Utilizes TRI-BALANCE™ technology with optimized pair balance design and linear crosstalk response to address applications up to 250 MHz.
 - d. Have 310 style insulation displacement connectors with quadrant pair isolation and a Pyramid™ wire entry system.
 - e. Allow termination with a single conductor impact tool.
 - f. Modules should feature category markings on front and rear of outlet.
 - g. Be backwards compatible to allow lower performing categories of cables or connecting hardware to operate to their full capacity.
 - h. Have rear protective strain relief caps with side or rear entry, which can be installed onto cable before or after termination.
 - i. Support industry standards for T568A or T568B wiring options on each individual outlet.
 - j. Be removable from the front with the faceplate mounted in place.

- k. Must have a hinged door option on angled version for areas having excessive airborne contaminants.
 - l. Provide color-coded snap-in icons available for circuit identification.
 - m. Be constructed of high impact, flame-retardant thermoplastic.
 - n. Allow for a minimum of 200 terminations without signal degradation below standards compliance limits.
 - o. Must be certified by UL to United States Standards.
2. The basis of design is Category 6A, 8-Position, 8-Conductor F/UTP Outlet: Siemon Z-Max Shielded Outlet Z6A-S(XX) (The “XX” indicates outlet color. Coordinate with the A/E and VT PM prior to ordering for project).
- a. Exceed category 6A component compliance through the frequency range of 1 to 250 MHz with usable bandwidth to 500 MHz.
 - b. Provide full integration of cable shielding through the termination process of the outlet.
 - c. Be available in black, white, red, gray, yellow, blue, green, orange, ivory, bright white, light ivory and alpine white.
 - d. Universal design allows the same outlet to be mounted in flat or angled orientation.
 - e. Basis of design for termination shall be a Siemon Z-tool to ensure fast and simple terminations.
 - f. Have an available spring door allowing one handed operation.
 - g. Have a lacing module that offers linear lacing and zero-cross termination, which eliminates pair crossing.
 - h. Have available termination tool included with each box of 20 outlets.
 - i. Be backwards compatible to allow lower performing categories of cables or connecting hardware to operate to their full capacity.
 - j. Support industry standards for T568A or T568B wiring options on each individual outlet.
 - k. Allow installation from the front or rear of the faceplate, and allow for the jack to pass through the faceplate without re-termination.
 - l. Provide color-coded, snap-in icons available for circuit identification.
 - m. Allow for a minimum of 5 terminations without signal degradation below standards compliance limits.
 - n. Have a bezel constructed of high impact, glass reinforced nylon.

- o. Have, as an option, an outlet, which can be mounted into an IEC 60603-7 compliant opening (keystone).
- p. Must be certified by UL to United States Standards.

6.4.9.4.5 Installation Materials, Equipment, and Tools

Furnish all required materials, equipment, and tools necessary to properly complete the horizontal copper and CATV coaxial cabling system installation including, but not limited to: tools for pulling and terminating the cables, mounting hardware, Velcro cable ties (plastic tie wraps will not be accepted), bolts, anchors, clamps, hangers, kits of consumables, lubricants, communication devices, stands for cable reels, cable wenchers, etc.

6.4.9.5 Execution

6.4.9.5.1 Inspection

1. Examine areas and conditions under which horizontal cable is to be installed. Provide notification, in writing, of conditions detrimental to proper completion of the work.
2. Verify cable routing and termination conditions are as shown on drawings. Provide notification, in writing, of conditions deviating from drawings.
3. Beginning of horizontal cable installation indicates Contractor acceptance of existing conditions.

6.4.9.5.2 Horizontal Cabling Installation

1. Install faceplates and copper jacks at each work area outlet location as indicated on the project drawings. Place the jacks in the faceplates beginning with position A and placing the copper jacks before the CATV coaxial adapter jacks. Place blank covers in the unused openings on each faceplate. Faceplates shall be secured with mechanical fasteners. Adhesive fasteners shall not be allowed.
2. Unless otherwise noted on project drawings, each portal (station location) will be fed with one Cat 6 or Cat 6A cable as directed per project design.
3. Each Wireless Access Point will be fed with two Cat 6 or Cat 6A cables as directed per project design.
4. Each Message Board will be fed with one Cat 6 or Cat 6A cable as directed per project design.

5. Each Indoor Emergency Phone will be fed with one Cat 6 or Cat 6A cable as directed per project design.
6. Copper cabling to Outdoor Emergency Phone locations will be provided by NI&S.
7. Install copper cable from each work area outlet location indicated on the drawings to the nearest TR or ER as indicated on the project drawings.
8. Perform all horizontal cable installation in conformance with manufacturer's installation guidelines.
9. Ensure that maximum pulling tensions of specified cables are not exceeded and cable bends maintain the proper radius during placement.
10. For outlet locations in walls, floor, and overhead, the horizontal cable distribution design uses conduit or surface raceway to the outlet location with conduit, surface raceway, and/or cable tray in the ceiling space to the TR or ER. Coordinate as necessary with electrical contractor for placement of horizontal cable pathways and outlet boxes.
11. Horizontal telecommunications cabling shall be placed in dedicated pathways separate from backbone and other cabling.
12. All horizontal cabling terminating within a single faceplate must be routed to and terminated in the same ER or TR.
13. Install new Poly line in all conduits while pulling in new horizontal cables.
14. Ceiling tile shall be removed as necessary for the cable installation and put back in place without damaging or dirtying any of the tiles or supporting framework. Ceiling tile shall be handled with clean hands so that no fingerprints or marks are left on the tiles. The contractor is responsible for the cost of repair or replacement of any damaged or dirtied tiles or ceiling hardware.
15. For cable penetration of ceiling tiles, the holes must be placed along the ceiling tile edge.
16. All cables in the ceiling space:
 - a. Shall be supported in conduit or in the cable tray and shall not droop or hang outside of cable tray.
 - b. Shall not be run "wild" (unsupported by conduit or cable tray) for distances greater than 6 inches.
 - c. Shall not be attached to the suspended ceiling structure or laid directly on the ceiling grid as a means of support.

- d. Shall not be supported by or attached by any means to fire sprinkler heads or delivery systems, any environmental sensor, or the exterior of any conduit or raceway.
 - e. Shall be routed at right angles to the electrical power circuits where the cable is not enclosed in conduit or in cable tray.
17. The total length of any horizontal station cable from the jack location to the equipment room termination panel shall not exceed 90 meters.
18. Maintain the following clearances from EMI sources:
- a. Unshielded power lines or equipment less than or equal to 5 kVA near cable in open or non-metal pathway: 12 inches.
 - b. Unshielded power lines or equipment greater than 5 kVA near cable in open or non-metal pathway: 24 inches.
 - c. Unshielded power lines or equipment less than or equal to 5 kVA near cable in grounded metal pathway: 6 inches.
 - d. Unshielded power lines or equipment greater than 5 kVA near cable in grounded metal pathway: 12 inches.
 - e. Power lines enclosed in grounded metal conduit less than or equal to 5 kVA near cable in grounded metal pathway: 3 inches.
 - f. Power lines enclosed in grounded metal conduit greater than 5 kVA near cable in grounded metal pathway: 6 inches.
 - g. Lighting fixtures near cable in open or non-metal pathway: 12 inches.
 - h. Lighting fixtures near cable in grounded metal conduit: 6 inches.
 - i. Motors or transformers near cable in non-metal pathway: 48 inches.
 - j. Motors or transformers near cable in grounded metal pathway: 36 inches.
19. Manage slack to avoid excess cable or kinking.
20. Do not splice or bridge tap the cable.
21. All cables shall be tied and dressed neatly with a minimum bend radius of 10 times the cable diameter. Provide necessary hardware to maintain proper bend radius at corners.
22. All cables shall be firmly held in place. Fastenings and supports shall be adequate to support loads with ample safety factors.
23. Where cable ties or other fastening devices are utilized, the Contractor shall ensure that the cables are not deformed by over tightening. Mechanical cable tie installation tools are not allowed. The use of Velcro-type cable ties is required. Plastic ties will not be accepted.

24. Failure to follow appropriate guidelines for cable installation will require the Contractor to provide, in a timely fashion, the additional material and labor necessary to rectify the situation. This shall apply to any and all damages sustained to the cables during installation.
25. The Contractor shall be responsible for all damage to the cable during placement.
26. Cables with jackets that are chaffed or burned exposing internal conductor insulation or have any bare copper (shiners) shall be replaced.
27. Do not roll or store cable reels without an appropriate underlay.
28. Neatly and permanently label all horizontal cables with the cable number at both ends.
29. Firestop all sleeves and conduit openings after the cable installation is complete.
30. Test, label, and document final horizontal cable installation including outlet numbering on as-built drawings.
31. Remove existing cable and terminations that will no longer be used as specified and shown on project drawings. Coordinate as necessary with electrical contractor for removal of existing horizontal cable pathways and outlet boxes.

6.4.9.5.3 Copper Cable Termination

1. At the work area outlet and the jack panel in the ER/TR, terminate all pairs of the each copper horizontal cable on the jack with TIA T568B pin-pair assignments.
2. All un-used Category 6 or Category 6A jack inserts packaged with the jack panels in the ER/TR are to be left in the manufacturer's original packaging and attached to the rack or wire manager for future cabling installations.
3. Terminate all pairs of each copper horizontal cable.
4. All cables shall be terminated so as not to pull tight on the terminating equipment.
5. Do not untwist cable pairs more than 0.5 inches when terminating.

6.4.9.5.4 Coaxial Horizontal Cabling

1. All drops are to be home-run from the nearest TR/ER to the face plate with no drop splitters or amplifiers to be used.
2. Drop connectors shall be compression type as listed in DCSM section 6.4.9.4. "Hex-crimp" connectors are not allowed.

3. Connector type is to be determined by the jacket material of the cable being terminated.

6.4.9.5.5 As-Built Drawings

Mark the project drawings with notations reflecting actual cable outlet numbering and any variations from the base specifications and drawings.

Comply with Construction Drawings as-built requirements in DCSM section 6.4.3.

6.4.10 Testing, Identification, and Administration

6.4.10.1 Scope of Work

1. Provide all services, labor, materials, tools, and equipment required for complete and proper testing, certification, identification, and administration of the installed telecommunications cabling as called for in these specifications and related drawings.
2. This section includes minimum requirements and installation methods for the following:
 - a. Copper Cable Testing and Testers
 - b. Fiber Optic Cable Testing and Testers
 - c. Labels and Labeling
 - d. Documentation
3. NI&S will provide the outlet numbers (H-Links) to the Contractor upon request. The Contractor must request this information at least four weeks prior to installing horizontal cabling. Requests for H-Links should be made through the VT PM.

6.4.10.2 Quality Assurance

1. All testing procedures and testers shall comply with applicable requirements of:
 - a. ANSI/TIA-568-C.0-2 – Generic Telecommunications Cabling for Customer Premises – Addendum 2, General Updates
 - b. ANSI/TIA-568-C.1 – Commercial Building Telecommunications Cabling Standard
 - c. ANSI/TIA-568-B.2 – Commercial Building Telecommunications Cabling Standard – Part 2: Balanced Twisted-Pair Cabling Components, including applicable addendum
 - d. ANSI/TIA/EIA-568-C.3-1 – Optical Fiber Cabling Components Standard
 - e. TIA-455 Series – Fiber Optic Test Procedures

- f. TIA-526 Series – Optic Fiber Systems Test Procedures
 - g. TSB 140-04 – Additional Guidelines for Field-Testing Length, Loss and Polarity of Optical Fiber Cabling Systems
2. Identification and administration work shall comply with applicable requirements of:
- a. ANSI/TIA-568-C.0-2 – Generic Telecommunications Cabling for Customer Premises – Addendum 2, General Updates
 - b. ANSI/TIA-568-C.1 – Commercial Building Telecommunications Cabling Standard
 - c. ANSI/TIA-568-B.2 – Commercial Building Telecommunications Cabling Standard – Part 2: Balanced Twisted-Pair Cabling Components, including applicable addendum
 - d. ANSI/TIA-568-C.3-1 – Optical Fiber Cabling Components Standard
 - e. ANSI/TIA-569-A – Commercial Building Standard for Telecommunications Pathways and Spaces
 - f. ANSI/TIA-598-A – Optical Fiber Cable Color Coding
 - g. ANSI/TIA-606 – Administration Standard for Telecommunications Infrastructure of Commercial Buildings
 - h. BICSI Telecommunications Distribution Methods Manual

6.4.10.3 Submittals

Test reports and As-built drawings (as required per DCSM section 6.4.3).

6.4.10.4 Materials

6.4.10.4.1 Multi-Pair Backbone Cabling and Category 6 Testing

1. All category 6 field-testing shall be performed by the Contractor with an approved level III balanced twisted-pair field test device.
2. All multi-pair UTP backbone cables shall be 100% tested by The Contractor for continuity.
3. Category 6 balanced twisted-pair horizontal cables shall be 100 percent tested according to ANSI/TIA/EIA-568-B.1. Test parameters include wire map plus ScTP shield continuity (when present), length, NEXT loss (pair-to-pair), NEXT loss (power sum), ELFEXT loss (pair-to-pair), ELFEXT loss (power sum), return loss, insertion loss, propagation delay, and delay skew.
 - a. Test Equipment Criteria
 - i. All balanced twisted-pair field testers shall be factory calibrated each calendar year by the field test equipment manufacturer as stipulated by the manuals provided with the

field test unit. The calibration certificate shall be provided for review prior to the start of testing.

- ii. Autotest settings provided in the field tester for testing the installed cabling shall be set to the default parameters.
 - iii. Test settings selected from options provided in the field testers shall be compatible with the installed cable under test.
- b. Provide the following 4-connector guaranteed channel performance:

Parameter	UTP Cat 6 Cable System Performance				
	100 MHz	200 MHz	250 MHz	350 MHz	550 MHz
Insertion Loss (dB)	19.6	28.7	32.6	36.1	51.3
NEXT Loss (dB)	47.3	42.8	41.3	40.1	36.2
PSNEXT Loss (dB)	45.3	40.8	39.3	38.1	34.2
ACR (dB)	27.7	14.1	8.8	4.0	-15.1
PSACR (dB)	25.7	12.1	6.8	2.0	-17.1
ACR-F (dB)	30.8	24.8	22.8	21.3	16.0
PS ACR-F (dB)	28.8	22.8	20.8	19.3	14.0
Return Loss (dB)	22.5	21.0	20.5	20.1	18.8
Propagation Delay (ns)	517.6	516.5	516.3	516.1	515.5
Delay Skew (ns)	≤ 35	≤ 35	≤ 35	≤ 35	≤ 35

6.4.10.4.2 Category 6A Testing

1. All 500 MHz category 6A field-testing shall be performed by The Contractor with an approved level 111e balanced twisted-pair field test device.
2. All multi-pair UTP backbone cables shall be 100% tested by The Contractor for continuity.
3. 500 MHz Category 6A balanced twisted-pair horizontal and backbone cables shall be 100 percent tested according to ANSI/TIA/EIA-568-C.1. Test parameters include wire map plus F/UTP (ScTP) shield continuity (when present), length, NEXT loss (pair-to-pair), NEXT loss (power sum), ELFEXT loss (pair-to-pair), ELFEXT loss (power sum), return loss, insertion loss, propagation delay, and delay skew.
 - a. Test Equipment Criteria
 - i. All balanced twisted-pair field testers shall be factory calibrated each calendar year by the field test equipment manufacturer as stipulated by the manuals provided with the field test unit. The calibration certificate shall be provided for review prior to the start of testing.

- ii. Autotest settings provided in the field tester for testing the installed cabling shall be set to the default parameters.
 - iii. Test settings selected from options provided in the field testers shall be compatible with the installed cable under test.
- b. Provide the following 4-connector guaranteed channel performance:

Parameter	UTP Cat 6A Cable System Performance								
	100 MHz	200 MHz	250 MHz	300 MHz	400 MHz	500 MHz	550 MHz	625 MHz	700 MHz
Insertion Loss (dB)	19.8	29.0	32.8	36.4	43.0	48.9	51.8	55.8	62.3
NEXT Loss (dB)	44.3	39.8	38.3	37.1	35.3	33.8	33.2	32.4	31.2
PSNEXT Loss (dB)	42.3	37.8	36.3	35.1	33.3	31.8	31.2	30.4	29.2
ACR (dB)	24.5	10.8	5.5	.07	-7.8	-15.1	-18.6	-23.5	-31.1
PSACR (dB)	22.5	8.8	3.5	-1.3	-9.7	-17.1	-20.6	-25.5	-33.1
ACR-F (dB)	27.8	21.8	19.8	18.3	15.8	13.8	13.0	11.9	10.3
PS ACR-F (dB)	24.8	18.8	16.8	15.3	12.8	10.8	10.0	8.9	7.3
Return Loss (dB)	20.1	18	17.3	16.8	15.9	15.2	14.9	14.5	14.0
Propagation Delay (ns)	538.0	537.0	536.0	536.0	536.0	536.0	536.0	535.0	535.0
Delay Skew (ns)	≤ 45	≤ 45	≤ 45	≤ 45	≤ 45	≤ 45	≤ 45	≤ 45	≤ 45

6.4.10.4.3 Optical Fiber Cable Testers

1. Field test instruments for multimode fiber cabling shall meet the requirements of ANSI/TIA/EIAA-526-14-A.
2. Field test instruments for single-mode fiber cabling shall meet the requirements of ANSI/TIA/EIAA-526-7.
3. Multimode Light Source
 - a. Meet the launch requirements of ANSI/TIA-455-78B achieved within the field test equipment or by use of an external mandrel wrap (as described in clause 6.4 of ANSI/TIA-568-C.0) with a Category 1 light source.
 - b. Provide stabilized 850 nm and 1300 nm +/- 20 nm wavelength LED light source.
 - c. Spectral width of sources shall be ≤ 50 nm of 850 nm wavelengths and ≤ 140 nm for 1300 nm wavelengths.
 - d. Output of light source shall be 8 MW for 62.5 or 50 μm core optical fiber as appropriate.
 - e. Output stability +/- 0.40 dB from 0 to 50 °C.

- f. Long term output stability +/- 0.10 dB at 25 °C.
 - g. Connector types shall include: SC.
4. Single-mode Light Source
 - a. Provide stabilized 1310 nm and 1500 nm +/- 20 nm wavelength Laser light source.
 - b. Output stability +/- 0.40 dB from 0 to 50 °C.
 - c. Long term output stability +/- 0.10 dB at 25 °C.
 - d. Connector types shall be SC APC.
 5. Optical Power Meter
 - a. Calibrated against National Institute of Standards and Technology (NIST) standard.
 - b. Provide 850 nm, and 1300 nm +/- 20 nm selectable wavelength test capability.
 - c. Measurement range from 10 to -60 dBm.
 - d. Accuracy +/- 5% at 0 to -50 dBm.
 - e. Accuracy +/- 10%, 10 to 0 dBm and -50 to -60 dBm.
 - f. Resolution 0.01 dB.
 - g. Connector types shall include: SC.
 6. Optical Time Domain Reflectometer (OTDR)
 - a. Dual selectable wavelength: 850/1300 nm for multimode.
 - b. Dual selectable wavelength: 1310/1550 nm for single mode.
 - c. Selectable Cable Index of Refraction.
 - d. Visual fault locator for continuity checks and dead zone fault location.
 - e. Front display and printer connection for hard-copy documentation.
 - f. Equipped with launch jumper cable of sufficient length to offset entry “dead zone.”
 7. Connector types shall include: SC and SC APC.

6.4.10.4.4 Labels

1. Faceplate labels shall be printed and supplied by the Contractor with a Dymo Electronic Labelmaker 5000 or equivalent with prior approval from NI&S.
2. Labels for cable marking: vinyl substrate with a white printing area and a clear “tail” that self laminates the printed area when wrapped around the cable. If cable jacket is white, provide cable label with printing area that is any other color than white, so that the labels are easily distinguishable.

3. Pre-printed labels shall meet legibility, defacement, exposure and adhesion requirements of UL 969.
4. Handwritten labels are not allowed.

6.4.10.5 Execution

6.4.10.5.1 Copper Cable Testing

1. Test 100% of installed backbone copper cabling for:
 - a. Wire Map
 - b. Length
2. Perform the following Permanent Link tests for 100% of installed Category 6 and Category 6A horizontal cabling as described in ANSI/TIA-568-C.1, section 6.3 and ANSI/TIA-568-B.2, Annex E:
 - a. Wire Map
 - b. Length
 - c. Insertion Loss
 - d. Pair-To-Pair NEXT Loss
 - e. Propagation Delay
 - f. Delay Skew
3. Perform the following Permanent Link tests for 100% of installed Category 6 and Category 6A horizontal copper cabling as described in ANSI/TIA-568-C.0, section 6.3 and ANSI/TIA-568-B.2, Annex E:
 - a. PSNEXT Loss
 - b. Pair-To-Pair ELFEXT
 - c. PSELFEXT
 - d. Return Loss
4. Cross-connects from horizontal to backbone cabling will not be in place for these tests.
5. The wire map test shall verify pair to pin termination at each end and check for connectivity errors. The wire map shall indicate the following for each of the eight conductors:
 - a. Continuity to the remote end
 - b. Shorts between any two or more conductors
 - c. Reversed pairs
 - d. Split pairs
 - e. Transposed pairs
 - f. Any other miswiring
6. The maximum length of the permanent link for horizontal cable shall be 90 meters. Shorten any cable runs as required at no additional cost to the project.

7. Replace and or repair cable and terminations as necessary to assure 100% passing performance specifications.
8. Final testing shall be scheduled and conducted in the presence of the NI&S and cable manufacturer's representative as specified in DCSM section 6.4.3.
9. Submit electronic and printed test results reports for each multi-pair backbone copper cable to NI&S (through the VT PM).
10. Submit electronic and printed test results reports for each copper cabling permanent link to both NI&S (through the VT PM) and horizontal copper system manufacturer per Siemon Structured Cabling System warranty requirements.

6.4.10.5.2 Optical Fiber Cable Testing

1. Test all installed fiber optic strands after splicing and termination with an OTDR (Optical Time-Domain Reflectometer) per TIA-455-61 and TSB-140:
 - a. End-to-end bi-directional signature trace with fault finding, connection point reflections, fiber bend, pressure point locations, etc.
 - b. One wavelength, 1300 nm for multimode strands.
 - c. One wavelength, 1550 nm for single-mode strands.
 - d. Multimode fiber connector losses ≤ 0.5 dB at 850 nm.
 - e. Single-mode fiber connector losses ≤ 0.2 dB at 1310 nm.
 - f. Multimode fiber splice losses ≤ 0.3 dB at 850 nm.
 - g. Single-mode fiber splice losses ≤ 0.2 dB at 1310 nm.
 - h. Localized attenuation shall not exceed 0.5 dB at any point.
2. Test link attenuation of all installed fiber optic strands after splicing and termination in accordance with ANSI/TIA-568-C.0, section 6.4 and Annex E, and TSB-140.
 - a. One direction with an optical light source and an optical power meter.
 - b. Test at two wavelengths to account for attenuation differences due to wavelength:
 - i. 850 nm and 1300 nm for multimode strands
 - ii. 1310 nm and 1550 nm for single-mode strands
 - c. Test multimode strands in accordance with TIA-526-14-A, Method B, One Reference Jumper.

- d. For multimode strands, wrap reference jumper around mandrel to remove high-order mode transient losses as specified in ANSI/TIA-568-C.0, section 6.4, Table 3.
 - e. Test Single-mode strands in accordance with TIA-526-7, Method A.1, One Reference Jumper.
 - f. The total attenuation budget for each fiber cable length (end-to-end) shall equal the allowed attenuation for the fiber (0.2 dB per km times the length in km) plus the attenuation for each splice and connector. For example, a cable length of 3 km with 1 splice and 2 connectors would have an attenuation budget of $(3 \text{ km} \times 0.2 \text{ dB/km}) + (1 \times 0.2 \text{ dB}) + (2 \times 0.2 \text{ dB}) = 1.2 \text{ dB}$.
3. Fibers that are broken or damaged shall be replaced at no cost to VT and replaced fiber optic cables shall be re-tested.
 4. Final testing shall be scheduled and conducted in the presence of the NI&S and cable manufacturer's representative as specified in DCSM section 6.4.3.
 5. Submit electronic and printed OTDR test results reports for each fiber optic cable strand to both NI&S (through the VT PM) and fiber system manufacturer per OCC fiber warranty requirements.

6.4.10.5.3 Horizontal Cable Identification and Labeling

Neatly and permanently label all copper and fiber optic cables with the cable number at both ends within 2 inches of termination end.

NI&S provided standard outlet numbers (H-Links) are to be used for labeling faceplates, 210-blocks, patch panels, and fiber terminations.

6.4.10.5.4 As-Built Drawings

Mark the project drawings with notations reflecting any variations from the base specifications and drawings including as-built numbering for the outlets on the floorplans.

As-built drawings must include the NI&S provided H-Link outlet information as described in this section.

Comply with Construction Drawings as-built requirements as described in DCSM section 6.4.3.

6.4.11 Classroom A/V Services

In each assembly area where audible communication is integral to the use of the space, include modular assistive listening systems. For minor renovations,

installing rack plates into lecterns may be considered. These plates should include a microphone input, audio output, and HDMI output connected to the space's audio-visual system. Consult the classroom audio-visual team, part of the Office of the University Registrar, for further information and coordination with other stakeholders (particularly the Office of Equity and Accessibility and Services for Students with Disabilities).

6.4.11.1 Classroom Design Standards

6.4.11.1.1 Small Classroom Standard (25-40 seats)

1. ADA compliant lectern with space to securely house A/V equipment and a shelf for the document camera
2. Sources
 - a. The basis of design shall be Cable Cubby (with at least one 120-volt outlet)
 - i. 12' HDMI cable to ensure enough distance to reach anywhere on the lectern or to an adjacent table and be wired into the rack
 - ii. 12' VGA cable to ensure enough distance to reach anywhere on the lectern or to an adjacent table and be wired into the rack
 - iii. Space to add cables if necessary (USB for lecture capture/web conferencing, Ethernet, USB-C, etc.)
 - b. HD document camera
 - c. Blu-ray player with clamping shelf; the basis of design for the clamping shelf shall be Middle Atlantic.
 - d. Wireless presentation solution; the basis of design shall be Crestron Airmedia.
 - e. Optional wall-mounted PTZ camera for lecture capture and web conferencing with USB conversion (landing on a USB hub with USB audio solution to provide a single USB output to the cable cubby)
3. Destination
 - a. Ceiling-mounted laser WUXGA 5000 lumen (or better) projector
 - b. 16:10 electric projector screen (wall-mounted or ceiling-mounted depending on room)
 - c. Optional wall-mounted 60" monitor to be used as a confidence monitor or for student collaboration
4. Control system and midpoint distribution; the basis of design shall be Crestron and IDTech products as listed below:
 - a. Crestron series 3 processor (if not built into midpoint, e.g., DMPS)

- b. Crestron touch panel mounted with swivel mount table top kit (e.g., TSW-760)
 - c. IDTech WCR3227-512 magnetic card reader for access control
 - d. Crestron midpoint (DM or NVX solution, typically DMPS for the smaller rooms)
 - e. Optional button panel to control the 60" monitor outside of class time
5. Audio
- a. Wireless lapel microphone
 - b. Amplifier (70 V or 8 ohm depending on room)
 - c. Speakers (Ceiling mounted or surface mounted depending on room)
 - d. Assisted listening system capability (installed or optional audio output for portable units)
 - e. Optional ceiling mounted microphone system for lecture capture and web conferencing with USB conversion (landing on a USB hub with USB camera solution to provide a single USB output to the cable cubby)
6. Environment
- a. Non-ghosting whiteboards are preferred (as many as possible in most cases). See DCSM section 5.16.4.
 - b. Optional cable pathways
 - i. Floor box under the lectern with two 1-inch conduits for A/V stubbing out above the ceiling in the same room
 - ii. Two 1-inch conduits stubbing out above the ceiling coming down to a 2-gang electrical box on the wall covered with a pass-through plate
 - iii. Surface mount wiremold on the wall coming down and connecting to floor molding that ends under the lectern. The basis of design for the floor molding shall be Connectrack (or similar).
 - iv. No disconnect plates
 - c. 120 V duplex building power for lectern located inside or beneath lectern needs to be on the same building phase as the projector and optional monitor
 - d. 120 V duplex building power located at the projector location to be on the same building phase as the lectern and optional monitor

- e. Optional 120 V duplex building power located at the monitor location to be on the same building phase as the lectern and projector
- f. 1RU mounted power strip with ten to twelve 20-amp outlets
- g. Campus network connectivity provided at the lectern location (two ports)

6.4.11.1.2 Large Classroom Standard (above 40 seats)

1. ADA compliant lectern or table with space to securely house A/V equipment and a shelf for the document camera
2. Optional equipment rack in a closet depending on room complexity
3. Sources
 - a. The basis of design shall be Cable Cubby (with at least one 120-volt outlet)
 - i. 12' HDMI cable to ensure enough distance to reach anywhere on the lectern or to an adjacent table and be wired into the rack
 - ii. 12' VGA cable to ensure enough distance to reach anywhere on the lectern or to an adjacent table and be wired into the rack
 - iii. Space to add cables if necessary (USB for lecture capture/web conferencing, Ethernet, USB-C, etc.)
 - b. HD document camera
 - c. Blu-ray player with clamping shelf; the basis of design for the clamping shelf shall be Middle Atlantic.
 - d. Wireless presentation solution; the basis of design shall be Crestron Airmedia.
 - e. Optional additional inputs from around the room depending on the room needs
 - f. Optional wall-mounted PTZ camera for lecture capture and web conferencing with USB conversion (landing on a USB hub with USB audio solution to provide a single USB output to the cable cubby)
4. Destination
 - a. Amount of destinations varies depending on room needs
 - b. Ceiling-mounted laser WUXGA 6000 lumen (or better) projector depending on room needs
 - c. Large 16:10 electric projector screens (wall-mounted or ceiling-mounted depending on room)

- d. Optional wall-mounted 60" monitor(s) to be used as a confidence monitor or for student collaboration.
- 5. Control system and midpoint distribution; the basis of design shall be Crestron and IDTech products as listed below:
 - a. Crestron series 3 processor (if not built into midpoint, e.g., DMPS)
 - b. Crestron touch panel mounted with swivel mount table top kit (e.g., TSW-1060)
 - c. IDTech WCR3227-512 magnetic card reader for access control
 - d. Crestron midpoint (DM or NVX solution, typically DM-MD solution for larger rooms)
 - e. Optional button panel(s) to control the 60" monitor(s) outside of class time
- 6. Audio
 - a. Audio DSP with USB output capabilities (landing on a USB hub with USB camera solution to provide a single USB output to the cable cubby)
 - b. Wireless lapel microphone
 - c. Wireless handheld microphone
 - d. Amplifier (70 V or 8 ohm depending on room)
 - e. Speakers (ceiling-mounted or surface-mounted depending on room)
 - f. Installed assisted listening system
 - g. Optional ceiling mounted microphone system for lecture capture and web conferencing landing on the audio DSP
- 7. Environment
 - a. Non-ghosting whiteboards are preferred (as many as possible in most cases). See DCSM section 5.16.4.
 - b. Optional cable pathways
 - i. Floor box under the lectern with two 1" conduits for A/V stubbing out above the ceiling in the same room
 - ii. Two 1" conduits stubbing out above the ceiling coming down to a 2-gang electrical box on the wall covered with a pass-through plate
 - iii. Surface mount wiremold on the wall coming down and connecting to floor molding that ends under the lectern. The basis of design for the floor molding shall be Connectrack (or similar).
 - iv. No disconnect plates

- c. 120 V duplex building power for lectern/teaching table located inside or beneath lectern/teaching table needs to be on the same building phase as the projector location(s), equipment closet equipment rack, and optional monitor(s)
- d. 120 V duplex building power located at the projector location(s) needs to be on the same building phase as the lectern/teaching table, equipment closet equipment rack, and optional monitor(s)
- e. 120 V quad building power located at the equipment closet equipment rack location needs to be on the same building phase as the lectern/teaching table, projector location(s), and optional monitor(s)
- f. Optional 120 V duplex building power located at the monitor location(s) to be on the same building phase as the lectern/teaching table, equipment closet equipment rack, and projector location(s)
- g. 1RU mounted power strip with ten to twelve 20-amp outlets located at lectern/teaching table
- h. Vertically mounted power strips with an adequate amount of 20-amp outlets installed in the equipment rack
- i. Campus network connectivity provided at the lectern location (two ports)
- j. Campus network connectivity provided at the equipment closet equipment rack location (two ports)

6.4.11.2 Scope of Work

1. For renovations on classroom spaces assigned by the Registrar's Office (in-house)
 - a. Choose rooms for renovation
 - b. Engineer and design the system
 - c. Create a signal flow diagram of the system
 - d. Create a Request for Proposal (RFP) for all the products within the system
 - e. Review pricing from vendors and select lowest price that best matches the RFP
 - f. Receive, asset tag, and inventory everything that comes in
 - g. Schedule and install the equipment
 - i. Install projector and screen
 - ii. Install speakers
 - iii. Install cabling pathways where necessary

- iv. Pull wiring point-to-point for the system
 - v. Install equipment into lectern and wire
 - h. Commission the system
 - i. Program the system; the basis of design for in-house programming shall be Crestron.
 - i. In-house Crestron programming
 - ii. In-house GUI design
 - j. Monitor and maintain the system (VTEye)
- 2. For new construction of classroom spaces assigned by the Registrar's Office (Contractor)
 - a. Work with A/E and A/V consultant on
 - i. Classroom layout
 - ii. Floor box and conduit locations
 - iii. System design to match our current standards
 - iv. Create an equipment list for all the product within the system
 - b. Review pricing from vendors and select lowest price that best matches RFP
 - c. Check in on the installation of the equipment
 - d. Asset tag and inventory all the equipment
 - e. Commission the system
 - f. Program the system; the basis of design for in-house programming shall be Crestron.
 - i. In-house Crestron programming
 - ii. In-house GUI design
 - g. Monitor and maintain the system (VTEye)
- 3. For classroom, lab, conference, or informal learning spaces that are not assigned through the Registrar's Office (in house or contractor)
 - a. Consult with A/E, A/V consultant, and stakeholders on
 - i. Classroom layout
 - ii. Floor box and conduit locations
 - iii. Recommend a system design to match our current standards
 - iv. Help create an equipment list for all the product within the system
 - b. If requested, review pricing with stakeholders from vendors and select lowest price that best matches RFP
 - c. If requested, check in on the installation of the equipment

6.5 ELEVATORS

1. Perform work in accordance with the following:
 - a. ANSI A117.1 – Specifications for Making Buildings and Facilities Accessible to and Usable by Physically Handicapped People.
 - b. ANSI/ASME A17.1 – Safety code for Elevators and Escalators.
 - c. ANSI/UL 108 – Fire Tests of Door Assemblies.
2. Submittals shall include:
 - a. Shop drawings,
 - b. Schematic wiring diagram,
 - c. Product data and maintenance manuals. Maintenance manuals shall minimally include:
 - i. Operating and maintenance instructions,
 - ii. Parts listing,
 - iii. Recommended parts inventory listing,
 - iv. Purchase source listing for major and critical components, and
 - v. Emergency instructions.
 - d. Provide two sets of maintenance manuals for the Virginia Tech use after approval of all shop drawings.
 - e. Contract documents shall require a letter from the elevator manufacturer (on manufacturer's letterhead) verifying that the manufacturer acknowledges and will comply with all requirements of the specifications relative to repair and maintenance tools. Specifically, the letter shall include language that acknowledges the acceptance of the following:
 - i. Any and all maintenance diagnostic tools, shop drawings, electrical schematic wiring diagrams and any access codes and passwords required to perform any maintenance function over the life of the equipment such as diagnostics, adjustments or parameter reprogramming shall be provided to the VT PM on the Date of Substantial Completion.
 - ii. Tools may be handheld or built into the control system and shall function for the life of the equipment without the requirement to return them to the Manufacturer.
 - iii. Provide complete product data manuals and operations and maintenance manuals and maintenance training manuals including diagnostics instructions for troubleshooting the microprocessor system.
 - iv. The University shall not be required to sign licensing agreements related to the use of maintenance or repair tools.

- f. Provide a letter from the elevator contractor certifying that the all components of the elevator system are compatible with each other and are appropriate for the application.
3. It is the intention of the University to obtain competitive bids for all maintenance and repair services and material for the elevator provided. Accordingly, the use of proprietary equipment or equipment requiring the use of any proprietary items throughout the life of the equipment is unacceptable. In addition, any special tools, prints, technical data, layouts, hardware, software, etc., required throughout the life of the equipment and which cannot be obtained from multiple suppliers, must be provided by the manufacturer to the University at substantial completion of the project.
4. Per the elevator code, ASME A17.1, Virginia Tech's main campus is located in seismic zone 2 and therefore elevators are required to be provided with seismic protection. Confirm with the A/E for seismic zone requirements for projects not on Virginia Tech's main campus.
5. Elevator shall be provided with a 12-month warranty which begins on the date of Substantial Completion.

Warranty shall include full maintenance services as described herein:

- a. Warranty Service – Full maintenance services to be included under this contract and at no additional cost to Virginia Tech shall minimally include:
 - i. monthly preventive maintenance performed during normal working hours,
 - ii. repair or replacement of worn or defective parts or components,
 - iii. lubricating, cleaning, and adjusting as required for proper elevator operation in conformance with specified requirements and
 - iv. 24-hours-per-day, 7-days-per-week emergency callback service, and
 - v. performance of annual test due during the 12-month service period.
- b. Exclude only repair or replacement due to misuse, abuse, accidents, or neglect caused by persons other than Installer's personnel.
- c. Full maintenance shall be provided by skilled, competent employees of the elevator Installer for a period of 12 months following Date of Substantial Completion at no additional cost to the Virginia Tech.
6. For buildings of 20,000 square feet or larger it is preferable to have at least two elevators. In research, lab or dining facilities, one of these two elevators shall be of freight size and capacity. Residential buildings shall be provided with a minimum of two passenger elevators and one freight-sized elevator.
7. Service car elevators shall be used instead of freight type cars and shall serve the penthouse.

8. All elevator cabs will include security cameras (camera provided by VT). See DCSM section 6.4.
9. Protective pads will be designed and supplied for all cars.
10. All new, non-residential buildings provided with elevator service shall have at least one elevator sized and configured to accommodate an ambulance type stretcher (76" × 24") in the horizontal position. New residence halls shall have all elevators configured to accommodate an ambulance type stretcher. Where existing elevators are replaced, the above criteria shall be met where possible.
11. Elevator provider shall have a full service facility located within 100 miles of elevator installed location and be able to respond to service calls within 2 hours.
12. Elevator equipment rooms shall not be used for access to roofs or other parts of the building unless elevator equipment is fenced or walled in.
13. If emergency power is provided to the building, at least one elevator shall be on the emergency power circuit. If the building has more than one elevator, only one elevator is required to be on emergency power but the other elevator(s) shall be provided with an emergency lowering system.
14. For new buildings, elevator machine rooms shall be temperature-controlled spaces that provide proper operating temperatures and humidity levels for the elevator equipment provided. Cooling design temperature shall not exceed 76 °F. Note that if the elevator is on emergency generator then the cooling equipment is required to be served by the emergency generator also. For renovation projects without existing mechanical cooling for the elevator service, air-conditioning shall be added to the elevator cabinet with the design temperature not to exceed 76 °F.
15. Elevator subcontractor shall provide all signage as required by applicable codes. Signage shall be engraved in hall call stations and cab control stations. Signage shall be engraved in English and in Braille and shall be mounted to meet ADA requirements.
16. The basis of design for residence hall elevators shall be 5WL® textured stainless steel cab interiors.
17. All elevators shall be provided with emergency lighting.
18. Cab overhead lights and cab operating panels shall be LED type.
19. If an elevator is installed in a residential building, provide elevator with walk-off carpet. If an elevator is installed in an E&G Building, provide elevator with either walk-off carpet or removable rubber flooring.
20. Elevator machine rooms shall be drawn at a minimum of ¼" scale. Show all equipment to be provided by others. All required clearances with text or faded dashed lines. Provide all power and lighting as required by the latest adopted codes.

21. Hydraulic elevator machine rooms shall be located adjacent to elevator shaft.
22. Elevator controller shall be solid-state microprocessor based for dispatch and motor control.
23. All buttons, hall call stations, light fixtures, car stations, position indicators, etc., shall be vandal resistant type.
24. All Phase I and II fire service shall be keyed to barrel type key EX-515.
25. In buildings with more than three stories, provide position indicators on each floor.
26. Elevator pits shall have sump pumps and adequate drains to prevent the accumulation of water. Drains shall not be connected to building sewers. Provide water sensors in elevator pit. Siemens to monitor water sensors, oil sensor and sump pump general alarm in elevator pits.
27. Provide conduit for telephone wiring from the telephone backboard to the elevator controller. Power for the elevator telephone must be on an emergency circuit.
28. All electric motors on elevator or conveying equipment shall be "Premium Efficiency" Installed.
29. Elevator disconnect shall be located as close as possible to non-hinged side of elevator machine room door.
30. Elevator travelling cables shall be provided with an integral CAT 6 for installation of security cameras.
31. Provide all elevators with remote monitoring capability through NI&S to elevator service monitoring company.

6.5.1 Electric Traction Elevators

1. Traction-type elevators shall have machinery located overhead; basement machines not allowed.
2. Traction elevators shall be installed where necessary to serve more than three stories.

6.5.2 Hydraulic Elevators

1. Jack cylinder shall be installed inside a PVC pipe and capped on the lower end.
2. Install all elevator hydraulic piping above ground. Provide shut off valve in machine room for maintenance purposes. All hydraulic piping for elevators shall be minimum schedule 80 construction.
3. Hydraulic elevators not on emergency generator shall be provided with emergency battery back-up elevator lowering devices such that in a power

outage, the elevator will lower to the main landing and doors will open so that entrapped passengers can safely exit.

4. Hydraulic elevators shall be installed to serve no more than three stories.

6.5.3 Escalators and Moving Walks

Escalators and moving walks shall not be installed in Virginia Tech facilities.

6.5.4 Wheelchair Lifts

Wheelchair lifts shall not be installed in Virginia Tech facilities.

6.6 PLUMBING

6.6.1 Common Work Results for Plumbing

1. Backflow prevention devices shall be installed at the service connection of all new buildings. Backflow prevention devices (BFP) shall be installed inside the building. Provide two parallel BFPs at the service connection to allow servicing/testing of equipment without having to shut down the water service to the entire building. Minimum redundancy for each BFP is 50%.
2. There is an existing domestic hot water utility on campus that is fed from the power house. No new buildings shall connect to the existing utility. If a renovation is done to an existing building that is already connected to the utility, the domestic hot water service shall only be used with permission of the Engineering Operations.
3. When designing a domestic hot water system for a new building or capital renovation, the energy source should be selected carefully. Assuming all options are available onsite, the energy source preference is as follows:
 - a. Campus Low-Pressure Campus Steam (See DCSM section 6.6.5.4.)
 - b. Campus High-Pressure Campus Steam (See DCSM section 6.6.5.4.)
 - c. Natural Gas (See DCSM sections 6.6.5.5 and 6.6.5.6.)
 - d. Propane (See DCSM sections 6.6.5.5 and 6.6.5.6.)
 - e. Electricity (See DCSM section 6.6.5.7.)
 - f. If there is a system that has a significant daytime water heating demand, consider the use of solar thermal domestic water heating.
4. A central domestic hot water system is more efficient and easier to maintain than having many individual water heaters installed throughout a building. As such, designing a system with many individual heaters in lieu of a single hot water generation system can only be done with the approval of Engineering Operations.
5. All domestic hot water systems shall be designed with hot water expansion tanks that are properly sized for the application.

6. To reduce the chance of legionella growing in domestic hot water storage tanks, any hot water tank or storage-type water heater shall be sized and set up for a minimum hot water storage temperature of 140 °F. A secondary mixing valve shall be used to ensure that the leaving hot water temperature to fixtures will never be above 120 °F.
7. All central domestic hot water systems shall be designed with a hot water recirculation system. The recirculation pump shall have the ability to be scheduled via BAS system or with a timer. BAS scheduled is preferred.

6.6.2 Plumbing Equipment Insulation

1. Any plumbing equipment that will be insulated shall be insulated in a way that the equipment can be easily removed for maintenance without damaging the insulation. The basis of design shall be a custom insulation blanket by Insultech or equal.
2. Large domestic hot water storage tanks shall be factory insulated with spray-on insulation when available.

6.6.3 Instrumentation and Control for Plumbing

See DCSM section 6.3 for BAS design standards.

6.6.4 Plumbing Piping

1. Pipes and Pipe Fittings:
 - a. ABS piping is unacceptable.
 - b. Do not install heating hot water or other similar service piping susceptible to freezing in overhanging soffit areas.
 - c. On both domestic water and mechanical systems, no sweat connection valves shall be used. Use only flanged or threaded valves.
 - d. Allowable methods for connecting pipe in new construction include:
 - i. Threaded
 - ii. Flanges
 - iii. Soldered (2" pipe or smaller)
 - iv. Brazed (2½" pipe or larger)
 - v. Welded
 - e. Mechanically joined pipe, press-type connections, are allowed for post-construction repair projects only. They are not allowed for new construction.
 - f. No mechanically formed tee connections or couplings shall be used on domestic water piping systems.

2. Valves:
 - a. Include sufficient zone isolation/shut off valves in domestic cold and hot water piping to allow maintenance and replacement of equipment without shutting down entire building.
 - b. Install valves on every floor for all lines that penetrate floors from below.
 - c. Install valves on all branch lines off of main lines.
 - d. Install valves on all lines at locations such that each floor can be isolated independent of main building.
 - e. Any fixture that mixes hot and cold domestic water shall not allow counter flow into the piping system from the fixture due to pressure differences. Must operate if one side is off or if difference is 1 to 80 psig.
 - f. Install control valves where they can be reached from the floor where possible, and ensure that the valves are accessible without obstructions.
 - g. Provide isolation valves for all individual wet labs and research spaces, accessible from outside the lab space.
3. Piping Specialties: Pipe chases shall be provided in sufficient size to accommodate maintenance personnel (at least 3 feet wide). Do not locate pipe chases in custodial closets.

6.6.5 Domestic Water

6.6.5.1 Domestic Water Piping

1. Shut off valves are required on each floor, on take-offs from all vertical risers, and at the connection to each piece of equipment.
2. Dielectric fittings shall be used with connecting piping of dissimilar metals. Brass fittings and dielectric nipples are acceptable fittings, but brass valves shall not be used as the dielectric connection.
3. Drain valves shall be installed in accessible locations at all low points in the piping system to permit drainage and servicing.
4. No iron pipe fittings (including galvanized) shall be used in any potable water system.
5. No more than four slip joints per fixture shall be permitted.
6. PEX piping is not approved for use in University buildings.

6.6.5.2 Domestic Water Packaged Booster Pump

1. A booster pump package shall be required if the utility cold water supply pressure cannot maintain 40 psi pressure at the highest fixture in the building.
2. If the booster pump is supplying the main domestic feed for a building and the maximum demand flowrate for the booster pump is 75 GPM or

- greater, the package shall have at least 2 pumps, each sized for a minimum of 60% of the demand flowrate.
3. Any booster pump package shall be installed with a manual bypass.
 4. All packaged booster pumps shall be equipped with individual pump VFDs.
 5. All booster pumps shall be installed with a bladder style hydro-pneumatic storage tank.
 - a. If possible, install hydro-pneumatic tank at the high point of the system.
 - b. Hydro-pneumatic tank shall be connected to the main system piping with the same size pipe as the tank connection; the pipe shall not be necked down to a smaller size.
 - c. There shall be provisions in the piping connecting the hydro-pneumatic tank to main system piping that will allow the tank to be isolated from the system and drained of water while isolated.
 6. All packages shall come factory equipped with a low-suction pressure safety and a way to communicate with the campus BAS.

6.6.5.3 Facility Potable-Water Storage Tanks

1. Internal epoxy coated tanks shall not be used.
2. If the designer chooses to use a glass-lined tank, a double glass-lined coating shall be used if available.
3. If multiple tanks are being piped together to act as a single thermal mass, the tanks shall be piped in the 'reverse-return' method so that the piping pressure drop across all tanks is equalized.

6.6.5.4 Domestic Water Heat Exchangers

1. All heat exchangers for domestic water use shall be double-wall construction.
2. All heat exchangers for domestic water use shall be constructed of material suitable for domestic hot water use. Cast iron is not permitted.
3. Steam-to-Water Heat Exchangers
 - a. All steam-fired water heaters shall be provided with 1/3 - 2/3 steam control valves.
 - b. Steam pressure serving a water heater's control valve shall not be greater than 15 psig.
 - c. Select a heat exchanger with a fouling factor that is appropriate for the application.

- d. To avoid temperature overshoot, water heaters marketed as ‘instantaneous’ type water heaters shall only be allowed for dump loads with little load modulation required. Water heaters for all other applications shall be ‘semi-instantaneous’ or ‘storage’ type.
 - e. All steam-to-water water heaters shall be provided with steam control valves. Water heater designs that do not control steam flow and rely solely on a water tempering valve for temperature control are not allowed.
4. Water-to-Water Heat Exchangers
- a. Water-to-water heat exchangers used for the primary water heater in a system shall be either brazed plate or plate and frame type; shell and tube type construction is only allowed for heat recovery/preheat applications.
 - b. Plate type heat exchangers shall be sized for a maximum pressure drop of 6 psig.
 - c. Plate and frame type heat exchangers shall be provided with enough carrier bar length to allow plate inspection and cleaning without having to remove the plates from the carrier bar.

6.6.5.5 Fuel-Fired Domestic Water Heaters

1. Propane shall only be used when natural gas is unavailable onsite and the system will be 100,000 Btu/h input or larger.
2. High-efficiency (condensing) water heaters shall be used whenever possible.
 - a. All condensing water heaters shall be provided with acid-neutralizers per the manufacturer’s instructions.
 - b. Venting for condensing water heaters shall be sloped back to the water heater (minimum 1/8" per foot). If vent routing will not allow the whole vent to be sloped back to water heater, a tee with pigtail drain connection and separate acid neutralizer shall be installed at a point so that all vent can be sloped back to the water heater or the pigtail drain.
3. When multiple water heaters are located in a single space, individual vents shall be used in lieu of common venting.
4. Water heaters shall be vented per the manufacturer’s instructions using only the venting material(s) approved by the manufacturer.
 - a. PVC is not an acceptable venting material and will not be allowed, even if the manufacturer has approved it for use.

- b. Because of its higher maximum temperature ratings, chlorinated polyvinyl chloride (CPVC) is an acceptable venting material.
- 5. All water heaters shall have some means of communicating with the BAS. At a minimum, water heaters shall be able to communicate status and alarm.
- 6. All gas-fired appliances shall have individual gas pressure regulators.
- 7. Gas pipe serving water heaters shall be sized per the Fuel/Gas Code as well as the manufacturer's installation instructions.
 - a. The gas pipe system shall be designed to supply gas to the water heater at a pressure that is within the equipment's operating range.
 - b. If the water heater has a modulating gas valve, the supply gas pipe shall also be designed so that the gas pressure fluctuates only within the manufacturer's specified limits when operated between low and high fire.

6.6.5.6 Instantaneous, Tankless, Gas Domestic Water Heaters

- 1. Instantaneous water heaters shall be designed for commercial use; use of a residential product is prohibited.
- 2. Minimum heat exchanger warranty shall be 5 years.

6.6.5.7 Electric Domestic Water Heaters

- 1. In general, electric domestic water heaters shall only be used if steam, natural gas or propane is not available.
- 2. Acceptable applications for electric water heaters are:
 - a. Small point-of-use (under sink) applications.
 - b. Booster heater applications.
 - c. Small systems (50 gallons or less storage).

6.6.5.8 Drinking Fountains

- 1. Specify wall or surface mounted, fully accessible drinking fountains in corridors; exact locations to be determined during design. Each fountain shall have its own compressor. Water shall not be cooled at another location.
- 2. A bottle filling attachment shall be provided at all drinking fountain locations. Locate a single bottle filling unit on each floor and a double unit on the main floor for ADA compliance.

6.6.6 Materials and Systems

6.6.6.1 Steam and Condensate Piping and Pumps

1. All valves and steam devices used on steam lines utilizing the campus steam utility shall be rated for minimum 500 °F and 1.5 times the working pressure.
2. Metering – See DCSM section 5.1.1 for energy efficiency guidelines.

6.6.6.2 Steam and Condensate Piping Specialties

1. Steam Traps:
 - a. Steam Traps on all HVAC equipment shall be ¾" or larger and sized for the load times 1.5 or more depending on use.
 - b. All steam traps must be gravity drain. All must have sloped drains no level or up sloped piping.
 - c. All steam traps shall be listed on a schedule by number, pipe size, load in pounds per hour, equipment served, type, max pressure and differential pressure.
 - d. Exceptions: Drip legs on steam mains may be piped up but not for long runs and they should be gravity flow for start-up if on the end of a line that may collect condensation.
2. Discharge of high pressure steam condensate into low pressure steam or low pressure condensate is prohibited. High pressure condensate will be flashed into a tank vented to the outside preferably to the roof.
3. Bronze and brass valves shall not be used on steam and condensate piping and equipment.
4. All steam or condensate fittings, valves and other equipment shall be 150 lb. flange or greater. No 125 lb. fittings.
5. Steam relief valves shall be piped to the roof without other equipment connections to the line.
6. High pressure flash tanks shall be vented to the outside without reducing the outlet pipe size. None shall be connected to low pressure steam.
7. Steam relief valves and drip-pan ells shall not be reduced but run full size to the roof.
8. Steam and condensate piping shall not be run outside or in unheated spaces.
9. Pumped steam condensate shall not be mixed with gravity flow condensate.
10. Do not install bypass lines on steam reducing stations nor steam traps.

11. Flange gaskets on high pressure steam shall be metal reinforced and bolts grade 8.
12. Direct steam heating systems shall be designed for low pressure operation. Typically, coils and heating equipment shall be selected at 5 psi steam pressure to meet required heating capacity. They system shall be designed for operation at 10 psi with relief set at 15 psi. These design conditions apply whether the steam source is the campus low pressure (nominal 15 psi) or the high pressure (nominal 90 psi) distribution system.

6.6.6.3 Pressure Powered Steam Condensate Pumps

1. Preference is given to pressure powered steam condensate pumps over electric.
2. Pressure powered pumps will be used if it is determined that the high pressure steam will provide enough discharge pressure to return condensate to Power Plant or pumping station. Care must be taken to insure all condensate will gravity flow into the tank.
3. Steam condensate return lines that have more than one steam trap connected to them shall be 1.5 inches or larger.

6.6.7 Storm, Sanitary, and Chemical Waste Systems

6.6.7.1 Facility Sanitary Sewerage

1. Extra heavy cast iron hub piping shall be used on all sanitary and storm sewer drains that are located under concrete floor slabs or under other inaccessible floor construction.
2. The use of PVC piping in under-floor slabs is prohibited.
3. All piping shall be a minimum of 3 inches below top of slab.

6.6.7.2 Sanitary Waste Piping Specialties

1. All mechanical rooms shall have a minimum of two floor drains per mechanical room.
 - a. Floor drains for mechanical rooms shall have a minimum 4-inch inlet connection.
 - b. All floor drains in mechanical rooms shall be piped in cast iron. Plastic pipe is prohibited.
2. All sanitary mains under slab shall be video-scoped to verify there is no standing water. This inspection shall happen after the slabs are poured and prior to the issue of a Change Order.

3. All restrooms shall have floor drains, centrally located with floor slightly sloped toward drain.
4. Acid resistant lines shall be used from laboratories to a point where waste water should dilute an accidental or unintentional acid release into the wastewater system.

6.6.7.3 Sanitary Sewerage Pumps

1. Any sanitary sump pump that is expected to have solid waste shall be designed to pass a minimum 2-inch sphere.
2. All sanitary sewerage pumps shall be provided as a duplex set with each pump sized for 100% of design.

6.6.7.3.1 Submersible Sewerage Pumps

1. Any submersible sump pump that is used for sanitary waste shall be provided with explosion proof motors and intrinsically-safe controls.
2. All submersible sewerage pumps shall be provided with removal rail systems.

6.6.7.3.2 Sewerage Pump Basins and Pits

1. Follow pump manufacturer's recommendations for minimum sump water level, to ensure proper cooling of the pumps.
2. The pump basin depth should be sized to allow a minimum pump run-time of 90 seconds, and to have enough space for all floats below the invert.

6.6.7.4 Facility Storm Drainage – Sump Pumps

Any submersible storm pump that serves a parking structure or any other location where flammable liquids can be introduced into the drainage shall be provided with an explosion proof motor and intrinsically-safe controls. All stormwater sump pumps shall be duplex.

6.6.7.5 Rainwater Reclamation Systems

1. Reclaimed rainwater will not be used in fixtures within a building without the approval of Engineering Operations.
2. If a rainwater reclamation system is to be used, some form of disinfection (UV, chemical injection, etc.) must be used in conjunction with filtration prior to supplying the reclaimed water to fixtures.
3. Any rainwater reclamation system shall have an integrated municipal water backup with a backflow preventer.
4. All piping shall be labeled.

6.6.7.5.1 Facility Stormwater Retention Tanks for Rainwater Harvesting

See the VTAS&S for requirements.

6.6.7.6 Commercial Water Closets

Water closets shall be elongated vitreous china, wall hung, siphon jet, flush valve and trim for 1.28 gallons per flush (GPF), seat chair carrier, and chromium-plated nuts and washers.

1. Allowable manufacturers and models for regular use are:
 - a. American Standard 2237.001
 - b. Kohler K-4325
 - c. Sloan ST-2059-A
 - d. Toto CT708E
2. Allowable manufacturers and models for ADA use are:
 - a. American Standard 3351.001
 - b. Kohler K-4325
 - c. Sloan ST-2059-A
 - d. Toto CT708E

6.6.7.7 Commercial Urinals

1. Urinals shall be top spud water saver wash down type designed to flush between 0.5 and 1.0 GPF or less. The basis of design shall be Toto UT 104 or equal.
2. Waterless urinals shall not be used.

6.6.7.8 Commercial Sinks

1. Service Sink shall be floor mounted, precast concrete or stone construction located at an 8-inch maximum height from floor to rim, 24" × 24" (minimum size).
2. Faucet-vacuum breaker, integral stops, spout with pail hook and nose end, top single brace, renewable units and valve seats; the basis of design shall be equal to Elger 749-1200 or 749-1400.

6.6.7.9 Commercial Showers

Install pressure compensating water saving shower heads on all showers at set at 2 GPM. Shower heads at less than 2 GPM must be approved by Facilities for functionality before installation.

6.6.7.10 Commercial Faucets, Supplies, and Trim

1. All faucets shall be fitted with 0.5 GPM pressure compensating flow controls.
2. Touchless faucets shall be installed on at least one sink in each restroom for accessibility where possible.
 - a. The basis of design for touchless faucets shall be Toto Eco-Power Auto Sink Sensor (or equal) that utilizes a hydro-powered turbine to charge the power supply and extend the battery life.
 - b. Battery warranty for touchless faucets shall be a minimum of 10 years.
3. Sensor type touchless automatic faucets shall not be installed in buildings for which the domestic hot water source is the central loop from the Power Plant due to large pressure variations. Two-handled faucets shall be installed where touchless faucets cannot be used. Faucets shall be two-handled lever type on at least one lavatory for accessibility.
4. Install touchless faucets on all lavatories in restrooms in new building projects and capital renovations in minimum quantities on renovation projects as follows (note at least one of the touchless fixtures shall be ADA accessible):
 - a. On 1 lavatory in restrooms with 1 to 3 lavatories.
 - b. On 2 lavatories in restrooms with 4 to 6 lavatories.
 - c. On 3 lavatories in restrooms with 7 to 10 lavatories.
5. Sensor type faucets shall include the thermostatic mixing valve in the faucet control box. A single source faucet shall only be specified if pre-tempered water is provided to the unit. The thermostatic mixing valve shall be pressure compensated to adjust for different pressures in the hot and cold water lines.

6.6.7.11 Flush Valves and Flushometers

1. Water closet and urinal flush valves or flushometers shall be exposed, mounted on the fixture in the restroom, not in a chase. Manual piston type (not diaphragm type) mounted on water closets (1.6 GPF or 1.28 GPF) and urinals (1.0 GPF or 0.5 GPF). Valves should be adjustable to allow for slight increases or decreases in flow. The basis of design shall be Toto urinals or water closets as listed below.
 - a. Toto TMU1NNC-12 or TMU1LN 12#CP Manual Urinals.
 - b. TEV1GNC-12 or TEV 1 LN 12#CP Automatic Urinals.

- c. Water Closet Manual TMT1NNC-32 or TMT1LN#CP or Automatic TETGNC-32 or TET1LN-32#CP.
- 2. Sensor operated automatic flush valves with manual override button. The basis of design for auto-flush, touchless valves shall be Toto Eco-Power Sensor Valve (or equal) battery powered device that utilizes a hydro-powered turbine to charge the power supply to extend battery life up to ten years.
- 3. Install the auto-flush, touchless valves on all water closets and urinals in new building projects and in minimum quantities on capital renovation projects as follows:
 - a. On all accessible water closets.
 - b. On 1 water closet and 1 urinal each in restrooms with 1 to 3 fixtures.
 - c. On 2 water closets and 2 urinals each in restrooms with 4 to 6 fixtures.
 - d. On 3 water closets and 3 urinals each in restrooms with 7 to 10 fixtures.

6.6.7.12 Laboratory Chemical-Waste and Vent Piping

Separate acid-resistant sanitary systems shall not be provided for laboratory operations, nor shall an acid neutralization system be provided.

6.6.8 Piping Systems for Gases

6.6.8.1 General Service Compressed Air Systems

- 1. Provide all air compressors with mufflers.
- 2. Buildings that require laboratory air shall have a dedicated air compressor with redundancy and auto blowdown.

6.6.9 Emergency Shower and Eyewash Equipment

- 1. A floor drain is required in all spaces that have safety showers in new buildings.
- 2. Each shower and eyewash station shall have an isolation valve for service.

6.7 HEATING, VENTILATION, AND AIR CONDITIONING

Provide bound, indexed O&M manuals. Manuals shall be organized by systems and fully indexed by equipment type. Must contain original manufacturer's bulletins and manuals, copies are not acceptable.

6.7.1 Common Work Results for HVAC

- 1. Blacksburg Campus Design Conditions: Indoor design conditions shall conform to current energy code. Winter outdoor design temperature shall

- be -10 °F; that is all mechanical equipment shall be able to operate and provide the building heat at -10 °F without tripping on freeze stat. Design altitude shall be 2150 feet for all design calculations.
2. All capitol renovations and new construction shall utilize central steam, condensate and chilled water utilities when available.
 3. Mechanical designer shall lay out zones with a reset schedule in mind. All perimeter heating in capital projects must be zoned.
 - a. Renovation projects shall not remove existing perimeter heat without approval from Engineering Operations.
 4. Provide standby or redundant equipment, cycled or alternating lead-lag sequence for critical needs (e.g., standby compressors on refrigeration for food storage).
 5. Use dual independent refrigeration circuits on HVAC equipment where available, particularly when serving critical areas such as IT closets, animal holding/vivariums or other critical research.
 - a. Areas that house critical research and are temperature sensitive must have dedicated independent mechanical systems. The central chilled water utility and building HVAC infrastructure are all interruptible utilities and cannot be relied on for critical research. Campus and/or building systems can be used as a back up to the dedicated primary systems.
 6. Provide access doors for all maintenance items above inaccessible ceilings and into inaccessible walls. If necessary, fire rated access doors shall be used to preserve wall fire rating.
 7. All buildings shall contain storage space for a minimum of one complete change of air filters for all HVAC equipment. The storage space shall be dry and (preferably) accessible from the loading dock or service entrance.
 8. Accessible doors to crawl spaces shall be located as close as possible to mechanical equipment under floor.
 9. Locate filter boxes and other maintainable equipment outside of critical areas served, such as operating rooms, so that items can be serviced without disrupting operations in the room or releasing contaminants into space.
 10. Locate humidifiers, fan coil units, terminal boxes, and other equipment containing water over hallways rather than occupied or critical spaces wherever possible.
 11. Provide adequate roof access (stairs or elevator) wherever serviceable equipment is roof mounted. Ladders to roof hatches are not acceptable. If there is a penthouse in a building, one of the elevators must go to it.

12. In atriums or other multi-story open to roof areas, maintenance and accessibility shall be a consideration when mounting fans, lights and other equipment above the floor.
13. Primary manufacturer/model number to be specified for various types of mechanical equipment is specified herein. Provide a minimum of two additional and equivalent valve manufacturers and model numbers for each primary manufacturer and model number listed.
14. Mechanical System Designer shall list building design loads and the installed equipment capacities for heating, ventilation, cooling and domestic hot water on the first mechanical drawing.
15. Process cooling requirements shall be addressed by a dedicated process cooling system. Process cooling shall not be achieved using the building chilled water system, the campus chilled water system or the building domestic water system. Process cooling is defined as anything other than “comfort cooling” (including all water cooled condensers).
16. Any new 100% outside air system shall include a heat pipe or heat wheel for heat recovery, or other approved heat recovery method.
17. Mechanical Rooms and Equipment Locations:
The A/E shall, in the earliest stages of design development, be responsible for establishing and/or verifying programmatic requirements for mechanical rooms in order to:
 - a. Provide adequate safe access and manufacturer’s recommended working clearances for all equipment.
 - b. Provide for replacement of the largest piece of equipment without removing permanent walls or roof, large items of equipment, or equipment essential to the principal on-going day-to-day building use.
 - c. A minimum of one mechanical room per building must have direct access to the outdoors. The minimum door size is a standard 3' × 7' door with walk in access.
 - d. In phased projects mechanical rooms shall be sized to include equipment for all the phases.
 - e. Air handling units, zone control devices, such as VAV boxes, mixing boxes, reheat coils, etc., shall also be located to provide unobstructed access to filters, manual valves, zone control devices and automatic control equipment.
 - f. Mechanical rooms shall have a floor drain.
 - g. Access to ducted fan coil units on occupied floors shall be from corridors, rather than through offices, classrooms, laboratory ceilings, or other occupied spaces.

- h. The installation of air handling equipment above the ceiling with cooling coils shall have a water level detection device (UL 508) that will shut off the chilled water valve (but leave the unit fan operating) if drain is blocked. The device shall be in the primary drain pan on the equipment or the overflow line in the primary drain pan. An auxiliary drain pan shall not be installed.
 - i. Equipment mounting stands shall be constructed of steel. Wood stands are not acceptable.
 - j. Dashed or faded outlines shall be provided for all mechanical equipment on drawings. Provide notes as required to indicate clearances for maintenance, installation, or provisions for servicing. Coordinate with electrical drawings.
18. Ventilation: Outside air intakes shall not draw in exhaust air from adjacent systems, loading docks, parking lots, emergency generators, chemical storage, sewer manholes, etc.
19. Air Conditioning
- a. If available, campus chilled water utility shall be used as the cooling medium for all new buildings on campus. If the central chilled water utility is not available, the building shall be designed to cool with a central chilled water system.
 - b. For projects in an existing building, if sufficient capacity is available in an existing chilled water system, chilled water shall be used as the cooling medium for any new or renovated spaces.
 - c. Direct Exchange (DX) systems shall not be used except for in small non-occupied computer server rooms or after specific approval by the University. On DX systems, total refrigerant charge shall be listed on the unit.
 - i. Exceptions: DX systems shall be used for server rooms, CNS closets, electrical rooms or critical research spaces. Consider installing a backup cooling-only VAV in critical applications.
 - d. Glycols and other heat transfer fluids shall only be used in limited systems such as heat recovery loops, or thermal storage systems which serve only a single central station AHU. Use only after specific approval by the University.
 - i. Use only propylene glycol. 33% mixture is the preferred solution on campus. All glycol systems shall have a glycol makeup system.
 - e. Water-cooled condensing units using domestic, potable water on a single-pass cycle are prohibited.

20. Cooling Coil Condensate
 - a. Cooling coil condensate shall be piped to sanitary drains.
 - b. The use of pumped condensate systems shall be minimized.
 - c. Cooling coil condensate lines shall have cleanouts which allow access of all branches of the condensate drain system.
 - d. Cooling coil condensate lines shall be minimum 1¼" ID.
 - e. Lines less than 1½" shall be copper instead of PVC.
21. Provide adequate freeze proofing for all air handling equipment with high percentage of outside air. Provide coils that can be drained.
22. Transferred return air for ventilation (second hand ventilation air) is unacceptable. Transfer ducts are not allowed.
23. Overall building pressure shall be 0.03-0.05" W.C. positive in relation to the outside under occupied, unoccupied and standby modes.
24. The use of line-voltage thermostats in any occupied or residential space is prohibited. Line voltage thermostats can be used in areas such as mechanical, electrical and storage rooms as long as the voltage is 120 V or less.

6.7.2 Selective Demolition for HVAC

Keep air handling equipment clean during construction.

1. If equipment is going to be operated during construction, change filters once a month or more often if needed and install filter media over return grilles.
2. Keep fan coil units clean by covering inlet and outlet during construction when not in use.
3. Building must be turned over to the University upon project completion with clean air handling equipment and duct systems; including a clean set of air filters installed in the air handling equipment and with a quantity of filters for one additional change left in the building.

6.7.3 Common Motor Requirements for HVAC Equipment

1. All VFD controlled motors shall have grounding rings with a life expectancy of 200,000 hours. The basis of design for grounding rings shall be AEGIS.
2. All VFDs shall be accessible from the outside of equipment (i.e., not inside of an air handler).
3. Max speed for motors on VFDs shall be 60 Hz (including fans and pumps).
4. All VFDs shall have a line voltage bypass that does not rely on any electronic controls within the VFD but all safeties for air handlers or pumps shall be in the circuit (e.g., freeze stats).

5. One VFD per motor. Multiple motors on a single VFD are prohibited.
6. If there is a standby fan or pump (N-1), a VFD bypass is not necessary. If a fan array is used with a VFD for each fan, a bypass is not necessary.
7. ECM motors shall not be used on campus.
8. Outdoor mounted VFD are not preferred and should be avoided when possible. Use a 3R enclosure if installed outside.
9. Equipment with remote mounted VFDs shall have signage indicating that the starter must be turned off and indicate the location of the starter.

6.7.4 Expansion Fittings and Loops for HVAC Piping

Expansion hard loops of pipe are the preferred method of controlling expansion. Other methods must be approved by Virginia Tech Facilities.

6.7.5 Sleeves and Sleeve Seals for HVAC Piping

Seals between the exterior and interior of the building shall use a “mega seal” type sealant to prevent the infiltration of water.

6.7.6 Meters and Gauges (Inside the Building)

1. Provide differential pressure indicator (manometer) for all serviceable filters and locate the indicator where it can be readily observed. Mark on the indicator the “clean” and “replace filter” points.
2. Gauges are required for:
 - a. Differential pressure on pumps.
 - b. Solar digital thermometers on the inlet and outlet of all heat exchangers, boilers and chillers.
 - c. Pressure gauges on the condensate return line leaving the building to the utility tunnel.
3. See DCSM section 5.1.1 and DCSM 4.7 for energy metering and utility tunnel metering and gauging requirements.

6.7.7 General Duty Valves for HVAC Piping

6.7.7.1 General Valve Standards

1. Valves 2½" and smaller shall be provided with lock handles.
2. Valves 3" and larger shall have manual hand wheel worm gear.
3. Ball valves shall be Class 150 full port threaded or flanged.
4. Any point that the piping of supply and return water is connected on chilled water or heating water there shall be hand valves to isolate each. Control valves shall not be used for isolation.

5. Valves on chill water lines shall have extended handles for proper operation without damage to pipe insulation.
6. Gate and control valves with stems shall be installed with stems straight up but never lower than 90 degrees.
7. Valves with non-rising stems shall have tags to show open or closed.
8. Provide sufficient air vents at high points in chilled and hot water piping systems to easily bleed entrapped air.
9. Steam valves shall be forged or cast steel body and rated for a minimum of 500 °F super-heated steam.
10. Gate valves of 150 or 300 Class, flanged over 2 inches.
11. Cast or forged steel body ball valves may be used for steam condensate and rated for temperature and twice the pressure but only 2" and below in size.
12. Ball or gate valves with steel bodies should be used on steam and condensate gauges with the proper temperature and pressure rating.
13. No sweat valves of any type shall be used. Control valves, strainers, check valves, or balance valves.
14. Use appropriate gasket materials for flange connection.
15. No bronze or brass valves on steam. See DCSM section 6.6.6.2.

6.7.7.2 High Performance Butterfly Valve Standards, 2½" and Larger

1. High Performance Butterfly Valves shall be double offset design in accordance with ASME Class 150, 300 or 600, as required and MSS-SP68 "face-to-face".
2. Full lug end pattern.
3. Double Dead-End bi-directional zero leakage must exceed ANSI Class IV leakage standard.
4. Only High Performance Butterfly Valves or High Performance Triple Offset Butterfly Valves shall be used on steam or critical shut off connections.
5. Valves shall meet ANSI B16.34, B16.10, and B16.5 Flange Drilling: MSS-SP68 "face-to-face"; API 609 latest version for blow-out proof stem retention.
6. Valves shall be full lug with extended neck to accommodate 2" of insulation.
7. Valves must provide "Double Dead End", bi-directional service with down-stream flange removed at full-rated Cold Working Pressure (ASME Cl. 150 = 285 psig).

8. HPBV to be used on steam to 150 psig. Use triple offset on steam above 150 psig.
9. The seat shall be designed to be bubble tight, bi-directional at 0 psi, high pressure, and under vacuum.
10. Valve identification plate to be permanently attached in accordance with MSS-SP25 and ASME B16.34.
11. Materials of construction and design shall be:
 - a. Body: ASTM A-216, Gr. WCB, Carbon Steel or Stainless Steel
 - b. Disc: ASTM A351, Gr. CF8M, Type 316 SS
 - c. Stem: ASTM A564 Type 630, 17-4 PH SS
 - d. Disc Pins: ASTM A564 Type 630, 17-4 PH SS
 - e. Seat: RPTFE self-adjusting for both high and low pressure service
 - f. Stem Bearings: 316 SS Glass/Teflon lined or 316 SS/BRZ/PTFE
 - g. Packing: PTFE adjustable with carbon fiber ring to provide constant compression and seal for full rating of valve or Stainless Steel rings.
12. Performance and Testing:
 - a. Valves shall meet API 598, and be bubble tight, bi-directional at 0 psi, high pressure, and under vacuum. Valves are to be zero leakage, bi-directional shut off.
 - b. Each valve to be tested to 110% of cold working pressure rating, ANSI 150 = 315 psig, zero leakage allowable.
13. Accessories:
 - a. Valves 2" to 2.5" shall be provided with 10 position latch lock handle with OSHA "Lock out/Tag Out" feature.
 - b. Valves 3" and larger shall be provided with hand wheel manual weatherproof worm gear actuators with SS input shaft.
 - c. All valves 7 feet from the floor shall be furnished with chain-wheel worm gear actuators, weather proof with security cable device.
 - d. All valves shall be capable of automating without removing the valve from the line and without the use of brackets and actuator to valve shaft couplings.
14. Installation:
 - a. Use appropriate gasket materials for flange connection.
 - b. Install with retaining plate upstream, normal flow.
 - c. Follow manufacturer's recommended bolt chart.
 - d. Valve may be installed with valve shaft vertical or horizontal.
 - e. Install in accordance with manufacturer's Installation Manual.

6.7.7.3 Resilient Seated Butterfly Valve Standards, 2" to 20"

1. These can be used in standard specifications for all applications in condenser water, chilled and hot water (excluding steam and condensate) and glycol/water solutions for shut-off. Do not use if water temperature is 200 °F or more.
2. Manual Butterfly Valves shall be of the "resilient seated" design rated for 230 psig shut-off bi-directional dead end service with downstream flange removed. Valves shall be full lug, compatible with ANSI 125/150 flanges. Valves shall be designed in accordance with MSS-SP 67; ISO 5752. Valve design shall accommodate 2" of insulation.
3. Valves 3" and smaller shall be provided with 10-position lever lock handles. Valves 4" and larger shall be provided with hand wheel manual weatherproof worm gear actuators. All valves located more than 7 feet from the floor shall be furnished with chain wheel weatherproof worm gear actuators with security cable device.
4. The basis of design for valves shall be Bray Series 31H-119 or Keystone 222/GR or University approved equal.
5. Performance and Testing: Valves shall be individually tested at the factory to 110% of rated pressure with zero leakage.
6. Materials of construction and design shall be:
 - a. Body: Cast Iron, Ductile Iron, Stainless Steel or Carbon Steel
 - b. Disc: Nylon 11, 15 mil thick and thermally applied over Ductile Iron ASTM 536 Grade 65-45-12 or 316 SS. Epoxy coated, Nickel plated, or Aluminum Bronze discs are not acceptable.
 - c. Stem: Type 300 or 400 series Stainless Steel, one piece, and shall utilize an internal connection to the disc via a double "D" or splined drive; or stub shaft designs with Hexagonal disc/stem connection.
 - d. Seat: EPDM
 - e. Packing: Buna-N with acetyl bushing; or polyester bushing.
7. Installation:
 - a. Do not use gaskets.
 - b. Follow manufacturer's installation instructions and bolt charts.
 - c. Valves may be installed with stem vertical or horizontal.
 - d. Do not use on steam.

6.7.8 Heat Tracing for HVAC Piping

1. Provide electric heat trace for any fluid system without glycol that has the potential to freeze.

2. Provide all heat trace with a controller with dry contacts that can alarm to DDC.
3. Care needs to be taken on flanges, valves and gauges that are heat traced. Follow manufacturer's recommendation for installation.

6.7.9 Vibration and Noise Controls for HVAC

1. Vibration Controls
 - a. Special attention shall be paid for sensitive areas such as penthouses and low noise criteria spaces.
 - b. All hanging equipment shall be provided with vibration isolation unless there is internal fan isolation in the unit.
2. Noise Control: Use duct silencers for noise control. Interior duct liners are not acceptable.

6.7.10 Identification for HVAC Piping and Equipment

1. Use laminated plastic stick-on tags to identify equipment. Use wrap-around labels or stencil to identify piping.
2. Tag all mechanical equipment to match the records documents.
3. Mark location of air handlers, fan coil units, mixing boxes, etc., above ceilings with identifying buttons to facilitate maintenance through ceiling.
4. Tag roof top exhaust fans and associated fume hood to facilitate maintenance and identification.
5. Utilize standard tag or placard to mark all major equipment. Tag all valves and provide valve chart for each floor.
6. Mark each with name of service, direction of flow, and associated unit served where appropriate.
7. All systems handling hazardous materials must have appropriate marking and visual or audible alarms to protect building occupants and maintenance personnel.
8. Mark air handling units with large letters and numbers.
9. All fire dampers shall be numbered and identified on chart in mechanical room. Provide damper location drawing to facilitate future testing.

6.7.11 Anti-Microbial Coatings for HVAC Ducts and Equipment

1. All interior surfaces of air handlers shall be coated with anti-microbial paint except fins on coils, dampers, fan wheels, and stainless steel components like humidifiers. This should be done at factory and not on site.

2. All interior surfaces of outside air, and the first 15' of supply and return air ducts including dampers, turning vanes and extractors shall be treated with an anti-microbial substance.
3. Acceptable anti-microbial treatments for interior surfaces of ductwork and equipment shall be as indicated below (approved proposed equals will be considered but must be specifically approved by the University):
 - a. Fosters40-20™
 - b. AgION anti-microbial compound treatment for metal duct and equipment, blue coating. Process as provided by Lindab, Inc.
 - c. Avron 46 anti-microbial coating by Semco, Inc
4. The application of anti-microbial paint to the interior surfaces of air handling units, fan coil units, VAV boxes and other terminal boxes shall be done at the factory. Field coating of these surfaces is not acceptable. Interior coating of ductwork can either be field or factory applied.

6.7.12 Testing, Adjusting, and Balancing for HVAC

1. The final Testing, Adjusting, and Balancing (TAB) report shall include building pressurization readings taken at all exterior doors. The system shall be in automatic mode for cooling and heating.
2. A/E to recommend pre-TAB for renovations utilizing existing equipment.
3. The A/E shall develop a balance and testing procedure for exhaust and make up air for entire building and each device in the system (snorkels and hoods) so the same procedure and equipment is used on both balancing and functional testing for commissioning. Any special devices needed for balancing shall be furnished by the manufacturer and given to the University after completion of the project.
4. Balancing of HVAC system should be done with clean filters in air handling units to be checked by balancing firm and stated in report.
5. Verification of face velocity on air handlers and chill water coils 450 FPM or less are not to exceed design.
6. Verification of condensate traps on chill water coils operation at 101% of air handler speed.
7. All adjustable sheaves shall be replaced with fixed after correct fan speed is determined and noted in balance report.

6.7.13 Schedules for HVAC

1. Provide schedules of all fire dampers and access locations.
2. Schedule VAV tag numbers to reference both floor location and air handler number it is served by. Example: Floor # - AHU# - VAV Box #.

3. Update all schedules to reflect the actual installed equipment for records drawings.

6.7.14 Duct Insulation

1. Use ridge exterior duct insulation on exposed areas. Can be reflective in mechanical spaces but paintable in public areas.
2. All outside air ducts and supply ducts shall be insulated inside the building and return ducts shall be insulated where they may have heat lost due to temperature differences or condensate.
3. No interior duct insulation (liner) shall be used. Duct insulation shall be by use of any of the following:
 - a. Exterior duct wrap.
 - b. Factory fabricated double wall metal duct with solid metal inner wall with insulation between walls.
 - c. Factory fabricated double wall metal duct with perforated metal inner wall with insulation between walls and 3 mils thick Mylar between inner liner and insulation. (Use this method only where noise is of particular concern.)

6.7.15 HVAC Equipment Insulation

Double wall construction shall be specified for Air Handling Units, Fan Coil Units, Variable Air Volume Boxes, or other Terminal Boxes. Insulation shall be between the inner and outer walls. The inner wall shall be solid metal (not perforated) so that no insulation is exposed to the air stream.

6.7.16 HVAC Piping Insulation

1. The basis of design for pipe insulation on piping with an operating temperature of 42 °F to 60 °F shall be FOAMGLAS® or equal (1.5") thick on pipe sizes 2" through 4" and 2" thick or more to prevent condensation at 95% relative humidity in unconditioned spaces on sizes over 4". The engineer shall determine thickness and type of insulation. Rubberized or Ameriflex type insulation is not to be used on sizes over 2" pipe. Engineer will be responsible for determining the cause and correction of condensation on chilled water piping if it occurs.
2. All piping operating under 80 °F shall be insulated (i.e., chill beams).

6.7.17 Instrumentation and Control for HVAC

See DCSM section 6.3 for BAS design standards.

6.7.18 Hydronic Piping Specialties

1. Isolation/shut-off valves shall be provided on piping entering and leaving (supply and return) all HVAC equipment (air handling units, fan coil units, VAV boxes and pumps).
2. Triple duty valves shall not be used. Pumps shall be controlled by , or a dedicated balancing valve with a separate isolation valve and check valve.
3. All hydronic control valves shall be selected with a minimum close off pressure capacity of 45-50 psig. All valves must be able to close against system pressure.
4. All equipment used on hydronic system shall be capable of operating correctly with pressures and flows that they system develops. Valves shall open and close fully and not make noise, cause water hammer or cavitation.
5. Control valves shall be sized for flow, not selected by line-size.

6.7.19 Hydronic Pumps

1. Provide parallel stand-by pump for all primary pumped building systems (chilled water, heating, and domestic hot water, etc.).
2. Preferred pump construction is base mount, split couple.
3. 1750 RPM is the preferred pump speed selection. 1150 RPM pump selections should not be used.
4. Provide start-up alignment for all split-couple pumps after installation.
5. Dual suction pumps shall be considered for any flow rates over 1000 GPM.
6. Pump model and horsepower shall be selected by the scheduled duty point. If the pump will be on a drive, provide the pump with the largest, non-overloading impeller trim for the selected horsepower rating.
7. In-line pumps shall be 7.5 hp and below.

6.7.20 Automatic Condensate Pump Units

If possible, provide cooling condensate units that can allow DDC interface.

6.7.21 Steam and Condensate Piping and Pumps

6.7.21.1 Steam and Condensate Heating Piping

1. All valves and steam devices used on steam lines shall be rated for minimum 500 °F and 1.5 times the working pressure.
2. Pitch all condensate a minimum of ¼" per foot towards a drain point.
3. Steam metering – See DCSM section 5.1.1 for energy efficiency guidelines.

6.7.21.2 Steam and Condensate Heating Piping Specialties

1. Steam Traps:
 - a. Steam Traps on all HVAC equipment shall be $\frac{3}{4}$ " or larger sized for the load plus a minimum safety factor of 1.5 or more depending on use.
 - b. Drain lines that carry chill water condensate from two or more units shall be minimum 1.25" in diameter.
 - c. All steam traps must be gravity drain. All must have sloped drains no level or up sloped piping.
 - d. All steam traps shall be listed on a schedule by number, pipe size, load in pounds per hour, equipment served, type, max pressure and differential pressure.
 - e. Use float and thermostatic trap type steam traps for all modulating equipment.
 - f. If steam trap selection is larger than a 2" inlet connection, provide two parallel steam traps in lieu of one large steam trap.
 - g. Exceptions: Drip legs on steam mains may be piped up but not for long runs and they should be gravity flow for start-up if on the end of a line that may collect condensation.
2. Discharge of high pressure steam condensate into low pressure steam or low pressure condensate is prohibited. High pressure condensate will be flashed into a tank vented to the outside preferably to the roof.
3. Bronze and brass valves shall not be used on steam and condensate piping and equipment.
4. All steam or condensate fittings, valves and other equipment shall be 150 lb. flange or greater. No 125 lb. fittings.
5. Steam relief valves shall be piped to the roof without other equipment connections to the line.
6. High pressure flash tanks shall be vented to the outside without reducing the outlet pipe size. None shall be connected to low pressure steam.
7. Steam relief valves and drip-pan ells shall not be reduced but run full size to the roof.
8. Steam and condensate piping shall not be run outside or in unheated spaces.
9. Pumped steam condensate shall not be mixed with gravity flow condensate.
10. Do not install bypass lines on steam reducing stations nor steam traps.
11. Flange gaskets on high pressure steam shall be metal reinforced and bolts grade 8.

12. Direct steam heating systems shall be designed for low pressure operation. Typically, coils and heating equipment shall be selected at 5 psi steam pressure to meet required heating capacity. They system shall be designed for operation at 10 psi with relief set at 15 psi. These design conditions apply whether the steam source is the campus low pressure (nominal 15 psi) or the high pressure (nominal 90 psi) distribution system.

6.7.21.3 Steam Condensate Pumps

1. Preference is given to pressure powered steam condensate pumps over electric.
2. Pressured powered pumps will be used if it is determined that the high pressure steam will provide enough discharge pressure to return condensate to Power Plant or pumping station. Care must be taken to insure all condensate will gravity flow into the tank.
3. Steam condensate return lines that have more than one steam trap connected to them shall be 1.5" or larger.

6.7.22 Refrigerant Piping

1. Installations shall be complete with dryers, sight glasses, thermostatic expansion valves, and thermostatically controlled solenoid valves for pump-down operation (except for capillary tube units).
2. Suction lines shall be insulated. The need for defrosting is not limited to electrical units. In larger installations, hot gas defrost is required.
3. Installation shall be provided with necessary protective devices, including, but not limited to, electrical overload devices, low suction-pressure cutouts, oil traps, crankcase heaters, anti-cycling timers and head pressure control.
4. Main piping fittings for dryers, sight glasses, expansion valves and controls shall be flared.
5. A nitrogen purge shall be maintained while soldering all joints.
6. Copper-to-copper joints shall be evacuated to 29.5 inches (water) gauge vacuum and held for at least 24 hours under this vacuum prior to charging the system with refrigerant.
7. Design relief piping as necessary to comply with code requirements.

6.7.23 Refrigerants

All refrigerant types used on campus shall be approved by VT Engineering Operations.

6.7.24 HVAC Water Chemical Treatment

1. The Contractor shall notify the VT PM when and what chemicals are used to clean the piping systems and HVAC equipment. The Contractor shall furnish in writing or a form that states who installed the chemicals and removed them from the system and when it was started and finished.
2. VT Facilities maintains a water treatment contract for the campus chilled water loop. Any project that has additions or alterations to that utility shall coordinate those changes with VT Facilities.
3. After cleaning and chemically treating the HVAC system, the Contractor shall furnish to the VT PM in writing, the following information:
 - a. Date of initial treatment.
 - b. Type of chemical(s) used for treatment.
 - c. Estimated date that further treatment or testing will be required.

6.7.25 HVAC Ducts and Casings

1. Ductwork that is exposed to the weather shall be double wall, smooth inside and out, insulated, with flanged connections. Joints shall be insulated and the outside panel painted with weather resistant paint or be stainless steel exterior.
2. Where perforated inner walls are used on double wall duct, the metal perforations are not to be bridged with paint prior to assembly of double wall ducts. Painting shall not be done after assembly to prevent bridging sheet metal perforations.
3. All supply ducts with a pressure class of 2" WG or higher shall be pressure tested, documented, and results submitted to the VT PM.

6.7.26 Air Plenums and Chases

Ceiling return plenums shall not be used. All return air shall be ducted from conditioned spaces back to air handling units.

6.7.27 Air Duct Accessories

6.7.27.1 Fire Dampers

All fire dampers shall have removable ceiling tiles or access doors.

6.7.27.2 Backdraft Dampers

Backdraft dampers shall not be used for building relief.

6.7.27.3 Flexible Duct

Flexible duct may be used only for short runs of 6' or less to air outlets. Flexible duct shall be pulled tight, without any kinks, and supported with 2" wide banding to structure above to prevent any sagging. Turns and bends greater than 45 degrees shall be installed with hard round duct fittings.

6.7.28 HVAC Fans

6.7.28.1 Axial Fans for Air Handlers

1. Fans shall be direct drive, Arrangement 4, with capacities and sizes as indicated on schedules.
2. Fan blade angle shall be manually adjustable from 0 degrees to a maximum of 32 degrees.
3. Fan blades shall be 356-T6, heat treated, high strength aluminum alloy, having a true airfoil section, and having both camber and twist. Each blade shall be sized for its diameter and shall not be cut down from longer blade sections.
4. The fan hub section shall be 356-T6, heat treated.
5. The impeller shall be placed on the inlet side of the fan, before the motor. Both motor and impeller shall be removable from the inlet side of the fan.
6. Casing shall be $\frac{3}{8}$ " thick hot rolled steel. Casing and end flanges shall be welded using continuous welds by ASME, Code IX, qualified welders. Certification shall be required upon request. Guide vanes shall be welded using continuous welds to a rigid motor base and the housing.
7. The fan shall be designed so that 1/3 of the housing is removable to permit motor and impeller replacement without removing ductwork. This section shall have bolting flanges welded using continuous welds along the casing.
8. Fan shall include extended copper motor grease leads or stainless steel braided: and rigid walled extended electric leads to an externally mounted conduit box.
9. Horizontal mounting feet or clips or vertical mounting clips: inlet bell with safety screen, outlet cone, conventional type shall be provided, as required.
10. Fan shall be balanced to a maximum of 1 mil double amplitude, peak to peak, through the fan's total pitch range.

11. Fan total efficiency shall not be less than 75% at design operating conditions, and shall not vary more than +10% over the entire range of the design system curve.
12. After fabrication, fan shall be cleaned, primed, and coated with two coats of a synthetic polymer based, non-photo chemically reactive, industrial enamel.
13. Fans shall be manufactured by Strobic Air Corporation, Joy, Woods, Buffalo, Greenheck or approved equal.

6.7.28.2 Centrifugal HVAC Fans

1. All centrifugal fans shall be of the double width, double inlet type with backwardly inclined wheels w/ airfoil blades.
2. The fan wheels shall be of carbon steel, mounted on shafts having self-aligning greaseable lubricated pillow-block bearings with 200,000-hour average life.
3. The fan scroll and support system shall be of carbon steel, arrangement 3, Class II or better construction, continually welded seams.
4. The fan motor and fan assembly shall be factory mounted on a common base to allow constant belt tension with no relative motion between the fan and motor shafts. Fan and drive assembly shall be resiliently mounted, so as to isolate 90% of all vibration in all frequency ranges.
5. The fan units shall be balanced at the factory to not exceed 2.5 mils displacement in any axis when measured at the fan pillow block bearing. Additionally, the fans shall not pass through their first critical speed at any catalogued RPM.
6. The fan units shall have a factory applied finish of manufacturer's standard epoxy coating, two coats.
7. Each fan inlet shall have an inlet guard of 1-inch square mesh stainless steel where inlet vanes are not used.
8. Fan drives shall be fixed or adjustable. Guards shall be custom built in accordance with OSHA Standards and be partially and totally removable. Drives shall be fixed on all VFD controlled units.
9. Fan motors shall have TEFC enclosures.
10. Motor speed shall not exceed 1,800 rpm.
11. Fans shall be manufactured by Greenheck, New York Blower, Buffalo, Twin City Blower, Chicago, Barry or approved equal.

6.7.29 Kitchen Ventilation Exhaust System

Kitchen exhaust ductwork shall be tested per code and shall be water tested for leakage prior to finishing walls around the ductwork.

6.7.30 Variable Air Volume Units

1. All VAV boxes shall have reheat coils to maintain space temperatures.
2. For fan powered terminal boxes located above ceilings, return air shall be ducted from a filter grille in the ceiling back to the terminal box. Return filter grille shall be located a sufficient distance from the fan powered box to minimize noise problems. An elbow may be used in the duct between the ceiling filter grille and the box to help reduce noise transmission from the fan back to the room through the grille.

6.7.31 Air Outlets and Inlets

Use care in locating outside air intake relative to exhausts, vent, or other discharges. Do not locate near loading docks, parking areas, or other vehicular traffic areas. Avoid locating inlets near the ground.

6.7.31.1 Diffusers, Registers, and Grilles

Size restroom grilles and diffusers according to State, Federal, and local codes for room size, air quality, etc. Stainless steel, type 304, or aluminum, (satin or brushed finish) shall be used.

6.7.31.2 Fabric Air Distribution Devices

Fabric duct shall be rigid type. Color choices shall be approved by OUP.

6.7.32 Particulate Air Filtration

Air filtration shall be minimum 85% efficiency for air handling systems serving general classroom and office spaces.

This is typically achieved by using a 30% to 40% efficient 2-inch pleat or panel pre-filter and a minimum 85% efficient final bag or rigid box (cartridge) filter.

6.7.33 Central/Local Chilled Water Plants

1. Utilize semi-hermetic compressors rather than hermetic compressors for all HVAC/refrigerant equipment larger than 10 nominal tons, where available.
2. Provide minimum 5-year parts and labor warranty on HVAC compressors 5 tons and less and a 10-year parts and labor warranty on HVAC compressors more than 5 tons.

3. Any new or renovated building containing more than one chiller shall have a variable-primary chilled water pumping system.

6.7.34 Packaged Water Chillers

All chillers shall be installed at a lower overall height than the cooling tower.

6.7.35 Central HVAC Equipment

1. All air handlers and fan coil units shall be located with provisions for sufficient space to service units (e.g., change filters, sheaves, bearings, motors, coils, lubricate components, and replace belts).
2. Drain pans in air handling units and fan coil units shall be double layer insulated, tilted in two directions so it will drain no matter how the unit is set.
3. Temperature sensors shall be installed in the discharge side of all coils.

6.7.36 Air-to-Air Energy Recovery Equipment

1. See DCSM section 5.1 for energy efficiency design guidelines.
2. All lab systems shall be sensible heat-only heat recovery.

6.7.37 Central-Station Air-Handling Units

1. See DCSM section 6.7.42 for general construction requirements for custom packaged air handling units.
2. Use only steam (not hot water) pre-heat coils on air handlers with high outside air percentage.
3. Air handling unit fans shall be specified to mid-range speed instead of near maximum. Units shall be sized so the motor will be smaller horsepower than the maximum allowed for fan size.
4. Except in extraordinary circumstances as determined by the design engineer, air handling units which provide internal isolation for components (e.g., fans) shall not require external isolation.
5. Air handling units shall be of the horizontal draw-thru or blow-thru type or as shown on unit layout drawings and shall contain heating coils, cooling coils, humidifiers, throwaway media filters, control dampers, and either vane axial, plenum or centrifugal fans in accordance with the equipment schedules data sheets.
6. All air handling units shall be designed and constructed so that the fan, filters, coils, humidifiers, dampers and access doors are supported from the unit structure framework and not from the unit panels.

7. Air handlers shall have supply and return fans in air handler not mounted remotely. Architect shall allow mechanical rooms with space for full air handler install and meet code for accessibility without removal of other equipment.
8. Steam coils used for air handlers must be integral face and bypass. Vertical coils and modulating control valve or valves are preferred. If the A/E calls for a two position control valve or valves the controls contractor must install a valve capable of modulation.
9. Chilled water coils shall have a face velocity less than 450 FPM.
10. The mixing box section on the air handler shall have an air mixer. The air mixer shall blend outside air with return air to a uniform temperature and velocity. It shall not allow temperature stratification under any condition or setting on the dampers. It shall be a static device, no moving parts, no maintenance and no adjustments required. The mixer shall have a known pressure drop and velocity with thorough mixing of the air streams that allow no more than a 3 °F variance downstream of the mixer before the heating coil as measured top to bottom of the air handler.
11. All air handlers shall set high enough to allow for full depth of drip legs and steam traps as well as condensate traps for chill water coils. Show an elevation on drawings.
12. Drain pans shall empty with no standing water with air handler in off position and no overflow when running at full capacity.

6.7.38 Indoor Central-Station Air-Handling Units

1. Air handlers shall have supply and return fans in air handler not mounted remotely. A/E shall allow mechanical rooms with space for full air handler install and meet code for accessibility without removal of other equipment.
2. Steam coils used for air handlers must be integral face and bypass, preferred vertical coils and modulating control valve or valves, whether or not a two position valve is called for. Meaning that if the engineer calls for a two position control valve or valves the controls contractor must install a valve capable of modulation.
3. Chilled water coils shall have a face velocity less than 450 FPM.
4. The mixing box section on the air handler shall have an air mixer. The air mixer shall blend outside air with return air to a uniform temperature and velocity. It shall not allow temperature stratification under any condition or setting on the dampers. It shall be a static device, no moving parts, no maintenance and no adjustments required. The mixer shall have a known pressure drop and velocity with thorough mixing of the air streams that allow

no more than a 3 °F variance downstream of the mixer before the heating coil as measured top to bottom of the air handler.

5. All air handlers shall set high enough to allow for full depth of drip legs and steam traps as well as condensate traps for chill water coils. Show an elevation on drawings.
6. Drain pans shall empty with no standing water with air handler in off position and no over flow when running at full capacity.

6.7.39 Packaged Outdoor HVAC Equipment

1. Roof top air handlers should not be used. If they are they must meet the standards for custom air handlers (see DCSM section 6.7.42). The basis of design shall be for a positive or negative pressure of 10 inches WG, roof covered with a Hypalon single-ply elastomeric roof membrane equal to DuPont and shall overlap the sides by 4 inches. They must meet all custom air handler specs.
2. Avoid water coils and piping in rooftop air handling units.
3. If roof top air handlers are used they must not set on a curb but dunnage or framework so water or leaks will not run into the building. Steps and entry must be provided.
4. It is acceptable to use water for heating coils on a mixed air or heat recovery system but it must be glycol treated to at least 33%. If humidifiers are used they must have heat traced drains into the building drain that will always be above freezing not to a roof drain.

6.7.40 Custom-Packaged Outdoor HVAC Equipment

1. When fan motor sizes are 40 hp and above, the use of a 6" I-beam shall be installed along AHU ceiling above the motor to use as a motor monorail.
2. The basis of design for the fan shall be a fan isolated for the AHU angle wall with a Duro Dyne TDC/TDF model #MBX444 flex connector, 10" wide × 1/16" thick.
3. See DCSM section 6.7.42 for general construction requirements for custom packaged air handling units.

6.7.41 Humidifiers

1. Provide high limit on steam humidifiers to prevent spraying liquid condensate into duct system.
2. For steam humidifiers located in air handling units or in supply air ducts, the source of steam shall be the Central Campus Steam Plant high pressure line where practical. Factors including the humidifier location relative to the

steam lines, first cost operation and maintenance costs shall be considered in the selection of the humidifier. This requirement is for comfort humidity, not process.

3. Humidifiers that have a reservoir for water that is heated and cycle for cleaning are not allowed.
4. Other types of humidifiers will be considered but must use a pure water and control possible bacterial growth. Untreated domestic water shall not be used.
5. If we control humidity, the requirements of steam grid humidifiers are:
 - a. Space relative humidity shall be controlled to a design setpoint of 50% (min. 40% and max. 60%) except for special circumstances only after approval by Virginia Tech.
 - b. The distribution manifold shall provide uniform distribution over its entire length and be jacketed by steam. A full length stainless steel internal silencing screen shall be provided.
 - c. The humidifier shall be equipped with an interlocked temperature switch to prevent the humidifier from operating before startup condensate is drained.
6. A/E shall review the location of humidity sensors with ICM.
7. For renovation projects with barrier wall construction, review humidification with existing construction and perform a dew point analysis of existing walls.

6.7.42 General Construction Requirements for Custom-Packaged, Outdoor, Central-Station Air-Handling Units

6.7.42.1 General

1. Custom air handling units shall be a factory-assembled module; these modules will be disassembled to ship then reassembled in the field. All outdoor air handlers shall be custom units but the smaller units can be shipped fully assembled. None shall have added sections or service areas built in place. Doors, roof, walls and all components must be same as the air handler and built at the factory.
2. Design and assemble units to ensure that each enclosure is engineered to withstand 10" WG positive or negative internal pressure, or fan shut-off static pressure, whichever is greater. Leakage shall be less than one-half of one percent of design airflow. Wall, roof, and door panel deflection shall not exceed 1/200 of the span of the panel when operating at 1.5 times schedule fan pressure or a maximum of 10 inches WG static pressure. Floor deflection shall not exceed 1/16" at 1.5 times schedule fan

- pressure or a maximum of 10 inches WG static pressure with a live load of 300 pounds per square foot.
3. Design and assemble units to require only external connection of electrical power, chilled water, hot water, steam, drain piping, controls and ductwork.
 - a. For motor power connections, provide a non-fused service disconnect switch on the exterior wall of the unit. Completely wire service disconnect back to motor cathead inside rigid conduit.
 - b. VFD controls shall be accessible from outside of unit without opening doors of air handler.
 - c. Condensate floor drain or drain pan shall be provided under the cooling coils and can be an integral part of the floor system or out let on side bottom of unit.
 - d. Extend piping connections for each coil, or humidifier (if required) 3 inches through panel casing. Terminate piping with either a flange or a threaded connection at full size and cap.
 4. Factory install all internal electrical components, conduits, electrical conductors, junction boxes, control tubing and piping. All conduits shall be rigid and shall be properly supported and securely attached to units.
 5. Removable panels shall be installed and located to facilitate fan, coil and other major components removal.
 6. Floor drains and drain pans shall be sloped to drain with no standing water.
 7. All conduits penetrating the unit casing shall be sealed airtight. After wire is pulled, conduit shall be sealed so that air cannot be transferred into or out of the unit through conduits. Seal conduit airtight at all filter racks.
 8. Any sheet metal screws placed in unit casing for mounting tubing, conduit, etc., shall have a rubber washer.
 9. Air handling units shall be of the horizontal draw-thru or blow-thru type or as shown on unit layout drawings and shall contain heating coils, cooling coils, humidifiers, throwaway media filters, control dampers, and either vane axial, plenum, or centrifugal fans in accordance with the equipment schedules data sheets.
 10. All air handling units shall be designed and constructed so that the fan, filters, coils, humidifiers, dampers and access doors are supported from the unit structure framework and not from the unit panels.
 11. All casing seams and joints shall be caulked air and water tight.

12. Piping sleeves shall be provided for all pipes, instrument lines and conduit passing through the unit floor. These sleeves must be at least 2" tall and welded to form a water tight seal.
13. Casing fastening bolts, screws or rivets shall be Type 304 stainless steel.
14. Junction boxes or connectors should be provided at shipping split break points and electrical and pneumatic connections and shall be properly tagged for reconnection.
15. Units to be supplied with heavy duty, removable lifting lugs. Each section must have a minimum of four lifting lugs.
16. Filters shall be 90-95 percent efficient. This is typically achieved by using a 2" pleat or panel pre-filter and a final 12" rigid box filter. Final filter cannot be paper or less than 12" deep. Filtration must be 100% no by-pass air.
17. Filters shall be first in air stream but can be after mixing box. All components of the air handler shall be protected by pre and final filters to be 90-95 percent efficient. Return air as well as outside air shall be filter to 90+ percent. No heat wheels or plate heat exchangers or coils shall have less filtration.

6.7.42.2 Enclosure Component Construction

1. Walls and Roof
 - a. Casing shall be double wall insulated sandwich panel construction
 - b. Outer wall shall be 0.040-inch thick embossed aluminum and the inner wall shall be 0.040 aluminum or 22 gauge 304 stainless. Insulation shall be 2-inch polyurethane foam type for walls and roof, having a "U" factor of not less than 0.066 or an R-Value of at least 15.3 and conforming to NFPA 90A requirements.
 - c. For Low Temperature Units a 3" Foam Panel may be utilized. The 3" panel shall have a "U" factor of not less than 0.045 or an R-Value of at least 22.7.
 - d. The basis of design for outdoor units shall be a roof covered with a Hypalon single-ply elastomeric roof membrane as manufactured by DuPont, or approved equal and have a 10-year warranty. Membrane shall overlap sides of unit by 4 inches and covered with an aluminum flashing.
2. Panel Connections

All panel connections shall use aluminum extrusions with a phenolic resin thermal break for no through metal construction. Where these extrusions

intersect, they will be continuously welded for strength and to form an airtight seal.

3. Flooring

- a. Flooring shall be of 3/16" thick aluminum thread bright or stainless steel. All seams shall be continuously welded to form a water tight assembly.
- b. The floor plate shall turn up 2" on the inside perimeter of the unit to form a 2" high containment pan.
- c. Under-floor is insulated with 2 inches of sprayed-on polyurethane foam and covered with 0.040 aluminum or 22 gauge or heavier galvanized steel skin.

4. Access Doors

- a. Access doors shall be 2'-0" wide × 6'-0" (minimum) high provided as walk-in access to each air handling unit section. Doors shall be wide enough to remove motors and all other replaceable unit components. Doorframes shall be of welded, mitered extruded aluminum with a thermal break and welded at the corners. Door shall be made of insulated sandwich panel construction matching the unit casing.
- b. Doors shall have perimeter airtight double sealing replaceable gasket. Door sealing gaskets shall be neoprene, 3/4-inch wide × 5/16-inch thick sponge rubber.
- c. All doors shall be equipped with a 3-point latching system, which shall open from both sides of the door. The latches shall be a composite handles with 304 stainless steel mechanisms. Doors shall be attached to the casing with a continuous stainless steel hinge. Handles shall be accessible without the use of a ladder.
- d. All doors shall be installed to open against the greater air pressure or with a second catch for the door.
- e. All doors, which leak or do not otherwise operate properly, shall be repaired or replaced at the manufacturer's expense before being shipped.
- f. All doors to have a 12" × 12" double pane, thermal reinforced safety glass viewing window.
- g. Outside units will have a 4" rain guard over each door and removable panel.

5. Access Panels

Removable access panels, located at each coil and fan shall be provided to facilitate removal of each coil and fan. The removable panels shall be

constructed the same as an access door except that each removable panel shall be screwed in place on 6" centers.

6. Frame and/or Base

- a. Base shall be constructed from standard structural steel wide flange, channel, and angle sections of adequate size to prevent any deflection or sagging of unit housing, or internal components during lifting, shipping, unloading or operation. No preformed shapes or angles will be allowed in the base construction.
- b. When two or more units are stacked on top of each other, the structural integrity of the base unit(s) shall be sufficient to support the upper operating unit.
- c. Sealant shall be installed between panels at all joints, between panels and trim, and between panels and base channels to provide an airtight enclosure. Permanently flexible sealant recommended for this application by manufacturer.
- d. Access to all doors shall be provided by permanent walkway or steps.

7. Fan Section

- a. Draw-through units are preferred for most applications.
- b. Bell-mouth transitions to fan intakes and outlets. Outlets should not be in the fan section near fan wheel.
- c. In multiple fan installations each fan shall have a VFD where there is only one supply and one return fan they shall have a by-pass that is full line voltage not pulse wave or DC converted.
- d. Fan and drive assembly shall be resiliently mounted, so as to isolate 90% of all vibration in all frequency ranges.
- e. The fan units shall be balanced at the factory to not exceed 2.5 mils displacement in any axis when measured at the fan pillow block bearing. Additionally, the fans shall not pass through their first critical speed at any catalogued RPM. Direct drive fans shall be balanced to a maximum of 1 mil double amplitude, peak to peak, through the fan's total pitch range.
- f. The fan wheels shall be mounted on shafts having self-aligning greaseable lubricated pillow-block bearings with 200,000-hour average life.
- g. Fan shall include extended motor grease leads stainless steel or stainless steel braided: and rigid walled extended electric leads to an externally mounted conduit box.

- h. Fan total efficiency shall not be less than 75% at design operating conditions, and shall not vary more than + 10% over the entire range of the design system curve.
- i. Motor speed shall not exceed 1,800 R.P.M.

6.7.42.3 Fan Installation Requirements

When fan motor sizes are 10 hp and above, an I-beam shall be installed along AHU ceiling above the motor to use as a motor monorail.

6.7.42.4 Steam Grid Humidifiers

1. Only direct steam injection shall be used with an upstream of the control valve pressure of 10 psi steam (power plant steam or pure steam generator with pure water connection in a mechanical room, not outside).
2. Basis of Design: Armstrong series 9000 or 1000 humidifier.
3. Steam shall be dry strained and silent. Dispersion tubes cannot spit water at any time during run cycle. The distribution manifold shall provide uniform distribution over its entire length and be jacketed by steam. A full length stainless steel internal silencing screen shall be provided.
4. The separating chamber shall be of a volume and design that will discharge and remove all water droplets and all particulate matter larger than 3 microns when humidifier is operating at maximum capacity.
5. Control valve shall be able to accept a 0-10 volt signal. The metering valve shall be stainless steel, shall be integral within the body of the humidifier, and shall be jacketed by steam at supply pressure and temperature to prevent condensation. The stainless steel metering valve shall be a parabolic plug.
6. The humidifier shall be equipped with an interlocked temperature switch to prevent the humidifier from operating before startup condensate is drained.
7. Humidifier section of air handler shall be stainless steel top to bottom internally.

6.7.42.5 Mixing Box

1. Mixing box shall be factory fabricated and have the same finish and insulation as the unit casing. If unit is shipped unassembled, supplier shall furnish all bolts, screws, fasteners and gaskets required for assembly.
2. Shall be the same as all air handling units described in DCSM section 6.7.38 for indoor central-station air handling units.

3. Dampers shall have manual locking quadrants unless otherwise specified.

6.7.42.6 Drain Pans

1. Intermediate drain pans: Provide 16 gauge 304 stainless steel drain pans under all cooling coils as indicated. Cross brace pan to drain connection.
2. The pan shall be sloped to allow proper drainage. The condensate drainpipe shall be stainless steel and welded into the deep end of the sloped drain pan. Drain pipe to be extended 3" through the base steel and capped.

6.7.42.7 Steam Heating Coils

1. Fins shall be aluminum or copper plate fin type with full fin collars for accurate spacing and maximum fin-tube contact. Fin spacing shall not be closer than 10 fins per inch unless otherwise shown on the submittal data and drawings.
2. Vertical integral face and bypass steam coils with a tube thickness of 0.049" or heavier.
3. Headers shall have removable covers for repair of tubes at header.
4. Steam coils are leak tested at 315 psig (dry air) for standard steam coils and 500 psig (dry air) for high pressure steam coils at the factory. Coils are to be pressurized then completely submerged in water containing a wetting agent.

6.7.42.8 Chilled Water Coils

1. Chilled Water Coil acceptable manufacturers are:
 - a. Aerofin
 - b. Marlo
 - c. Heatcraft
2. Tubes shall be round, seamless copper tubes, $\frac{5}{8}$ " O.D., arranged in counter flow pattern with respect to airflow. Bronze spring type turbulators shall be used at water velocities below 8 fps. Tube thickness shall not be less than 0.05 times the O.D. of the tube.
3. Fins shall be plate-type aluminum or copper. Fins continuous across entire coil length and up to 54" in height and die-formed in multiple stages with full fin collars for maximum fin-tube contact and accurate spacing. Fins mechanically bonded to tubes. Fin spacing shall not be closer than 12 fins per inch unless otherwise shown on the drawings.
4. Casings to be 304 stainless steel. 16 gauge formed end supports and top and bottom channels. One 16 gauge 304 stainless steel center tube

support on lengths over 48"; Two or more supports on ordering lengths over 96".

5. Water coils are leak tested at 315 psig (dry air) for standard water coils and 125 psig for water coils with removable headers at the factory. Coils are to be pressurized then completely submerged in water containing a wetting agent.
6. Headers shall be constructed from UNS 12200 seamless copper conforming to ASTM H55. Return and supply headers are located on the same side of the coil. Connections to be extended through panel wall unless coils are internally piped. Connections to be carbon steel or red brass.
7. Coils sized to allow design CFM to flow under 500 FPM through coils. (Exception – sized less than 450 FPM for 100% outside air units.) The coils shall be able to flow 15% above maximum total air flow without carryover of moisture. If carryover occurs stainless steel mist eliminators shall be installed by manufacturer.

6.7.42.9 Hot Water Coils

1. Hot Water Coil acceptable manufacturers are:
 - a. Aerofin
 - b. Marlo
 - c. Heatcraft
2. Tubes shall be round, seamless copper tubes, $\frac{3}{8}$ " O.D., arranged in counter flow pattern with respect to airflow. Bronze spring type turbulators shall be used at water velocities below 8 fps. Tube thickness shall not be less than 0.05 times the O.D. of the tube.
3. Fins shall be plate-type aluminum or copper. Fins continuous across entire coil length and up to 78" in height and die-formed in multiple stages with full fin collars for maximum fin-tube contact and accurate spacing. Fins mechanically bonded to tubes. Fin spacing shall not be closer than 12 fins per inch unless otherwise shown on the drawings.
4. Casings to be continuous coated galvanized steel, stainless steel or aluminum as required. 16 gauge (through 33" wide), 14 gauge (36" through 48" wide), formed end supports and top and bottom channels. One 16 gauge continuously coated, galvanized steel center tube support on lengths over 48"; Two or more supports on ordering lengths over 96".
5. Water coils are leak tested at 315 psig (dry air) for standard water coils and 125 psig for water coils with removable headers at the factory. Coils

are to be pressurized then completely submerged in water containing a wetting agent.

6. Headers shall be constructed from UNS 12200 seamless copper conforming to ASTM H55. Return and supply headers are located on the same side of the coil. Connections to be extended through panel wall unless coils are internally piped. Connections to be carbon steel or red brass.

6.7.42.10 Dampers

1. Control dampers shall be opposed blade type. The basis of design for opposed blade dampers shall be Ruskin-CD50 series or equal.
2. Joints shall be tight and uniform width. Dampers shall be free of visible burrs and cuts.
3. Supplier shall furnish construction details of all dampers.
4. Dampers shall be aluminum construction. Damper frames shall be formed of 0.063" aluminum, mechanically joined. Blades shall be airfoil design of aluminum construction. Blades to have a nominal width of 6 inches with a maximum width of 8 inches. Furnish dampers with jackshafts and locking quadrants.
5. The basis of design for damper seals shall be dampers provided with Santoprene™ blade seals and self-compressing stainless steel side seals. Linkage shall be 1/8" rolled steel, zinc plated, concealed in end channel frame. Blade pin shall be 3/8" square steel, zinc plated.
6. Damper shall be capable of closing or opening against 1.5 times the static pressure of the unit.

6.7.42.11 Outside Air Intake Hoods

1. Outside air intake hoods shall be fully welded 0.090" aluminum or 14 gauge 304 stainless steel. Bird screen shall be 0.5" × 0.051" aluminum hardware cloth and be contained within a removable frame.
2. Hood design shall incorporate all structural supports to withstand a wind load of 100 mph.
3. Color shall be mill finish.
4. Louver shall be sized for the design C.F.M. at 850 feet per minute, face velocity based upon louver net free face area.

6.7.42.12 Electrical

1. Lighting and Receptacles
 - a. Provide a marine type waterproof light fixture with 150 W equivalent rough service bulb, rated for 125 V, in each housing module capable of 10 foot-candles minimum lighting.
 - b. Provide a GFCI receptacle under light switch at fan section door with a weatherproof self-closing cover.
 - c. Light switches and receptacles shall be approved for outdoor installation. The basis of design for light switches and receptacles shall be those rated for 20 A as manufactured by Hubbell.
 - d. Conduit shall be $\frac{3}{4}$ " or larger for lights and power. All conduits shall be sealed outside and inside between air handler section to prevent air from passing from one section to another. This may need to be done after installing but should be on check list.
2. Power: Install a non-fused disconnect switch, as required for complete and operable system.
3. Wiring and Conduits
 - a. All electrical wiring shall be installed in Rigid Conduit, minimum size of $\frac{3}{4}$ inch.
 - b. Use liquid tight flexible metal conduit at motors, transformers and any device subject to vibration and where rigid conduit is not applicable; however, each length of flexible conduit shall not exceed 48 inches. The basis of design shall be Crouse-Hinds Type XD expansion or deflection joints.
 - c. The use of EMT is not permitted.

6.7.42.13 Controls

1. All controls and operators will be provided by the controls contractor to be factory installed or field installed as noted in the bid documents. Controls shall be designated on the shop drawings or bib drawings for location and type.
2. Control sequence of operation and P&ID layout drawing to be provided to unit manufacturer for controls installation from the engineer or contractor.
3. All controls shall be Siemens or Siemens Apogee compatible. Third party software is not to be used. If the only controller is by another manufacturer then it will have a complete interface provided by

equipment manufacturer. If BACNet is used a list of control points with read and write access will be provided.

4. At least one $\frac{3}{4}$ " conduit cap on both ends shall be provided between sections of the air handler for control wiring. This conduit shall be filled or plugged by the controls contractor after work is complete.

6.7.42.14 Wiring Installation

1. All power, lighting, control, and instrumentation wiring shall be installed in Rigid Conduit. The use of EMT is not acceptable.
2. Separate conduit systems shall be provided as follows:
 - a. Power Circuitry
 - b. Lighting Circuitry
 - c. Control and Instrumentation Circuitry
3. All conduit connections to boxes and fittings shall be supported not more than 12 inches from connection point. All conduit bends shall be supported not more than 12 inches from each change in direction.
4. Flexible conduit shall be used to connect conduits to motor. The maximum allowable length of flexible conduit shall be 4 feet.
5. Power and control and instrumentation wiring shall be separated from each other and shall not be terminated on the same terminal blocks.
6. Identification
 - a. All control and instrument wiring shall be identified with a unique wire number.
 - b. These numbers shall agree with the numbers shown on the supplier's wiring diagrams.
 - c. Control circuit wiring shall be permanently identified with wire markers applied within 1" of each terminal and splice.

6.7.42.15 Final Cleaning at Factory

1. The outside and particularly the inside of each air handling unit shall be thoroughly cleaned.
2. Industrial grade cleaners can be used to remove construction dust. Any sheet metal mil finish or grease can be removed with an environmentally safe and non-toxic C9-C12 Propanol Hydrocarbon.
3. All proposed cleaning materials shall have contents identified and approved prior to use.
4. Unit openings shall then be covered with sheet-metal. The unit shall be wrapped with 7 mils of shrink wrap and heated to maintain unit cleanliness standards for shipping.

6.7.42.16 Execution

1. Unit manufacturer shall provide a qualified supervisor to instruct and supervise the Contractor in rigging, erecting, pre-operation checkout and starting of each unit as necessary. The price for such services shall be indicated in the unit manufacturer's quote. Manufacturer's supervisor shall be a senior service technician trained in the startup of industrial HVAC Systems not a factory worker.
2. If unit is run by the contractor the filters will be installed and changed when the static pressure is above 1" WG across the filter bank unless the EOR gives a written statement to use a higher static pressure. If air is drawn from a different location than the unit filter bank then it will equal or exceed the 90% filtration of the unit.

6.7.42.17 Tests at Jobsite

1. All units will be field tested by an independent testing/balancing contractor after installation. Any deficiencies found at this time will be corrected at the cost of the unit manufacturer.
2. Unit manufacturer shall provide a qualified service technician to be present at the job site when air handling units are tested by the testing/balancing contractor. It is the responsibility of the unit manufacturer to see that all necessary corrections are made and the units are performing in accordance with the specification. One day shall be provided in base bid for this work.
3. Unit manufacturer shall provide a qualified technician to instruct the University's personnel on maintenance and operation of the air handling units for a minimum of one day after installation. If this is not done a refund for the service will be rendered.
4. It is the responsibility of the unit manufacturer to coordinate with the VT PM to establish a schedule for the events previously described.

6.7.42.18 Warranty

1. These units will be guaranteed free of defects for a period of one year from building completion and all components in the air handler are operational.
2. All work and workmanship is done by highly trained professionals and their workmanship shall be guaranteed for a period of one year.
3. The warranty of all components will be the manufacturer's standard warranties serviced by the air handling unit manufacturer. If the manufacturer will not warranty the unit from the completion date of the

project, the Contractor shall provide warranty coverage for the full 12 months.

6.8 ELECTRICAL SYSTEMS

6.8.1 Common Work Results for Electrical

1. General Electrical drawings
 - a. Provide a legend for all symbols and abbreviations used. Delete any symbols which are not used for the specific project.
 - b. All spaces and rooms shall be labeled.
 - c. New work shall be differentiated from that which exists. Include all existing equipment on the one-line/riser diagram that pertains to any new work on the one-line/riser diagram.
 - d. For multi-level buildings, provide a floor plan for each level affected.
 - e. Show panelboard, disconnect, starter, transformer, and equipment/appliance locations on floor plans.
 - f. Light fixture schedule shall be provided on drawings. Show all lighting fixture types in the schedule. Show input watts per fixture for each fixture type.
2. Electrical Room drawings
 - a. All electrical rooms or rooms containing new/renovated equipment (service entrance equipment, electrical panels, transformers, etc.) shall be drawn at a minimum of 1/4" scale.
 - b. Show required clearances with faded dashed lines.
 - c. All required door swings, and door hardware shall be noted and cross referenced to architectural drawings if submitted as a set.
3. Electrical Details

The following items require details to include all dimensions, materials, and location of construction to include distance above or below floor/finished grade:

 - a. Duct bank
 - b. Housekeeping/equipment pads
 - c. Lighting switching – by tick marks, switch notation, or drawing notes. Lighting circuits are always required regardless of how the switching is indicated.
 - d. Grounding detail for service entrance and individual transformers. Show grounding conductors, electrodes, and lighting protection system (where required): Sizes, materials, and associated conduits. Use of “per NEC” is not acceptable.

- e. Grounding riser diagram where generators, transfer switches, main-tie-main switchboards, or separately derived systems (aside from individual transformers) exist.
 - f. Arc-flash warning labels as required by NEC 110.16. Refer to DCSM section 6.8.4.6 for requirements.
4. Electrical Calculations
- Provide the following calculations with the submittal of working drawings:
- a. COMCheck verification.
 - b. Demand load for all switchboard, panelboards, and feeders to multiple loads in tabular form.
 - c. Voltage drop calculations showing no more than 2% for feeders, and 2% for exterior branch circuits that feed lighting or equipment not mounted to the building.
 - d. Photometrics of emergency lighting along the entire path of egress at same scale as floor plan included in working drawing submittal. NOTE: If egress paths are not indicated on the plan, it will be assumed that the lighting levels for the entire room or area will need to meet the required illumination levels required by the VCC and IESNA.
 - e. All lighting and lighting calculations shall be provided in accordance with the latest edition of the IESNA Handbook, and applicable energy codes.
 - f. Lightning protection system calculation.
 - g. Provide a load analysis, calculation or evidence to show that the existing panels, gear and feeders are not overloaded.
5. Fire-Rated Assemblies
- a. All fire rated walls shall be noted on power and lighting sheets. Fire rating shall match ratings indicated on architectural sheets.
 - b. Provide a listed detail for all fire-rated penetrations.
6. Clearance Markings
- a. A 2" wide yellow line shall be painted on all concrete floors in electrical rooms and closets indicating the electrical working space as defined by the NEC.
 - b. The space dimensions shall be provided by the design professional on the contract drawings.
 - c. Stencil "NO STORAGE - ELECTRICAL WORKING SPACE" in 2" high, yellow letters centered in the space outlined area.
7. Mechanical Equipment
- a. Provide coordination between mechanical and electrical drawings for means of disconnect for all mechanical equipment. Where a means of disconnect must be provided by the electrical contractor, provide

- coordinated drawings specifying the location, means of support, and means of connection to the equipment. Locate disconnects as close as possible to equipment.
- b. Dashed or faded outlines shall be provided for all mechanical equipment on drawings. Provide notes as required to indicate clearances for maintenance, installation, or provisions for servicing. Coordinate with mechanical drawings.
 - c. All mechanical equipment used to evacuate smoke, fumes, or provide heating in support of life safety equipment such as sprinkler pipes, shall be provided a circuit breaker locking device in the associated panelboard.
 - d. Coordinate placement of lights around equipment such that working areas are illuminated.
8. 4-Wire Delta Systems
- a. No 4-Wire Delta systems are permitted to be used in new construction.
 - b. Where 4-wire delta systems exist, they may be reused, but all elements of the system must be brought up to current standards when modified. Modification includes disconnection, connections, and reconfiguring of any part of the system.
 - c. Provide labels, grounding, color coded conductors, etc., as required by the latest edition of the NEC as adopted by the State of Virginia.
9. Circuit and Equipment Designations
- a. All circuit designations shall be provided in such a manner that any drawing sheet may stand on their own for purpose of circuit designation. Circuits shall be provided with circuit numbers, conductor and conduit sizes as a minimum.
 - b. All equipment designations shall be provided in such a manner that any drawing sheet may stand on its own for purpose of equipment designation.
 - c. No references to index sheets shall be used for the purpose of identification of circuits or equipment.
10. One Line Diagram/Schedules
- a. Show Fault Currents at each panel, motor control center (MCC) and generator transfer switch affected by the project. Show the AIC rating of electrical equipment.
 - b. Show size and type for all service and distribution equipment, transformers, panelboards, and major equipment as well as disconnect switches. For transformers, indicate kVA as well as primary and secondary voltages.

- c. Show all feeder sizes and types. Show type of conductor and raceway. Show all fuse and circuit breaker sizes, conduit and wire sizes, wireway and trough sizes.
 - d. Show all grounding electrodes and their types. Size all grounding electrode conductors and equipment grounding conductors.
 - e. Provide switchboard and panelboard schedules with fuse and breaker sizes, wire sizes, load in kVA, voltage, phase, size in amps, and AIC rating. Indicate if panel is MLO or MB.
 - f. Disconnects-Show size and type as well as AIC rating.
 - g. Show separation of emergency wiring and equipment from all other wiring. Label emergency branch, standby branch and normal branch..
11. Environmental Initiative Documentation: All design aspects to include existing conditions, material use and disposal, and commissioning shall be documented on the drawings and identified as being mandatory for the evaluation of the project with respect to the certification being sought.
 12. Points of Contact: All pertinent points of contact for construction efforts shall be documented in the drawings to include University representatives, construction managers, utilities, fire alarm, and communications contractors where known.
 13. Dig Notice: Where digging is required as part of the construction effort, include "Contact Virginia 811 at 811, 1-800-552-7001, or <http://www.va811.com> no less than 72 hours prior to excavation and do not disturb the soil until dig ticket has been processed." on the working drawings.
 14. Specifications: Provide complete specifications for electrical work.
 15. Electrical Building Design
 - a. Electrical closets and distribution shall be centrally located throughout the building.
 - b. Access doors to crawl spaces shall be located as close as possible to electrical equipment under floor.
 - c. Provide separate electrical and telecommunications closets. Custodial closets shall not be used to house electrical or telecommunications equipment.
 - d. Provide Ethernet connection in all main electrical rooms.
 - e. Each electrical room shall have 50% usable spare wall space for future growth.
 - f. Provide one duplex receptacle for each floor level stair landing.
 - g. USB recharging ports shall be added to lounges, student areas, and study areas.

- h. Corridor wall receptacles (primarily used for floor cleaning equipment) shall be circuited separate from interior office/classroom receptacles.
- i. Electrical wiring system shall be designed and installed with as much flexibility as practical and reasonable.
- j. In demolition associated with renovations, all wire shall be removed back to the panel board or source of power and all accessible conduit shall be removed.
- k. In atriums or other multi-story open to roof areas, accessibility and maintenance shall be a consideration when mounting lights.
- l. All spaces with mechanical equipment, including interstitial spaces shall maintain an evacuation route, clearly marked for egress.
- m. See DCSM section 5.1 for energy efficiency guidelines.
- n. Floor boxes are prohibited in new construction and renovation projects. If a waiver is given for floor boxes, provide 30% attic stock of replacement covers.

6.8.2 Low Voltage

6.8.2.1 Operation and Maintenance of Low Voltage Electrical Distribution

The Contractor shall submit warranties and guarantees in one commercial quality, hardback binder sized to accommodate 8.5 by 11 inch pages, with a table of contents and two copies of each warranty or guarantee. Marked tabs shall separate warranties and guarantees in sections following the order of the specifications.

6.8.2.2 Low Voltage Electrical Power Conductors and Cables

1. For new construction or renovation projects, the use of MC cable is not permitted. Use of AC cable is not permitted. Use of BX cable is not permitted. Use of MI cable is not permitted. Should state that Flexible Metal Conduit (FMC) may be used per DCSM section 6.8.4.3.
2. Use of NM cable is not permitted except for R-5, individual dwelling unit.
3. All conductors shall be copper, 600 V, THHN/THWN with moisture resistant insulation.
 - a. All power conductors shall be AWG #12 or larger.
 - b. Minimum control wire shall be AWG #14 and minimum signal wire size no smaller than AWG #18.
 - c. All AWG #12 and smaller wire shall be solid conductors and AWG #10 and larger wire shall be stranded.

- d. Exceptions can be made for UL factory-supplied cables.
- 4. All single conductor wire shall be in conduit.
- 5. Neutrals shall not be undersized.
- 6. No shared neutrals allowed.
- 7. Under-carpet electrical power systems are not allowed for capital projects or new construction.
- 8. Identification:

Building system wiring shall be color coded as indicated:

<u>208 V</u>			<u>480 V</u>		
Neutral	-	White	Neutral	-	Gray
Phase A	-	Black	Phase A	-	Yellow
Phase B	-	Red	Phase B	-	Brown
Phase C	-	Blue	Phase C	-	Orange
Ground	-	Green	Ground	-	Green

- 9. Busway:
 - a. Include the following paragraph in specifications for busway systems:

“The busway shall not be energized until the A/E has received and reviewed a letter from the Contractor and a Commonwealth of Virginia Licensed Professional Engineer provided by the Contractor, certifying that the installation was inspected and it was determined that the entire bus duct system has been properly installed in accordance with the bid documents, including approved shop drawings and/or manufacturer’s instructions for this project.”
 - b. The certification of this work shall include the torqued pressure used to tighten bolts at all spliced joints in the busway system.

6.8.2.3 Low Voltage Distribution Transformers

- 1. Building supply transformers shall have copper windings. Transformers supplying individual equipment may be copper or aluminum.
- 2. Transformers supplying non-linear loads (computers, copiers, printers, etc.) shall be K-factor rated.
- 3. Transformers shall not be stacked.
- 4. The maximum size of a wall mounted transformer shall be 15 kVA.
- 5. Where it is necessary to mount a transformer above the floor, double doors to the space shall be provided.
- 6. Floor mounted transformers shall be installed on 4" housekeeping pad.
- 7. Consider location of IT equipment when locating transformers.

6.8.2.4 Low Voltage Circuit Protective Devices

Provide disconnect switches, other than circuit breakers, to elevator main disconnect. Provide disconnect and shunt trip in the elevator mechanical room.

6.8.3 Service and Distribution

6.8.3.1 Medium Voltage Electrical Distribution

Voltages greater than 600 volts shall be used for utility distribution only per NEC Article 328.

6.8.3.2 Switchboards and Panelboards

1. A laminated one-line diagram of normal and generator electrical system shall be posted in the main electrical room or in vicinity of distribution panel or switchboard.
2. Do not locate panelboards in custodial closets.
3. Panelboards shall be surface mount in rooms with hard ceilings.
4. Switchboards, switchgear and panelboards shall be provided complete with all mounting hardware for mounting any size breaker that the panel will accept.
5. For distribution and switchboards, breakers shall be plug-in type. Panelboards shall be bolt-on type.
6. Provide a minimum of one 60 amp, 30 pole 120/208 V, 3 phase panelboard per NI&S closet.
7. Provide a minimum of one 100 amp, 30 pole 120/208 V, 3 phase panelboard per laboratory closet.
8. Provide 40% spare breaker space in each new main distribution panel, main switchboard, and main switchgear for all new buildings. Provide 20% spare circuit breakers in each new panelboard. This also applies to new panels in existing buildings.
9. Panels and switchboards which utilize obsolete styles of breakers shall not be used to feed new equipment. Obsolete breakers include breakers no longer manufactured by the original equipment company or the original equipment company is no longer in business. VTES has first right of refusal for old breakers.
10. For new construction:
 - a. Half-size breakers are not allowed.
 - b. Tandem breakers are not allowed.

11. All panelboard indices shall identify all equipment served by each circuit (e.g., Rcpt - Rooms 111, 112, 115).
12. All spaces shall be fully bussed.
13. All busses shall be copper.
14. Wiring in gutter space shall be performed in a neat and workmanlike manner. Bends shall be made at 90 degrees whenever possible.
15. Panels shall only serve loads for the floor/level on which they are installed. Exceptions may be made for mezzanines, penthouses, rooftop units, etc.
16. For flush mounted panels, provide a 1" empty conduit for every 4 spaces/spares. Extend to above ceiling. If panel is located on an upper floor, extend half of spare conduits above ceiling, half of spare conduits below floor into accessible space.
17. Exterior mounted panelboards, automatic transfer switches and switchboards shall be in fiberglass or stainless steel enclosures or have a roof over them. Architectural features should be considered when determining enclosure type.
18. When mounting exterior panelboards on channel, the channel shall be aluminum or stainless steel.
19. Series rating is not allowed.
20. Load centers will not be permitted.
21. Feed-through or sub feed-through are not allowed, with the exception of side-by-side panels.

6.8.3.3 Motor Control Centers

Use motor control centers when the total installed cost of the motor control center (MCC) will be less than individual starters, typically when there are more than three 480 V motor loads that require controllers. Avoid using MCCs for distribution switchgear when switchboards and panelboards are more economical. Locate MCCs in room containing motors served.

6.8.3.4 Wiring Devices

1. All wiring devices shall be industrial heavy duty specification grade, rated a minimum 20 A, 125 V.
2. Switches shall be rated a minimum of 125V/277V.
3. Use side-wired devices; back-stabbing is not permitted.
4. Label all receptacles and switches with panel and circuit number.
5. Mounting Heights: note mounting heights on drawings. Devices include but are not limited to: heights for light switches, receptacles, plugmold,

indicator lights, and card readers. (Note: all dimensions are from finished floor. Dimensions may be adjusted with architectural requirements as long as no code restriction is violated). Comply with the latest edition of ADA Standards for Accessible Design.

6.8.3.5 Fuses

Provide 10% spare fuses for each type used of 60 A or larger, minimum quantity of two. Coordinate delivery and storage location with VT PM and VTES.

6.8.3.6 Enclosed Switches and Circuit Breakers

Switches and disconnects (not to include wiring devices) shall be quick make, quick break type with lockout capability.

6.8.3.7 Variable Frequency Motor Controllers

1. See DCSM section 6.7.3 for common motor requirements for HVAC equipment.
2. See DCSM section 6.3 for BAS design standards.
3. All motor variable frequency controls shall meet IEEE recommended practices and requirements for harmonic control in electrical power systems. See IEEE Standard 519.
4. VFDs shall be pulse type (12 pulse where needed).
5. Maximum speed for motors on VFD shall be 60 Hz. Maximum speed for motors to not exceed its nameplate.
6. Avoid installing disconnect switch between VFDs and motors unless required by code. If required, provide auxiliary contacts to disable VFD.
7. VFDs installed more than 100 feet from their motor shall be provided with a harmonic filter. If VFDs are installed greater than 150 feet from their motor, "drive cable" shall be used in addition to a harmonic filter.
8. The basis of design manufacturers shall be Square D and ABB.
9. All VFDs shall be provided with a manual type constant speed bypass circuit. The bypass circuit shall be provided in the drive enclosure.
10. Provide isolation transformers in a separate enclosure.
11. VFDs shall be provided with an input line reactor. Total impedance at the input terminals shall be no less than 5%.
12. Electrical output for VFDs shall not exceed 10% Total Harmonic Distortion (THD).
13. The VFD's power supply shall not be used for any external use. If 24 Vdc is needed, an external power supply shall be added.

14. All VFDs shall have BACnet communications protocol available.
15. VFDs shall be clearly labeled with panel, circuit, and equipment designations.
16. All VFDs shall have an efficiency rating of 98% or higher at full load.
17. All VFDs shall be started-up and programmed by a factory certified technician for that manufacturer.
18. Complete the VFD prestart-up checklist and provide to technician prior to factory start-up. See the See the VT Design Standard Forms Library for the Variable Frequency Drive Start-Up Checklist.

6.8.4 Building Electrical Systems

6.8.4.1 Grounding and Bonding for Electrical Systems

Along with every feeder and branch circuit, install a 600 V insulated copper wire as an equipment grounding conductor. Bond to every metal outlet box with a device, to all utilization equipment and land on the ground bar in the originating panel. Wire insulation shall be green or identified as required by applicable code.

6.8.4.2 Hangers and Supports for Electrical Systems

1. Utilize steel slotted channel where applicable for support system. For interior applications, use galvanized steel channel. For exterior systems or wet/damp rooms, utilize aluminum or stainless steel.
2. Utilize steel or iron hangers, clamps, etc.
3. Minimum hangar rod size for raceway supports is ¼".

6.8.4.3 Raceway and Boxes for Electrical Systems

1. Flexible metal conduit shall be used only for connections to lighting fixtures, vibrating equipment, where flexibility is required or where crossing an inaccessible ceiling, wall or chase. Whips to lighting fixtures may be ½", maximum 6' length (whips shall be as short as practical, but no longer than 6').
2. Provide liquid-tight flexible metal conduit in wet or damp locations. All other conduit systems shall be ¾" minimum. Single-receptacle drops in existing walls may use ½" flex.
3. Conduit shall be utilized as follows at a minimum:
 - a. Rigid galvanized conduit (RGC) – where subject to damage or in exposed exterior locations. Utilize threaded fittings. Install as to be watertight.

- b. Rigid nonmetallic conduit (RNC) PVC Schedule 40 below grade.
Transition to RGC starting at the elbow before conduit emerges from below grade.
 - c. Liquid tight flexible metallic conduit (LFMC), for equipment connections.
 - d. Electrical Metallic Tubing (EMT) otherwise or where indicated.
4. All empty conduit shall have a 65-pound test polymer (or equivalent) pull string tied off at both ends.
 5. For weather proof receptacle boxes, use metal in-use covers. Plastic covers are not acceptable.
 6. Device cover plates shall be either stainless steel, nylon or unbreakable thermoplastic. For renovation work, match existing cover plate material and color.
 7. No back-to-back boxes unless the spaces are separated by a low wall or framed opening.
 8. Paint all conduit in wet locations, conduit in damp locations, and exposed conduit, boxes and supports except in electrical rooms, mechanical rooms and janitors closets.
 9. Paint all exposed exterior conduit and boxes with two coats of paint unless fiberglass, aluminum or stainless steel.
 10. For renovation projects, surface raceways shall be provided in finished areas only where raceway cannot be concealed. Surface raceway shall transition to EMT above finished ceiling.
 11. All piping and conduit shall be run parallel and perpendicular to building structure (walls, ceiling, floors) and existing conduit.
 12. Fire alarm conduit systems shall comply with DCSM section 3.10.6.
 - a. All junction box covers in the fire alarm conduit system shall be painted red.
 - b. A change in the location of any device or panel must be approved by the UBO as well as the engineer whose stamp appears on the fire alarm design drawings.

6.8.4.4 Underfloor Raceways

The use of underfloor raceways for electrical systems is not allowed.

6.8.4.5 Identification for Electrical Systems

1. Panelboard designations:

Panel Type, Voltage, or Locator	Identifier Code
Mains	
Main distribution panel	MDP
Main switchboard	MSB
Main switchgear	MSG
Other Distribution and Branch Panels	
Emergency	E (if applicable)
Distribution Panel	DP (if applicable)
Voltage	LV or HV
Floor	B, 1, 2, etc.
Panel Identifier	A-Z
Sub-Panel Identifier	1, 2, 3, etc.

2. Examples of panelboard labelling:
 - a. The third of three 480 V, emergency panels on the fourth floor would be designated EHV4C.
 - b. The first panel for a 208 V panel on the first floor would be designated LV1A. This panel's first subpanel would be designated LV1A1.
 - c. The first 208 V emergency distribution panel located in the basement would be designated as EDPLVB1.
3. For existing facilities, existing panelboard labeling plan shall be maintained and extended for all new panels.
4. Label all receptacles and utilization equipment with panel and circuit number.
5. Label all junction boxes with panel and circuit number.

6.8.4.6 Overcurrent Protective Device Coordination and Arc-Flash Studies

1. Final electrical installation shall include all arc flash labeling as required by NFPA 70E. Labels shall be on outside of equipment, not inside panel covers.
2. For new construction and capital projects, all calculations for labeling provided shall be submitted to the VT PM at project turnover. Provide labels listing limits of approach, incident energy, arc flash boundary, etc.
3. For renovation projects, match style of labels on the panel(s) feeding the new panel(s).

6.8.5 Power Generation

6.8.5.1 Facility Electrical Power Generating and Storing Equipment

1. Emergency Systems (NEC 700): All equipment, conductors, and conduits associated with emergency systems shall be clearly identified with drawing notation and physical labels. Emergency systems will be kept separate from all other systems as described in the NEC.
2. Legally Required Standby Systems (NEC 701): All equipment, conductors, and conduits associated with legally required standby systems shall be clearly identified with drawing notation and physical labels. Optional standby systems shall not share conduit and enclosures with other systems.
3. Optional Standby Systems (NEC 702): All equipment, conductors, and conduits associated with optional standby systems shall be clearly identified with drawing notation and physical labels. Label conduit at 10' on center and at junction boxes.

6.8.5.2 Photovoltaic Collectors

1. Provide lightning protection on rooftop installation per DCSM section 6.8.6.
2. Consider direction of roof drainage when using ballasted systems.

6.8.5.3 Engine Generators

1. Generators shall be required for all new buildings that:
 - a. Are 20,000 square feet or larger.
 - b. Have a maximum occupancy of 200 or more people.
 - c. Any building with sensitive or life-safety related equipment such as a research lab or a wood/metal shop.
2. Generators rated 500 KW or less shall be natural gas. Generators rated above 500 KW shall be diesel. Fuel tanks shall not be located underground.
3. Specify a minimum 125 degree rise on the alternator.
4. Specify that engines will meet new source performance standards required by 40 CFR 60.
5. Designer should note in specification that elevation of Blacksburg, Virginia is 2,132 feet.
6. Provide generator with low coolant shutdown.
7. Generator manufacturer shall have a factory authorized full service facility located within 100 miles of generator installed location.

8. All access doors for generator enclosure shall be accessible without the use of a ladder, or provide a catwalk.
9. Use the following noise control systems as appropriate to limit generator airborne noise to a maximum of 70 dB(A) measured at ground level exterior locations 50 feet in any direction from the center of the genset.
10. Roof mounted generators are prohibited.
11. All generators shall be exterior to buildings and come with weatherproof sound attenuated enclosures. Provide visual screening as approved by the VT University Architect.
12. The maximum speed of the engine shall not exceed 1800 rpm.
13. Diesel generators shall come with double wall fuel tanks, with a leak detection system.
14. Provide a remote annunciator at a location in the facility that is readily observable.
15. Multiple unit generator systems are not allowed.
16. The basis of design generator manufacturer shall be Caterpillar.

6.8.5.4 Transfer Switches

1. Transfer switch shall contain bypass isolation switch.
2. Transfer switch shall be open transition type.
3. Switch shall confirm phase synchronization prior to the transition.
4. Where the generator system is a “separately derived system” use 4-pole transfer equipment for three phase, 4-wire systems.

6.8.6 Lightning Protection

1. Lightning Protection System Requirements:
 - a. The most recently adopted edition of NFPA 780 shall be used to evaluate lightning protection systems, and to determine if a system is required. For new facilities, roof replacements, and solar array installations the A/E shall evaluate the building to determine if a lightning protection system is required. A lightning protection system is not required where either:
 - i. Ten times the Annual Threat of Occurrence ($10 \times Nd$) is less than the Tolerable Lightning Frequency (NC), as calculated in the Simplified Risk Assessment (L.5) or
 - ii. The Total Risk (R) is less than the maximum Tolerable Risk (RT), as calculated in the Detailed Risk Assessment, for each type of loss relevant to the structure (L.6).

- b. Provide a note on the project cover sheet or electrical cover sheet specifying the risk factors and specify if a lightning protection system is required. Risk evaluation documentation shall be included in calculations.
- 2. Photovoltaic array installations shall be provided a minimum of a lightning arrester either at the array or at the output of the inverter to protect downstream equipment regardless of the risk factor.
- 3. Lightning Protection System Labeling and Certification:
 - a. Initial certification or re-certification by inspection is required for all lightning protection systems which are installed or modified as part of a construction project. The inspection shall be performed by either:
 - i. UL under the most recent edition of UL 96A: Standard for Installation Requirements for Lightning Protection Systems or
 - ii. A Lightning Protection Institute certified inspector under the appropriate Lightning Protection Institute master certificate inspection.
 - b. The inspection shall certify the final installation to obtain a master label for all elements to include the facility and services entering the facility.
 - c. The installation Contractor shall provide a third party master label inspection to the VT PM prior to project close out. Should the Contractor not be able to obtain a complete master label, the VT PM shall provide the remaining certification at the Contractor's expense prior to issuance of a final Certificate of Use and Occupancy or Building Permit Close Out. These are typically part of UL 96A, Chapter 13. Planning and coordination of inspections shall be conducted during the design phase, and shall be coordinated with the VT PM.
- 4. Conceal all downleads including those at grade level.
- 5. Aluminum components may be used above grade. Copper components must be used below grade.

6.9 ELECTRONIC MONITORING AND CONTROLS

6.9.1 Electrical Power Monitoring

See DCSM section 5.1 for energy efficiency guidelines.

6.9.2 Lighting Control Devices

- 1. Wall mounted occupancy sensors shall be included in small rooms such as individual restrooms, one person offices, and small storage rooms like closets, supply rooms or recycling rooms, and areas of rescue assistance when possible. Dual technology ceiling mounted occupancy sensors shall be

- provided in conference rooms, corridors, and classrooms. Wall switches shall also be provided in conference rooms and classrooms such that lights may be controlled by switches when space is occupied.
2. Coordinate the location of wall mounted occupancy sensors with interior design so furnishings do not block sensors.
 3. Exceptions to the above requirements are spaces where lighting is intended for 24 hour operation and spaces where an automatic shutoff would endanger the safety or security of the room or building occupant.
 4. Adjust time-out settings for occupancy sensors to optimize energy saving, re-lamping cost, and user satisfaction. Utilize the following settings:
 - a. Classrooms, private offices, and restrooms: no more than 10-minute time-out setting.
 - b. Laboratories, shops and other hazardous areas: 2-hour time-out setting.
 - c. Break rooms, storage rooms, copy machine rooms: 5-minute time-out setting.
 - d. Conference rooms: 10-minute time-out setting.
 - e. Corridors, lobbies: 5-minute time-out setting.
 5. Dual level control
 - a. Use dual-level light switching or dimmer control in areas 100 square feet and larger.
 - b. Coordinate manual controls with automatic controls so that the manual control can reduce connected lighting load by at least 50 percent in a reasonably uniform illumination pattern.
 6. In corridors, design un-switched “night lighting” luminaires at the entrance/exit to the corridor and at major corridor intersections. These luminaires may be part of the emergency lighting system. Residence hall corridors shall be un-switched and always on.
 7. In classrooms, do not locate un-switched “night lighting” near projection screens.
 8. In elevator lobbies, design un-switched “night lighting” luminaires at the entrance/exit of the elevator.
 9. In spaces with more than one personnel entrance, design the lighting controls so all required manual control will be available at each entrance.
 10. The basis of design manufacturer for University dimmers and lighting controls shall be Lutron.
 11. For buildings greater than 5,000 square feet, provide means of automatic lighting shutoff for each area.
 12. Provide time switches with astronomic time, automatic daylight savings time changeover, and battery backup.

6.9.2.1 Means of Egress Illumination

Restrooms serving more than one occupant and all occupied rooms and spaces 300 square feet and larger shall be provided with normal power means of egress illumination in accord with the VUSBC.

The means of egress shall be either a fixed means of egress path or the entire floor area of the room or space.

The room or space shall meet minimum normal power illumination levels at all times the space is occupied even with all light controls turned "OFF." This shall not preclude the use of occupancy sensors to determine if the room or space is occupied.

CHAPTER 7 - CONSTRUCTION RELATED ACTIVITY

7.1 PRE-CONSTRUCTION MEETING REQUIREMENTS

The purpose of the pre-construction meeting is to clarify and discuss specifics related to the construction project. Participants in the project shall be clearly identified by their department or organization and their chain of authority.

Pre-construction meeting attendees and departmental discussion items may include the following:

1. UBO
 - a. Required testing and inspections for the project (varies depending upon complexity and type of project)
 - b. Procedures for requesting inspections
 - c. Recommendations for avoiding issues that can slow construction progress
2. SID
 - a. ESC requirements
 - b. SWM requirements
 - c. Stormwater Record Report requirements
 - d. Inspections
 - e. Responsible Land Disturber information
3. OUP
 - a. Mock-up inspection items (see DCSM section 1.7.1)
 - b. Provide submittal log (see DCSM section 1.5). OUP to identify submittals that require review and comment.
 - c. Protocol for historic restoration, salvage, and refurbished (where applicable)
4. CC
 - a. Pay application procedure
 - b. Schedule submission
 - c. Capital Construction Coordination Meeting requirements
 - d. Emergency contacts
 - e. Procedures for shop drawings, and product and sample submittals
 - f. Digital submittal process (RFI, ASI, ESI, etc.)
 - g. Change order process
 - h. Site access procedures
 - i. Job site cleanliness
 - j. Construction Field Representative roles and responsibilities
 - k. Third party inspectors
 - l. Shut down procedures (utility, road, sidewalk, etc.)
 - m. Acceptable campus procedures for personnel etiquette

- n. Parking/eating requirements
- o. Weather delays
- p. Project close-out requirements and procedures
- 5. EHS
 - a. Safety Requirements for Contractors and Subcontractors
 - b. Site access requirements
 - c. Program specific safety coordination
- 6. VTES/Utilities Distribution
 - a. Requirements for A/E review of utility shop drawings
 - b. Location and avoidance of buried utilities (see DCSM section 7.9)
 - c. Department contact if any unmarked utilities are encountered or if any utilities are damaged during construction
 - d. Coordination of utility shutdowns (see DCSM section 7.9)
 - e. Verification that safety training requirements have been met
 - f. Process for escorting construction personnel in substation areas and steam tunnels (see DCSM section 7.9)
 - g. Safety training requirements
- 7. NI&S
 - a. Periodic Field Observations requirement and stages of construction
 - b. Safety standards and expectations from the Contractor for NI&S staff to be onsite

Coordinate project specific pre-construction meeting attendee requirements with the VT PM.

7.2 PRE-INSTALLATION MEETING/INSPECTION REQUIREMENTS

- 1. Stormwater BMP Pre-Installation
- 2. Hokie Stone Installation (see Appendix G: Hokie Stone Masonry Guide Specifications)
- 3. Landscape and hardscape installation (see DCSM section 4.1)
- 4. VTES/Utilities Distribution
 - a. Central utility connection inspections, in addition to the UBO inspections
 - b. Cable splices or cable terminations at transformers

7.3 PROGRESS MEETINGS

Meetings shall be held on a monthly basis (at a minimum) or as the project requires. The following items shall be addressed as part of the meeting:

- 1. Status of project drawings/specifications
- 2. Schedule status

3. Outstanding issues related to key building components or systems
4. Any changes in site limitations or work rules related to the project
5. Project budget status
6. Project savings opportunities

7.4 CONSTRUCTION SAFETY

Contractors shall follow Federal, Commonwealth of Virginia, and VT construction safety requirements and shall bear all responsibility for employees under their control. Contractors shall provide appropriate safety training to employees and/or affirm that employees have received and understand the safety training required for the specific jobsite.

VT construction safety requirements are specified in Virginia Tech's Safety Requirements for Contractors and Subcontractors Program which is located on the EHS Contractor Safety Program website as the Contractor Safety Guide.

7.5 CONSTRUCTION WASTE MANAGEMENT AND DISPOSAL

1. General: Responsible, thoughtful design can greatly reduce the amount of construction waste through the use of standard sizes for construction materials, minimization of applied finishes, and careful considerations for manufacturing methods.
2. Sustainable Considerations: The University's goal is to keep construction waste out of the landfill to the maximum extent practicable by emphasizing reuse and recycling. The diversion of waste materials shall be accomplished through salvage, reuse, and recycling as defined in the project specifications with diversion goals set in keeping with the USGBC's LEED standards and the VT CAC. Certain items may be taken to surplus to be sold by VT, coordinate specific project requirements with the VT PM.
3. Materials to be considered for collection and waste diversion shall include:
 - a. Land-clearing debris
 - b. Clean or Pallet wood
 - c. Plywood, OSB, or Particle Board
 - d. Concrete
 - e. Hokie Stone waste (See Appendix G: Hokie Stone Masonry Guide Specifications)
 - f. CMU or Brick
 - g. Unpainted Gypsum Drywall
 - h. Metals (copper, aluminum, steel, etc.)
 - i. Paint

- j. Carpet
 - k. Acoustical Ceiling Tile
 - l. Cardboard
 - m. Mixed Paper
 - n. Commingled Materials (plastic bottles, glass bottles, aluminum cans, etc.)
 - o. Plastic Containers (#1 through #7)
 - p. Glass
4. Collection Containers: Contractors are responsible for providing and servicing containers for construction waste collection by the Montgomery Regional Solid Waste Authority (MRSWA). Virginia Tech is a jurisdictional member of MRSWA, and cardboard, mixed paper, commingled materials, plastic containers, glass, and metal can be recycled at their materials recovery facility (MRF). Contractors shall work with MRSWA for the disposition of construction materials they can receive, and they must make arrangements for the disposition of the remainder.
 5. Reporting: Per the VT CAC, General Contractors shall maintain a record of all construction material recycled and placed in the local landfill, and provide data to the VT PM for inclusion in the Calendar Year Recycling Rate Report for Virginia Tech. This data is subsequently provided to the MRSWA for inclusion in the regional recycling rate report to the DEQ.
 6. Hazardous waste, fluorescent bulbs and ballasts, and similar waste streams from renovation projects shall be handled as outlined in Virginia Tech's Safety Requirements for Contractors and Subcontractors Program. When practicable, it is recommended that TCLP testing be performed during the planning for the project so that hazardous waste determinations can be made in advance and incorporated into the design.

7.6 CONSTRUCTION SITE FENCING

1. General
 - a. Prior to initiating any on-site construction activities, the General Contractor shall erect a temporary construction fence as indicated in the contract documents. Prior to the start of installation, the contractor shall meet with the University and the A/E to discuss timing, work conditions, and pedestrian routing considering egress for neighboring buildings.
 - b. Coordinate with the Blacksburg Volunteer Fire Department if fenced area contains fire hydrants.
 - c. The contractor shall contact Virginia 811 at 811, 1-800-552-7001, or <http://www.va811.com> before driving any posts for the fencing.

- d. Project signage shall be coordinated and approved by OUP prior to being posted on construction site fencing. Signage not requiring prior approval on construction site fencing includes:
 - i. “No Trespassing” signs may be installed at 50 foot intervals,
 - ii. Safety related signs required by OSHA,
 - iii. Permit related documents as required by the DEQ, SID, and UBO, and
 - iv. Visitor site entry rules as required by the contractor.
 - e. The contractor shall keep plant growth from around the base of the fence by either trimming or chemical treatment.
 - f. Fence shall be maintained for the duration of the project and shall not be removed without the University’s permission.
2. Fence Design and Materials
- a. The minimum height for all temporary fencing shall be 6 feet.
 - b. The fencing shall be of galvanized 11-1/2 gauge chain-link construction with a minimum of 1½" outside diameter tubular steel posts and top rails.
 - c. Surface mounted fence panels may be used with the approval of the University and are to be adequately braced to resist wind and ice loading and shall and shall be continuously connected to prevent access by the public.
 - d. Privacy netting to screen construction activities shall be used on all “core campus” (bounded by Perry Street, Washington Street, West Campus Drive, and Kent/Stanger Streets) projects, or as specified in the contract documents.
 - e. Privacy screen material shall be green polyethylene netting with a weave equal to the basis of design of US Netting’s Windscreen. Barbed wire shall not be used.
 - f. Placement of fencing and privacy screen shall not reduce roadway and crosswalk sight distance below VDOT standards. Reference VDOT I&IM-TE-384.0 (or most recent) for crosswalk details.
3. Gates
- a. Limit entrance/exit to no more than two locations, unless otherwise approved by the University.
 - b. Vehicular gates shall be located only where there are Construction Entrances in place per the DEQ.
 - c. Gates shall be a minimum of 12 feet in width to allow access for emergency vehicles.
 - d. Where other transportation authorities need to review gate locations and operation, communication with those authorities will be coordinated through the University.

- e. Gates shall be closed and locked at all times the site is not occupied, unless otherwise directed by the University where emergency vehicle passage through the site is needed to access existing occupied buildings.
4. Accessible Design
- a. Alternate accessible routes must be provided when construction fencing blocks established ADA paths.
 - b. Signage must be placed at the entrance to the blocked ADA pathway and clearly indicate the alternate accessible route. If the construction fencing blockage is obscured from line-of-sight at the beginning of an ADA pathway, additional signage shall be required to prevent hazards in re-routing of those requiring accessible routes. Coordinate with the VT Office of Equity and Accessibility on placement of signage.

7.7 TEMPORARY FACILITIES, SIGNAGE, AND CONTROLS

1. Any phasing of the limits of disturbance and construction shall be shown clearly. All fence locations and gates shall be indicated for each phase.
2. All transportation routes shall be shown for each construction phase.
3. Construction activities shall not block transportation sight distances. This is especially important at all transportation intersections. Follow VDOT standards for sight distances.
4. Include in the general notes that all vehicle, bike, and transit (road and trail) disruptions shall be coordinated with the VT PM and shall require at least 3-week notice by submission of a detailed and clear plan and submission of a traffic disruption request found at: <https://www.planning.transportation.vt.edu/>
5. Traffic disruptions during VT events such as large home sporting events and commencements shall not be permitted. Exceptions shall be requested at least 6 months in advance, but are typically denied.
6. All delivery routes and site access shall be maintained. This includes mail, vending, delivery, construction traffic, and garbage pickup.
7. All emergency response routes shall be maintained. The appropriate agencies shall be notified of any changes.
8. All transportation routes of completed construction shall be shown.
9. All road work shall require a VDOT permit unless waived by Virginia Tech.
10. Inspections for all road work shall be coordinated through the VT PM but minimum inspections shall be at:
 - a. Subgrade prior to placement of base stone
 - b. Base stone prior to placement of pavement
 - c. Pavement prior to pavement markings

11. Geotechnical testing shall confirm subgrade and pavement design per VDOT standards.
12. If existing pavement is used, pavement structure shall be confirmed during design.

7.7.1 Road Closures and Traffic Disruptions

1. VT Project Manager fills out the Traffic Disruptions Request Form on-line: www.planning.transportation.vt.edu at least 3 weeks before disruptions and contact Parking Services 540-231-3200.
2. The information is circulated to the Traffic Disruption Distribution Email List for comments.
3. Events (non-construction) are then handled by VT Police Department and/or Parking Services
4. Construction related disruptions are announced by:
 - a. Parking Services will send an email to VT Repair and copy the VT Director of Buildings and Grounds and/or
 - b. VT Repair – An email notice will be sent out by VT REPAIR if they deem necessary
 - c. A Campus Notice is recommended for major situations.
5. If a map or sketch is needed the A/E or contractor will produce it along with the MOT (Maintenances Of Traffic) plans.
6. For major road closures the VT Project Manager may need to contact the VDOT Traffic Management Center Salem, so that the information can be available through 511 and other VDOT resources. 888-782-7982 or salemtmc@vdot.virginia.gov
7. Further coordination of the traffic disruption or last minute schedule changes should be done through VT Parking Services and/or VT REPAIR at 540-231-4300. Coordinate with the VT PM.
8. Traffic Disruptions:
 - a. All traffic disruptions shall be coordinated with the VT PM.
 - b. Temporary road or lane closures shall be in compliance with the current version of the Virginia Work Area Protection Manual to ensure clearly defined expectations for vehicle and bicycle operators.
 - c. For temporary total road closures, the Contractor shall supply and set up two variable message boards for a minimum of two weeks prior to the road closure and for a minimum of two weeks during the road closure for a total of a minimum of four weeks. Project specific requirements and placement locations shall be coordinated with OUP through the VT PM.

- d. Projects must maintain the flow of all traffic on and adjacent to the project site including road, trail, sidewalk, ADA routes, etc.
- e. Accommodations for all traffic types (vehicle, bike, pedestrian, etc.) must be made with Virginia Tech Parking Services (540-231-3200) at least three weeks prior to occupation of the site.
- f. Deliveries that cannot be accommodated within the staging area may be briefly off-loaded in the roadway only with prior coordination Virginia Tech Parking Services at least five working days in advanced.

7.7.2 Road Work Process

Any work not inspected by VDOT requires coordination with the UBO.

1. Traffic disruption request form is received, information is distributed, and comments received. Routine VT maintenance does not need a VDOT permit
2. The contractor fills out the VDOT permits, prepares the MOT (Maintenance Of Traffic) Plan, and submits a plan sheet showing the work to be done.
3. Contractor and VT discuss the projects specifications, VDOT permits, VDOT bonding, and MOT plans. If VT approves these, then the contractor takes these to VDOT. VT notifies VDOT of the upcoming work.
4. VDOT has final review of VDOT permits and bonding. Upon VDOT and VT approval work can begin.
5. The contractor shall notify VDOT and VT at the stages of construction depicted in the specifications, but at a minimum, at the following times:
 - a. When ditch (or subgrade) is ready for backfill
 - b. During backfill and compaction
 - c. Just before asphalt, fine grading
 - d. During paving
 - e. After pavement markings and signs are installed
6. The contractor should contact VT and VDOT 36 to 48 hours before each of the phases above for inspection.
7. When project is complete to the satisfaction of VT and VDOT, then VDOT can release the bonds.

7.7.3 Road Work Specifications

See the asphalt pavement repair detail in the VT Design Standard Detail Library.

1. Any drainage problems should be corrected before or during backfill with under-drains.

2. Trench Backfill
 - a. VDOT #57 stone around utility and only to the top of utility, not any higher.
 - b. Above the VDOT #57 stone there are 2 options:
 - i. Flowable Fill at 100 psi (can go up to below BM-25.0)
 - ii. Stone backfill is VDOT stone 21B at 95% compaction in 6 inch lifts.
3. At elevation 18 inch below final asphalt (top of SM-9.5A) create 12-inch bench on each side of trench.
 - a. Backfill with 8 inch of VDOT stone 21B at 95% compaction.
 - b. Then 8 inch of BM-25.0 – at 2 lifts of 4 inch each.
4. For Surface Mix (SM-9.5A) mill back 5 feet on each side of trench; SM-9.5A at 165 lb./sq. yd.

7.7.4 Traffic Gates

Installation or removal of traffic barricade gates shall be coordinated through the VT PM with NI&S, Engineering Operations, and the Virginia Tech Office of Parking and Transportation.

7.7.5 Temporary Project Signage

Signage shall be provided to guide pedestrians along general and accessible routes necessary to navigate obstructions caused by project sites. Data and visual communication materials on boundaries of site fencing and other impacts shall also be provided to the Facilities Department. Project managers shall coordinate aggregation and submission of necessary communication materials.

1. All exterior signage that is intended for traffic control shall meet VDOT Standards and follow Virginia Tech Parking and Transportation Master Plan.
2. All signs related to transportation are to be approved by OUP.
3. All exterior signage shall follow the Appendix F: Campus Wayfinding Guidelines for materials standards and mounting methods and where applicable.
4. Construction Entrances shall have at least two 24" × 24" safety orange diagonal signs (one for each direction) stating "CONSTRUCTION ENTRANCE AHEAD," as shown following (left). The project name shall be placed below the Construction Entrance sign.



5. ADA parking signs shall be as shown above (right).
6. All permanent parking signage shall be purchased by the project through the Virginia Tech Sign Shop.

7.7.6 Temporary Barriers and Enclosures

The OUP shall be consulted on the screening requirements for construction sites prior to bidding of projects, finalization of guaranteed maximum prices, or design-build contracts.

7.7.7 Temporary Facilities

Though funding for the modular or industrialized building or prefabricated building may be proposed from maintenance and operating funds, such projects are essentially Capital in nature. Prior to submitting a requisition for purchasing or before finalizing any contractual arrangements for lease of a temporary facility, submit plans of the structure to the UBO for issuance of a building permit. The plans shall show that the structure meets the requirements of the VUSBC or the Virginia Industrialized Building Safety Regulations and Virginia Manufactured Home Safety Regulations and meets accessibility requirements. The plans shall include site location plan, proper anchorage, tie down and utilities for the structure.

Include a site plan indicating the proposed location of the facility. The location of the facility and the aesthetics of the proposed structure shall be presented to the AARB. Prior to occupancy, the VT PM shall apply to the UBO for a Certificate of Occupancy for the facility. Form HECO-13.3A shall be completed and be accompanied by a letter report of inspection recommending occupancy of the facility from the regional SFMO.

7.8 TEMPORARY PARKING/STAGING AREAS

7.8.1 Access

Contractor to develop and submit to the VT PM an access plan to address the following impacts:

1. No vehicles shall obstruct ADA access aisles, park on walkways, or park on landscape/green spaces.
2. Bike lanes shall be maintained. Alterations shall have proper signage.
3. All transit stops and routes shall be maintained.
4. All pedestrian routes shall be maintained.

7.8.2 Contractor Parking

Parking on the Virginia Tech campus is regulated for all vehicles. Virginia Tech Parking Services strictly enforce parking regulations that are posted at www.parking.vt.edu. Violations of parking regulations may result in parking tickets, wheel booting, or vehicle towing. Contractor parking on campus is managed with the following requirements:

1. Parking within the construction fencing of a capital project is allowed without restriction. Company and private vehicles may be parked inside the fence without a permit. All efforts shall be made to keep contractor parking within the fenced area. Parking onsite after the project is deemed substantially complete and the construction fence is removed requires written approval by the University and/or an appropriate parking (turf) permit.
2. Prior coordination with Parking Services (540-231-3200) is required shall the need arise for additional contractor parking. The University will designate a parking lot on campus for use by contractors. The designated contractor lot will be the only lot on campus in which contractor parking is allowed. The University, at its discretion, reserves the right to change the designated contractor lot to any other lot on campus during the term of the contract. Parking in the designated contractor lot requires the purchase of a vendor/business/contractor permit from Parking Services for both company and privately owned vehicles. These rates may change on an annual basis at the discretion of Parking Services.
3. The hours of use of the designated contractor lot are generally reserved for normal daytime hours of work (7 am to 5 pm, Monday-Friday). The potential need for occasional night work is recognized and accepted, providing the lot is not used for overnight storage of vehicles. At no time will the lot be used

to store equipment or industrial vehicles. Also, there will be occasions, typically on weekends, when the lot must be completely vacated for special activities such as graduation or football game parking. Parking Services will inform the CC department in advance of the special events dates and notices will be posted at the entrance to the lot. Vehicles left in the lot on these occasions are subject to being towed at the violator's expense.

4. Contractors shall abide by all traffic regulations at Virginia Tech. Construction sites must make consideration for the flow of pedestrian traffic around the site. Coordination for vehicle and pedestrian traffic must be made with the Office of Transportation (540-231-7641) prior to occupation of the site. Large deliveries that cannot be accommodated within the staging area may be briefly off-loaded in the roadway only with prior coordination with the Virginia Tech Police Department (540-231-6411) at least five working days in advance. No significant activities shall be planned at the construction site during home football games or University graduations.
5. The contract shall include the contractor parking statement.
6. An automated access gate shall be considered when controlling access.

7.8.3 Staging Areas

Contractor/material staging areas must be approved by the University and clearly delineated in the construction documents.

7.9 SITE PREPARATION

7.9.1 Utilities

1. Contact Virginia 811 no less than three business days in advance of any excavation, digging, etc. Do not disrupt the soil prior to the processing and approval of the dig ticket. It is the responsibility of the party doing the excavation to contact Virginia 811.
2. VTES or Utilities Distribution need to coordinate any utility shutdowns. Scheduled outages shall require a minimum advance notice of one week. Overtime charges may apply for outage related activities that take place outside of normal working hours.
3. VTES must escort contractor personnel in steam tunnels, substation areas, and in high voltage switch rooms in buildings. These activities shall be planned to take place during normal working hours. Contractors shall complete any required safety training in advance of the visit through their own sources and provide verification of training to Facilities Safety.

7.9.2 Tree and Plant Protection

1. Include the tree protection detail located in the VT Design Standard Detail Library in the drawing package as the required tree protection.
2. Tree protection fencing must be installed around existing trees noted to remain on plans within the fenced area. Fencing shall extend a distance from the trunk of $1\frac{1}{4}$ feet per each inch of trunk diameter or 6 feet, whichever is greater. For example, a tree with a 12-inch trunk diameter shall be fenced 15 feet from the trunk (30-foot diameter).
3. Fencing must be installed prior to any equipment arrival on the site. Work may not begin until fencing is installed.
4. Fencing shall be galvanized chain link, 4-foot minimum height. Plastic fencing and wood stakes/T-posts, or snow fencing are not acceptable.
5. Fence shall be maintained for the duration of the project and shall not be removed without the University's permission.
6. No material storage, vehicles, or any other activity shall occur at any time within tree protection fencing. Coordinate with VT PM if any landscape maintenance is required while the tree protection is installed.
7. Contractor may be required to pay for tree replacement and/or soil compaction remediation costs if there is any incursion into tree protection zones.

7.9.3 Site Clearing and Building Removal

Project teams shall consult OUP and SID. The intent is to ensure proper protection and care of existing elements identified for salvage. Ensure protection of adjacent elements to remain after demolition. Sufficiently prepare for new construction elements on and around selective demolition. See DCSM section 1.7.5 for demolition of building requirements.

7.9.4 Dust, Mud, and Dirt Control

Contractor is required to maintain compliance with the VTAS&S.

7.9.5 Earthwork Specifications

Specifications shall be definite, not general.

1. Coordinate specifications with the drawings.
2. Include a geotechnical/soils report in the project manual and a disclaimer stating that the report is not part of the contract documents each time this report is referenced.

3. Specifications for materials and instructions shall state whether they are included in the base bid or will be an extra cost item.
4. Rock excavation shall be included in the base bid to the extent that locations are sufficiently identified in the geotechnical/soils report. See DCSM section 7.9.6.
5. Earthwork specifications shall include soil and aggregate material definitions for all materials used in the project. The soil materials shall be defined by a recognized soil classification system, such as the Unified Soil Classification System or the AASHTO Soil Classification System.

The definitions below are by the Unified system. The aggregates shall include gradations required for each material. All A/E standard specifications shall be edited to conform to the following requirements.

1. Structural Fill and Backfill: Generally restricted to GW, GP, GM, SM, SW, and SP unless other materials are specifically approved by the soils engineer or firm that conducted the on-site soils evaluations. SC, CL, and ML might be considered in some situations with the approval of the soils engineer.
2. General Fill and Backfill: Includes all classifications of materials noted above.
3. Unsuitable Materials: Includes OL, MH, CH, OH, and PT, saturated material which in the judgment of the soils engineer cannot be aerated to be made acceptable, uncompacted fill (for structural bearing conditions), fill with unacceptable quantities of non-soil products, or other materials judged unsuitable by the soils engineer.
4. Aggregates: They may include porous backfill, pipe bedding, underslab fill, any special blend or open-graded material required for a special bearing or drainage use.
5. Moisture Content of Soil Materials: Laboratory tests are generally conducted on samples to determine the maximum density of soils, usually achieved at optimum moisture content. Field conditions during construction prevent attaining and maintaining the optimum moisture content. This requires that a tolerance for departure from this optimum must be specified. This tolerance is generally specified in the range of plus or minus 3% to 5% from the optimum moisture content without significantly affecting the ability to achieve the specified density.
6. Quality Assurance and Testing: The specifications shall list the tests required to be performed on the work (e.g., ASTM, AASHTO, VDOT, or other test procedures) and stipulate the values to be achieved.

7.9.6 Rock Excavation

Where rock excavation is likely to be encountered, the site shall have an adequate number of borings taken. The designer shall use this data to show on the plans enough assumed rock profiles over the entire area to be excavated to identify clearly the condition assumed for the base bid. The specifications shall state the method of volume calculation and pay lines to be used.

The designer shall calculate and state in the Bid Form (see example in VT CPSM) an estimated quantity of rock to be excavated based on the assumed rock profiles. The bidder shall indicate a unit cost by which his bid for the rock excavation is calculated. This bid item shall be added to the other bid items to establish the Lump Sum Bid. The final net contract payment for rock excavation shall be adjusted (plus or minus) based on the actual quantity of rock excavated. This price shall include disposal of excess. General rock pay width shall be based on 18" outside of a neat wall face; or vertical projection from the extremities of the base, whichever is greater. Trench rock quantity shall be based on the widths stated in the specifications.

Rock excavation shall be defined as hard bed rock, boulders or similar material requiring the use of rock drills and/or explosives for removal. The criteria for classification of general excavation as rock shall be that material which cannot be removed by a track mounted D-8 dozer with a heavy ripper or 3/4 CY track mounted shovel with appropriate scoop. The criteria for trench rock shall be that material which cannot be removed by a 3/4 CY track mounted backhoe with a proper width bucket. The trench unit price shall only apply to material below the general grading level.

When the overburden is removed and the rock surface is exposed, the A/E shall verify that the material is of a hardness which qualifies it for classification as rock excavation. Actual profiles shall then be taken. The net difference between the actual rock excavation and that estimated volume shown in the proposal shall be applied times the contract unit price for adjustment of the final payment.

All rock quantities shall be based on in-place volumes and shall be obtained by means of the method of average end areas or other method acceptable to the engineer. Truck counts will not be accepted as a method of determining earthwork quantities.

CHAPTER 8 - INSPECTIONS AND OCCUPANCY

Inspections are performed by the UBO and CFR or designees as approved by the VT PM. Inspections performed by the office of the UBO include, but are not limited to, code inspections of the foundation, structural members, and all mechanical, electrical, and plumbing systems prior to concealment, substantial completion and final inspections, and special inspections (see DCSM sections 1.7.2.4.2 and 8.2).

CFR duties begin during the pre-construction phase and continue to the final inspections of work products. CFR responsibilities include the frequent or periodic monitoring of materials, workmanship, records, and tests during the construction process and final inspections of the completed work product. A list of services required from the CFR is listed in DCSM section 8.1.4.

8.1 CONSTRUCTION FIELD REPRESENTATIVE INSPECTIONS

Except as provided in DCSM section 8.1.1, the VT PM shall designate a specific individual to serve as CFR on every project whenever work on the project is in progress. The name of the CFR shall be shown on the form HECO-8. Where completion of a HECO-8 is not required, the name of the CFR will be entered in the project file. The CFR shall be knowledgeable of and have reasonably convenient access to the codes and standards referenced in the Contract Documents which stipulate the requirements for installation and workmanship on the trades involved in the Work (ACI, SMACNA, NFPA, NEC, ICC, ASHRAE, etc.). See DCSM section 8.1.3 for minimum qualifications of the CFR. These inspections do not nullify or otherwise replace inspections required by, and performed by, UBO staff as described in the DCSM.

8.1.1 Small Projects

For small or simple trade contract projects, a member of the University may serve as the CFR. The VT PM may designate a CFR for projects accomplished using in-house forces. The duties of the CFR will be consistent with the size and complexity of the job and similar to those listed in the following paragraphs.

8.1.2 Use of Facilities

The firm, individual or University staff providing these inspection services shall furnish all labor, materials, and resources for full-time CFR services during the construction of the project. The CFR shall be a duly authorized and qualified person who shall be available during the entire time work is in progress on the site.

The A/E shall provide the CFR with a copy of all approved shop drawings, submittals, samples, schedules, change orders, clarifications, supplemental information, and other pertinent correspondence and material for the CFR's use at the jobsite.

8.1.3 Minimum Qualifications of the CFR

The CFR shall meet the DCSM section 1.7.2.4.1 criteria and the Qualifications of Inspectors and Testing Technicians on the [VT Facilities Forms](#) web page. The CFR also shall have the following minimum qualifications:

1. Have education, trade related training, and experience in a design or construction related field;
2. Have some knowledge of construction means, methods and procedures;
3. Be knowledgeable of and have reasonably convenient access to the codes and standards referenced in the Contract Documents which stipulate the requirements for installation and workmanship on the trades involved in the Work (ACI, SMACNA, NFPA, NEC, ICC, ASHRAE, etc.);
4. Have an understanding of the General Conditions of the Construction Contract;
5. Have the ability to read and understand the requirements of building Plans and Specifications;
6. Have the ability to read and understand a construction bar chart schedule; and
7. Have the ability to communicate effectively orally and in writing.

8.1.4 Duties of the CFR/Clerk of the Works

The following is a detailed listing of the duties, services, functions and responsibilities of the CFR for Capital Outlay Projects. This listing supplements and expands upon the duties, functions and responsibilities generally described in section 16 of the General Conditions of the Construction Contract. The CFR is an employee of the University and is responsible to the University for performing the duties, observations, and services described. This in no way relieves the A/E from providing and being responsible for his contractual obligations as described in the VT CPSM and the DCSM, the A/E contract, and the General Conditions of the Construction Contract, form CO-7. Administrative duties may be assigned to/performed by a Clerk of the Works in support of the CFR.

The CFR shall perform the following services unless modified by the contract for services:

1. Monitor and inspect all construction materials, equipment, and supplies for compliance with the contract documents, shop drawings, and submittals.
2. Inspect installation and workmanship for compliance with the approved plans, specifications, shop drawings and referenced standards (ACI, SMACNA, NFPA, NEC, BOCA, ASHRAE, etc.). Verify compliance prior to cover or close-in of work.
3. Monitor quality and coordination of trade contractor work at all times. Recommend to the VT PM ways to alleviate identified problems. Identify all work not done in accord with the contract documents and report it to the VT PM and the A/E.
4. Immediately report all discrepancies in the Contractor's work to the A/E and the VT PM. Also report any discrepancies noted in plans and specifications to the A/E for clarification or resolution. The CFR shall not interpret or change approved plans and specifications.
5. Keep a record or records, including a daily log of construction activity, roofing, tests, inspections, reports, photographs, and annotated drawings, in order to show the progress of and changes in the project during its construction. Keep records of the designer's and designer's representatives' site visits. Maintain these records.
6. Provide full-time inspection of the roof during its application. The CFR shall not permit the Contractor to install roofing materials without first having obtained from the A/E a copy of the manufacturer's certification confirming that roofing materials delivered for use on the project meet specified ASTM standards. During roofing operations, the CFR shall maintain a daily written roofing report covering such items as: weather conditions, deck conditions, materials stored, and installation procedures including, bitumen temperature at kettle and point of application, etc. A copy of the daily report shall be given to the Contractor.
7. Notify the A/E and the VT PM if work begins before required shop drawings, product submittals, or samples have been approved by the A/E. Receive and log samples required to be furnished at the site; notify the A/E when they are ready for examination; record the A/E's approval or other action; and maintain custody of approved samples.
8. Report to the A/E and the VT PM when in the CFR's judgment the work being performed does not conform to the requirements of the contract documents or safety requirements are not being followed and, if appropriate, recommend suspension of the work.

9. Notify the VT PM of any safety violations, OSHA visits, accident reports, and corrective actions observed. Such reports do not relieve the Contractor of responsibility for safety under terms of the contract for construction.
10. Observe tests required by the contract documents. Record and report, to the A/E and VT PM, the Contractor's test procedures and, where applicable, results of the tests.
11. Observe and report on all tests performed by the Contractor and note results in daily reports.
12. Report presence of and activities performed by University's testing and inspection agents.
13. Verify invoices for on-site tests/site visits of independent testing entities, which are to be paid by the University.
14. Submit to the VT PM and the A/E a weekly report in an approved format summarizing the significant activities and occurrences at the project site. Include copies of the daily reports with the report.
15. The CFR shall record, maintain, and submit with the weekly report a running record of outstanding, unresolved issues. The record shall include the issue, date of occurrence, and date of resolution. After an item is reported to be corrected, it shall be deleted from the list in the weekly report.
16. The CFR shall report, in writing, to the VT PM and A/E any notifications from the Contractor of dates and times that services will be disrupted.
17. The CFR shall participate in progress and monthly pay meetings with the VT PM, the A/E, the Contractor, and other designated representatives, to review the current status of work and any action needed to keep the project within budget and on schedule. The VT PM may assign the CFR other duties related to these scheduled meetings.
18. The CFR shall record, maintain, and submit with the weekly report a running record of outstanding discrepancies/deficiencies noted by the CFR. The record shall include the item, the date observed, and the date corrected. After an item is reported to be corrected, it shall be deleted from the list in the weekly report.
19. The CFR shall maintain, on site, a complete set of minutes of meetings as a running record of evolution of problems and solutions during progress of the work.
20. The CFR shall maintain current copies of the following at the jobsite:
 - a. current set of contract documents (addenda, contracts, drawings, specifications, change orders, proposed change orders, request for clarification, construction change authorizations, A/E's supplemental instructions, etc.)

- b. all correspondence and reports of site conferences
 - c. shop drawings
 - d. samples and product data
 - e. University's purchases, including material and equipment
 - f. supplementary drawings
 - g. color boards, schedules and samples
 - h. names and addresses of Contractors, subcontractors, and principal material suppliers
 - i. Contractor's applications for payment
 - j. running list of discrepancies/deficiencies and dates
 - k. running list of unresolved issues
 - l. A/E punch lists with date of issue indicated on each
 - m. any other documents and revisions resulting from issues concerning the contract or work
 - n. maintenance and operating manuals and instructions when received from Contractor
21. The CFR shall review and provide a recommendation to the VT PM on the acceptability of all proposals submitted by the Contractor for changes initiated by the VT PM or A/E, and the acceptability of all claims for change orders initiated by the Contractor.
 22. The CFR shall confirm to the VT PM that changes required by approved change orders are incorporated in the work at a time deemed appropriate by the Contractor, and are reflected in the Contractor's progress schedule.
 23. The CFR shall keep a record of all Proposal Requests from the A/E, change order proposals from the Contractor, and executed change orders from the A/E. He shall file copies with the VT PM monthly.
 24. Throughout construction, the CFR shall review the Contractor's detailed schedule and advise the VT PM on the Contractor's progress and all other construction scheduling issues. He shall monitor the schedule, notify the VT PM of any slippage in critical path time, make recommendations on accepting the Contractor's proposed schedule recovery plan, and maintain an annotated copy of the schedule that reflects actual progress of the work.
 25. The CFR shall maintain, at the site, a copy of the project schedule with notations, highlighting, etc., that show work to date and any changes made in the critical path method (CPM) schedule. Where a schedule shows early/late start and finish dates for various activities, the CFR shall note actual dates of each occurrence on a copy of the CPM listing. The CFR shall make recommendations to the VT PM as appropriate concerning the Contractor's conformance to the schedule and/or recovery plans.

26. When the Contractor is directed to make changes based on unit costs, the CFR shall verify accuracy of quantities of material and labor (or other units of measure) attributable to change orders. The CFR shall verify that all change orders are complete. The CFR shall observe the Contractor's record drawings at intervals appropriate to the state of construction and shall notify the A/E and the VT PM of any apparent failure by the Contractor to maintain up-to-date records.
27. The CFR shall review each certificate and application for payment. He shall advise the A/E and VT PM whether they accurately represent progress of the work and values of each line item in the schedule of values. He shall verify that stated quantities of stored materials are accurate. Based on such review and verification, he shall make recommendations to the VT PM and A/E to approve or to revise the certificate and application for payment.
28. The VT PM may assign the CFR other duties related to the project.
29. The CFR has no authority to and shall not:
 - a. Authorize deviations from the contract documents;
 - b. Enter into areas of responsibility of the Contractor's superintendent;
 - c. Issue directions regarding construction means, methods, techniques, sequences or procedures, or safety precautions and programs in connection with the work;
 - d. Authorize or suggest that the University occupy the project in whole or in part; or
 - e. Issue a certificate for payment.
30. The CFR shall report to the VT PM.

8.2 UBO SPECIAL INSPECTIONS

8.2.1 General

The VCC Special Inspections and Tests section requires special inspections to be performed on a project and cites requirements for special inspections. These inspections have been, heretofore, provided on state projects by a combination of the University's Project Inspection, the A/E and the University's independent testing lab. DCSM section 8.2.2 describes the procedures assuring that the structural, special and other associated inspections are provided for the project.

The concept of the process is that:

1. The A/E will determine in the design the materials, strengths, configurations, quality and standards applicable to the work and describe that information to the Contractor in drawings and specifications;

2. The A/E will specify the submittals (e.g., shop drawings, manufacturer's data, and certificates of conformance), required from the Contractor and review the submittals;
3. The A/E and the VT PM shall review the list of special inspections for the applicable code edition, make appropriate notations on the list and forward the marked-up list with the completed Statement of Special Inspections (HECO-6A) to UBO for review and approval;
4. The Contractor shall review the submittals from its subcontractors, suppliers, fabricators and vendors to assure conformance with the contract documents and assure that materials, sizes, and configurations proposed are compatible with other trades and the space provided;
5. The fabricator, supplier, vendor or production plant shall secure and/or have ongoing the required testing and quality control/assurances program to meet the requirements specified and shall submit certificates of conformance to the applicable standards of practice and quality assurance;
6. The A/E will perform on-site observations of erections, placements, and installations to ascertain the intent of the contract documents and shop drawings are met;
7. The University's CFR/Clerk of the Works will observe day-to-day operations and report deviations/discrepancies in the materials and/or work versus contract documents and approved submittals;
8. The University's test lab will, for the indicated items, make on-site inspections, measurements, tests and sample collections, make applicable laboratory tests and submit copies of the reports to the University, the Contractor, the A/E and the CFR; and the Contractor will have other tests made as specified and as necessary to assure conformance with the applicable regulations and standards of practice and workmanship;
9. The A/E's Structural Engineer, the University's CFR and the VT PM or responsible person shall complete the HECO-13.1B and submit to UBO as soon as completed but prior to the substantial completion inspection report.

8.2.2 Structural and Special Inspection Forms

Structural and special inspection forms are available for download from the [VT Facilities Forms](#) web page.

HECO-6	Schedule of Special Inspections
HECO-6A	Statement of Special Inspections
HECO-6C	Quality Assurance Plan
HECO-6D	Interim Report of Special Inspections
HECO-6E	Statement of Contractor's Responsibility
HECO-6F	Fabricator's Certificate of Compliance

8.3 UNIVERSITY ROOFING INSPECTION

The University shall have a full-time inspector on site while the roof is being applied. The inspector may be the CFR or someone qualified to inspect a roof installation. See qualifications for a roof inspector and roof consultant in DCSM sections 8.3.4 and 8.3.5.

8.3.1 Daily Report

The roofing inspector shall check all materials and application procedures and prepare a daily written report covering such items as: the weather conditions, the deck conditions, the materials stored, the materials installed, and the installation procedures used (including bitumen temperature at kettle and point of applications, etc.). A copy of the daily report shall be given to the contractor, A/E, and the VT PM in a timely manner. The inspector shall not permit installation of roofing materials without having first obtained from the design A/E a copy of the approved shop drawings showing the ASTM or other standards.

8.3.2 Pre-Final Inspection Survey

Comply with the following survey provisions:

1. The A/E shall notify the VT PM, the Contractor, and the roofing contractor (in writing) that he has inspected the roof(s) and finds it (them) sufficiently complete to permit a roofing survey. In no case shall the survey be made earlier than forty days before the substantial completion inspection.
2. The VT PM shall engage the services of an experienced, independent roof survey inspection service or laboratory to survey the roof(s). The service shall use infrared, nuclear moisture detection, or electronic leak detection methods. Roof probes or cuts shall not void the Contractor's two-year guarantee and the manufacturer's warranty/guarantee.
3. The roofing contractor shall cooperate and assist the inspection service by making and repairing any required cores, test cuts, or probes in such a way that the manufacturer's and the Contractor's warranty/guarantees are not voided.
4. A copy of the survey report shall be delivered to the UBO no later than ten days before the substantial completion inspection. Also, copies of all survey reports shall be delivered to the VT PM, A/E, Contractor, and roofing contractor.

5. The University shall pay for the service unless the survey shows roofing deficiencies caused by improper materials, poor workmanship, or Contractor negligence. In that case, the Contractor, at his expense, shall repair or replace the roof(s) and provide additional surveys until the roofing work complies with the contract documents. All corrective work shall be completed before the final inspection.
6. Acceptance of the roofing system shall be contingent on a roofing survey report that indicates the presence of no detrimental amount of moisture (moisture that would cause a significant lowering of the thermal resistance of the roof, separation of the roofing plies, blisters, etc.). Insulation or roofing materials determined in the roof survey to have detrimental amounts of moisture by the Consultant and any materials covering the insulation shall be replaced by the Contractor at no cost to the University.
7. In any case where the roofing survey reports insulation that has lost more than 20% of its dry thermal resistance (R-value), the insulation and any materials covering the insulation shall be replaced by the Contractor at no cost to the University.

8.3.3 Final Inspection

The following items must be given to the University's representative at the Final Inspection:

1. A copy of the General Contractor's and roofing contractor's two-year guarantee.
2. A copy of the roofing manufacturer's standard warranty/guarantee.

8.3.3.1 One Year Inspection

Representatives of the University (and the A/E), the Contractor, the roofing subcontractor, and the membrane manufacturer shall inspect the roof(s) between nine months and one year before the closing of the Contractor's one-year guarantee.

8.3.3.2 Two Year Inspection

The University shall also have the roof inspected at least three months before the two-year guarantee expires and notify the Contractor in writing of any defects noted. The University shall require that any defects be corrected at least 30 days prior to expiration of the guarantee.

8.3.4 The Roof Inspector

The minimum qualifications below serve as criteria for the University's selection of the roofing inspector.

1. The Inspector should have a thorough knowledge of roofing details, flashing, and systems employing single-ply, built-up, metal, shingle, slate, or other membranes as the main weatherproof barrier.
2. The Inspector shall have attended roofing related education in formal schools or seminars sponsored by agencies such as AIA, BURSI, RCI, Inc., CSI, NRCA, or roofing manufacturer's training courses, and shall obtain a minimum of twelve continuing education units annually in such courses, or shall have a current Registered Roof Observer Registration from RCI, Inc. Inspectors with other training must submit qualifications and be approved by the VT PM in advance.
3. The Inspector shall be thoroughly familiar with the latest edition of the NRCA Roofing Manual and specialized manuals prepared by NRCA.
4. The Inspector shall have a minimum of five years of full-time, practical roofing experience or approved equivalent experience.
5. The Inspector shall identify, in writing, at least three projects where he has been the full-time roofing inspector. He should provide names, addresses, and telephone numbers of roof owners and A/E for the roof projects.
6. The Inspector shall be trained and competent in the services he is providing
7. Roof Inspector's Scope of Work:
 - a. The Inspector shall monitor the work for compliance with the contract documents
 - b. The Inspector shall continuously monitor and observe the work at the point of application during installation of the roof.
 - c. The Inspector shall immediately report any deficiencies or deviations to the A/E and the VT PM. A written report shall follow an oral report within two business days.
 - d. The Inspector may recommend suspension of work or rejection of non-complying work to the A/E and the VT PM.
 - e. The Inspector shall not:
 - i. Authorize deviations from the contract documents.
 - ii. Enter the area of responsibility of the Contractor's superintendent.
 - iii. Issue orders on any aspect of construction means, methods, techniques, sequences, procedures, or safety in connection with the work.

- f. The Inspector shall:
 - i. Keep a daily log for each project.
 - ii. Provide a copy of the log to the roofing contractor, the A/E, and the VT PM.
 - iii. Record all pertinent information such as weather, daily progress, workmen on the job, material storage, deck condition, bitumen temperature, installation procedures, quality of workmanship, job-related visitors, and so forth.

8.3.5 The Roof Consultant/Inspection Services Provider

The Consultant shall have the following qualifications:

1. Roof consulting and testing services should be the Consultant's full-time occupation.
2. The Consultant shall have a minimum of five years of field experience in providing the service.
3. The Consultant shall have completed at least three service contracts in the recent past. Work for each of the completed contracts should be roughly equivalent in size and complexity to the proposed work.
4. The Consultant shall be required to submit three complete surveys of roofs that were repaired, recovered or replaced. The survey shall include names, addresses and telephone numbers of roof owners and A/Es responsible for preparing the drawings and specifications.
5. The Consultant shall have attended roofing related education in formal schools or seminars sponsored by agencies such as AIA, BURSI, RCI, Inc., CSI, NRCA, or roofing manufacturer's training courses and shall obtain a minimum of twelve continuing education units annually, or shall have a current Registered Roof Consultant Registration from RCI, Inc. Consultants with other training must submit qualifications and be approved by the University in advance.
6. The Consultant should be trained, experienced, and competent in performing required services.
7. If testing is required, the Consultant shall be appropriately trained, certified, and licensed in the testing procedures (infrared, nuclear, electronic leak detection, core sampling, ASTM procedures, gravimetric analysis, etc.) required for the service.
8. The Consultant should submit documented experience of the firm and resumes of all participating employees.

9. The Consultant's resume should describe other related services and contributions, such as writing, lecturing, and serving as an expert witness. The Consultant should list professional qualifications or licenses.
10. The completed resume form must be submitted with the roof Consultant's response to the University's request for proposal. It will be used with other required items to evaluate the applicant.

8.3.6 Semi-Annual University Inspections

The University shall inspect the roof(s) semi-annually, as a condition of the roofing guarantee. The University shall also inspect the roof(s) before the two-year guarantee expires.

8.4 START-UP/ACCEPTANCE OF MECHANICAL AND ELECTRICAL SYSTEMS

It shall be the A/E's responsibility to verify that the Contractor has all systems functioning properly per design intent; that equipment has been received per Shop Drawings previously approved by the A/E; that all system components have been adjusted and a record made of final settings; and that manual and automatic operating modes have been established for full load ranges prior to notifying the University that the system is ready for final start-up and acceptance testing.

It is the intent that when the startup inspection team is called together to conduct final inspections and acceptance test that the work be started as scheduled and completed without exceptional delay.

Major or time-consuming adjustments or modifications during final inspection shall be avoided. Final inspections requested when the systems are obviously not ready for such testing and inspections may result in a back-charge to the A/E or Contractor for the costs of inspection team visits and related costs. Applicable portions of the above requirements shall be included in the project specifications.

8.5 SUBSTANTIAL COMPLETION INSPECTIONS

A Substantial Completion Inspection is required for all projects. When the Contractor determines that the work, or a designated phase or portion thereof, will be substantially complete and ready for testing and inspection, he shall complete and send form HECO-13.2A with a list of the work he knows to be unfinished or defective to the A/E at least 10 days prior to the date he has set for substantial completion. The A/E will forward the HECO-13.2A to the VT PM and the UBO and attach a written endorsement, based on his periodic inspections, as to whether or not he concurs that the project, or phase, should be substantially complete on the date set by the Contractor. The A/E will then coordinate and arrange a date on or

shortly after the date set by the Contractor for the substantial completion inspection to be conducted.

Participants in the substantial completion inspection shall include representatives of the Contractor, including those of the mechanical, electrical, and major equipment subcontractors, the A/E, the VT PM, the UBO, the SFMO, and other University representatives as designated by the VT PM. The A/E shall conduct and document the inspection and compile a written list of the work or deficiencies noted (punch list) which need to be completed or corrected.

If the A/E, the SFMO, and the University representatives agree that this project, or this portion of the project being inspected, is substantially complete in accordance with the contract documents, the A/E shall execute the appropriate HECO-13.1A, and submit them to the University. Attach copies of the punch list, the Contractor's HECO-13.2A, the HECO-13.3A, and other documents as appropriate.

If one or more re-inspections of the work that the Contractor declared to be Substantially Complete are required because the work was not substantially complete as stated, the Contractor shall reimburse the University for the costs of the re-inspections. The UBO will not accept the project as Substantially Complete unless the facility (part or whole) is ready for occupancy.

8.6 FINAL COMPLETION INSPECTION

When the Contractor determines that the items listed in the "punch list" have been completed and that the work is complete and ready for final testing and inspection, he shall complete form HECO-13.2 and send it to the A/E at least five days prior to the date the Contractor has set for the work to be ready for Final Inspection. The A/E will forward the HECO-13.2 to the VT PM and attach a written endorsement, based on his periodic inspections, as to whether or not he concurs with the date set by the Contractor.

The A/E shall receive the HECO-13.2, the CO-13, written guarantees, equipment and operating manuals and related documents assembled by the Contractor, review same and turn them over to the VT PM at the final inspection. The A/E shall record any items noted for completion or correction. He shall promptly follow up on the items and notify the VT PM, in writing, when they are completed.

The A/E shall conduct the final inspection. A representative of the SFMO either will be present at the inspection or otherwise inspect the completed work and advise the VT PM and the UBO whether the work meets the fire safety requirements of the applicable building code.

The University may have other persons participate in the inspection. If one or more re-inspections are required because the work purported to be complete is not complete, the Contractor shall reimburse the University for all re-inspection costs.

If the A/E and the SFMO representative agree that the building is complete in accordance with the contract documents, and safe to occupy, the A/E shall execute the HECO-13.1 and deliver it, along with the Record Drawings and all other required material, to the VT PM for final acceptance of the project.

8.7 GUARANTEE PERIOD INSPECTION

Prior to the expiration date of the Contractor's one-year guarantee period, but not before nine months of this period has elapsed, the University shall make an inspection of the building, equipment, and/or any other work included in the original Contract to determine whether any defects in materials or workmanship have developed. The University and A/E representative will provide the Contractor with written notice of such defects and shall notify the A/E for advice in the correction of the defects.

8.8 BUILDING OCCUPANCY

The UBO may approve a building or facility being occupied when it is substantially complete. A new building, addition to a building, or a renovated building with a new use group classification shall not be occupied until the UBO issues a form HECO-13.3A. The VT PM shall apply to the UBO for a Certificate of Occupancy by submitting a form HECO-13.3A and a HECO-13.3B, Checklist for Beneficial Occupancy with the required reports and Certificates of Substantial or Final Completion attached. Requests for Partial or Temporary Occupancy shall also include a small-scale floor plan with the subject areas for occupancy noted.

The application shall include the following documents:

1. Form HECO-13.1 or HECO-13.1A
2. Form HECO-13.1B
3. Form HECO-13.2 or HECO-13.2A
4. A copy of the Contractor and A/E's punch lists
5. A letter or report from the regional SFMO stating there are no objections to the building being occupied or stating conditions for occupancy of the building
6. Form HECO-13.3B.

If the A/E's construction visits/inspections were limited, also include a HECO-13.1C (Certificate of Partial or Substantial Completion by Construction Inspector, Project Manager, or Construction Administrator). Projects which have elevators, food service/kitchen facilities, and/or water or wastewater treatment facilities are

required to be inspected separately and have a certificate of compliance issued by the inspecting entity. Include copies of certificates with the Application for Certificate of Use and Occupancy. The UBO may issue a Certificate of Use and Occupancy when the building is substantially complete and all life and fire safety elements of the project design are functioning properly.

8.8.1 Non-Capital Procedures Prior to Occupancy

The UBO shall assure that all inspections and tests are performed and that the work performed conforms to the requirements of the applicable codes and standards and that the building is safe and ready for occupancy.

1. The Contractor shall complete form HECO-13.2 or 13.2A.
2. The A/E (or VT PM/CFR) shall complete a form HECO-13.1 or 13.1A, and a form HECO-13.3B, and submit them to the UBO.
3. The VT PM shall procure other documentation as applicable, such as the potable water report, lightning protection certificate, elevator inspection certificate, testing and balance report, and medical gas certification, and submit them to the UBO.
4. If the project is a new building, or an addition to or renovation of an existing building, the SFMO shall inspect and provide a report recommending acceptance for occupancy.
5. On new buildings, on building additions, or on renovations that involve a change in (use) Group classification, the VT PM shall submit the above documents to the UBO along with form HECO-13.3A.

8.8.2 Issuance of Certificate of Use and Occupancy

The Non-Capital Construction Project Work shall be inspected by the UBO for conformance with the VUSBC as shown on the approved plans and specifications. The VT PM shall submit the forms HECO-13.1A, HECO-13.1B, HECO-13.2A, HECO-13.3B, and other applicable certificates or reports to the UBO, along with the HECO-13.3A when requesting that a Certificate of Use and Occupancy be issued. The UBO may waive some of these requirements based on project size and scope.

Renovation-only projects (not involving an addition to an existing building) or which do not involve a change in use or occupancy for the existing building will not be issued a Certificate of Use and Occupancy. Upon completion, the VT PM shall submit to the UBO forms HECO-13.1, HECO-13.2, HECO-13.3B, and HECO-13.1B in order to close the permit when the construction is completed. The

project is not complete as long as any deficiencies identified by the UBO or the A/E have not been completed, corrected or otherwise resolved.

8.8.3 Temporary Change of Use and Occupancy

Temporary change of use and occupancy requires a Temporary Certificate of Occupancy or issuance of a Special Use Permit by the UBO. The application for Temporary Certificate of Occupancy must be complete, and include an Operational Policy that provides safety measures to address the life safety, health, and welfare of the occupants.

8.9 BENEFICIAL OCCUPANCY – NEW BUILDINGS, ADDITIONS AND RENOVATIONS

Once the VT PM, the A/E, the Contractor, and the SFMO have confirmed in writing that the facility, or a usable portion thereof, is substantially complete and ready for occupancy, the VT PM will submit the HECO-13.3A along with a HECO-13.3B, copies of the HECO-13.1A, HECO-13.1B (if applicable), HECO-13.2A, the SFMO final acceptance report and other required operations permits to the UBO.

The UBO, when satisfied that the project and/or portion of the project is in fact substantially complete in accordance with the contract documents, may issue written authorization (HECO-13.3A) to the VT PM to occupy the project, or applicable portion thereof, subject to any conditions or stipulations stated thereon.

The University shall not occupy the facility until the certification from the SFMO that the project complies with the fire safety requirements and applicable codes and the HECO-13.3A is issued by the UBO. Occupancy of the facility without approval is unlawful and is a misdemeanor (*Code of Virginia* § 36-106, as amended).

The following material is required for consideration of a request for a Temporary or Partial Certificate of Use and Occupancy:

1. Floor plans (small scale) showing areas requested for occupancy and exits/egress routes
2. Type of Occupancy requested: move furniture in for staff, set up/prepare for students, etc.
3. HECO-13.1A with punch list from A/E
4. HECO-13.2A with any attachment from Contractor
5. HECO-13.3B
6. SFMO report and recommendation
7. Document stating that the asbestos abatement, if any, is complete

8. HECO-13.3A with data on entire project and separate sheet showing data on area requested to be occupied.

The University may take Beneficial Occupancy of a portion or unit of the project before completion of the entire project only with the prior written approval of the UBO.

8.10 BENEFICIAL OCCUPANCY – RENOVATIONS WITH NO CHANGE OF USE

For renovations or alterations to existing buildings or portions of buildings which do not constitute a change of use or occupancy classification for the whole building or any part of the building, the VT PM shall prepare and submit form HECO-13.3A. Issuance by the UBO of an approved form HECO-13.3A closes the permit and authorizes re-occupancy of renovated spaces for projects that required the renovation areas to be vacated during construction. If the work has been determined to be substantially complete, but still has work remaining which must be completed under the open permit, the VT PM shall request re-occupancy of the building or specific spaces. The UBO may waive some of these requirements based on project size and scope.

APPENDICES

Appendix A	Campus Design Principles
Appendix B	Student Experience: VT's Next 20 Years
Appendix C	University Space Management
Appendix D	Site Furnishing Guide
Appendix E	Interior Signage Standards Manual
Appendix F	Campus Wayfinding Guidelines
Appendix G	Hokie Stone Masonry Guide Specifications
Appendix H	Transportation & Parking Project Review Checklist